

Dell PowerEdge  
Modular Systems  
**Hardware Owner's  
Manual**



# Notes, Cautions, and Warnings



**NOTE:** A NOTE indicates important information that helps you make better use of your computer.



**CAUTION:** A CAUTION indicates potential damage to hardware or loss of data if instructions are not followed.



**WARNING:** A WARNING indicates a potential for property damage, personal injury, or death.

---

**Information in this publication is subject to change without notice.**

**© 2008–2011 Dell Inc. All rights reserved.**

Reproduction of these materials in any manner whatsoever without the written permission of Dell Inc. is strictly forbidden.

Trademarks used in this text: Dell™, the DELL logo, PowerEdge™, and PowerConnect™ are trademarks of Dell Inc. AMD® and AMD Opteron® are either trademarks or registered trademarks of Advanced Micro Devices, Inc. Intel® and Xeon® are registered trademarks of Intel Corporation in the U.S. and other countries. Microsoft®, MS-DOS®, Windows®, and Windows Server® are registered trademarks of Microsoft Corporation in the United States and/or other countries. Cisco® is a registered trademark of Cisco Systems Inc.

Other trademarks and trade names may be used in this publication to refer to either the entities claiming the marks and names or their products. Dell Inc. disclaims any proprietary interest in trademarks and trade names other than its own.

# Contents

1	About Your System . . . . .	13
	<b>Accessing System Features During Start-up</b> . . . . .	13
	<b>System Overview</b> . . . . .	14
	<b>System Control Panel Features</b> . . . . .	16
	<b>LCD Module</b> . . . . .	18
	LCD Module Features . . . . .	19
	Using the LCD Module Menus . . . . .	19
	<b>Blade Features</b> . . . . .	22
	Using USB Diskette or USB DVD/CD Drives . . . . .	31
	<b>Hard-Drive Features</b> . . . . .	31
	<b>Back-Panel Features</b> . . . . .	34
	Power Supply Indicator . . . . .	36
	Fan Module Indicators . . . . .	37
	<b>Identifying Midplane Version</b> . . . . .	38
	<b>iKVM Module</b> . . . . .	41
	Tiering the Avocent iKVM Switch From an Analog KVM Switch . . . . .	44
	Tiering the Avocent iKVM Switch From a Digital KVM Switch . . . . .	46
	<b>CMC Module</b> . . . . .	48
	<b>I/O Connectivity</b> . . . . .	52

Guidelines for Installing I/O Modules. . . . .	52
Port Auto-Disablement in Quad-Port Network Daughter Card (PowerEdge M710HD Only). . . . .	53
Mezzanine Cards . . . . .	55
I/O Module Port Mapping. . . . .	58
Dell PowerConnect-KR 8024-k Switch . . . . .	69
Dell M8428-k 10 Gb Converged Network Switch. . . . .	71
Mellanox M3601Q QDR Infiniband Switch I/O Module . . . . .	73
Mellanox M2401G Infiniband Switch I/O Module . . . . .	74
Cisco SFS M7000e Infiniband Switch Module . . . . .	75
Cisco Ethernet Switch . . . . .	77
PowerConnect M6348 1 Gb Ethernet Switch I/O Module . . . . .	79
PowerConnect M8024 10 Gb Ethernet Switch I/O Module . . . . .	81
PowerConnect M6220 Ethernet Switch Module . . . . .	83
Dell 10 GbE KR Pass-Through I/O Module . . . . .	85
Dell 8/4 Gbps Fibre Channel Pass-Through I/O Module . . . . .	86
10 Gb Ethernet Pass-Through Module II . . . . .	88
10 Gb Ethernet Pass-Through I/O Module . . . . .	90
4 Gbps Fibre Channel Pass-Through Module. . . . .	92
Brocade M5424 FC8 I/O Module . . . . .	95
Brocade M4424 SAN I/O Module. . . . .	98
10/100/1000 Mb Ethernet Pass-Through Module . . . . .	101
<b>LCD Status Messages . . . . .</b>	<b>103</b>
Viewing Status Messages . . . . .	103
Removing LCD Status Messages . . . . .	103



<b>System Messages</b> . . . . .	<b>115</b>
Warning Messages. . . . .	134
<b>Diagnostics Messages</b> . . . . .	<b>135</b>
<b>Alert Messages</b> . . . . .	<b>135</b>
<b>2 Using the System Setup Program and UEFI Boot Manager</b> . . . . .	<b>137</b>
<b>Choosing the System Boot Mode</b> . . . . .	<b>137</b>
<b>Entering the System Setup Program.</b> . . . . .	<b>138</b>
Responding to Error Messages. . . . .	138
Using the System Setup Program Navigation Keys. . . . .	138
<b>System Setup Options</b> . . . . .	<b>139</b>
Memory Settings Screen. . . . .	140
Processor Settings Screen. . . . .	141
SATA Settings Screen (PowerEdge M610, M610x). . . . .	143
Boot Settings Screen. . . . .	143
Integrated Devices Screen. . . . .	144
PCI IRQ Assignments Screen. . . . .	146
Serial Communication Screen . . . . .	146
Power Management Screen (PowerEdge M915, M910, M710, M710HD, M610 and M610x Only) . . . . .	147
System Security Screen . . . . .	148
Exit Screen . . . . .	149
<b>Entering the UEFI Boot Manager</b> . . . . .	<b>150</b>
UEFI Boot Manager Screen . . . . .	150
UEFI Boot Settings Screen . . . . .	150
System Utilities Screen . . . . .	151

<b>System and Setup Password Features.</b> . . . . .	<b>151</b>
Using the System Password . . . . .	151
Using the Setup Password . . . . .	153
<b>3 Installing Blade Components.</b> . . . . .	<b>155</b>
<b>Recommended Tools.</b> . . . . .	<b>155</b>
<b>Removing and Installing a Blade</b> . . . . .	<b>155</b>
Removing a Blade. . . . .	155
Installing a Blade . . . . .	158
<b>Removing and Installing a Blade Blank.</b> . . . . .	<b>158</b>
Removing a Blade Blank . . . . .	158
Installing a Blade Blank. . . . .	159
<b>Opening and Closing the Blade</b> . . . . .	<b>159</b>
Opening the Blade . . . . .	159
Closing the Blade . . . . .	161
<b>Inside the System.</b> . . . . .	<b>162</b>
<b>System Memory</b> . . . . .	<b>171</b>
System Memory – PowerEdge M915 . . . . .	171
System Memory – PowerEdge M910 . . . . .	177
System Memory – PowerEdge M905 . . . . .	181
System Memory – PowerEdge M805 . . . . .	184
System Memory – PowerEdge M710 . . . . .	188
System Memory – PowerEdge M710HD . . . . .	194
System Memory – PowerEdge M610/M610x. . . . .	199
System Memory – PowerEdge M605 . . . . .	204
System Memory – PowerEdge M600 . . . . .	210
Installing Memory Modules. . . . .	213
Removing Memory Modules . . . . .	214

<b>Mezzanine Interface Card (PowerEdge M610x Only)</b> . . . . .	<b>215</b>
Removing the Mezzanine Interface Card . . . . .	215
Installing the Mezzanine Interface Card . . . . .	217
<b>I/O Module Mezzanine Cards</b> . . . . .	<b>217</b>
Installing a Mezzanine Card . . . . .	219
Removing a Mezzanine Card . . . . .	222
<b>SD Card</b> . . . . .	<b>223</b>
PowerEdge M905 and M805 . . . . .	223
PowerEdge M915, M910, M710, M710HD, M610, and M610x . . . . .	224
<b>SD vFlash Card (PowerEdge M915, M910, M710, M710HD, M610, and M610x Only)</b> . . . . .	<b>225</b>
<b>RAID Battery</b> . . . . .	<b>226</b>
Removing a RAID Battery . . . . .	226
Installing the RAID Battery . . . . .	231
<b>Integrated NIC Hardware Key</b> . . . . .	<b>232</b>
<b>Internal USB Key (PowerEdge M915, M910, M710, M710HD, M610, and M610x Only)</b> . . . . .	<b>232</b>
<b>Network Daughter Card/LOM Riser Card (PowerEdge M915 and M710HD Only)</b> . . . . .	<b>233</b>
Removing the LOM Riser Card . . . . .	233
Installing the LOM Riser Card . . . . .	234
<b>Expansion Cards and Expansion-Card Riser (PowerEdge M610x Only)</b> . . . . .	<b>235</b>
Expansion Card Installation Guidelines . . . . .	235
Installing an Expansion Card . . . . .	236
Removing an Expansion Card . . . . .	238
<b>Expansion-Card Riser (PowerEdge M610x Only)</b> . . . . .	<b>239</b>

Removing the Expansion-Card Riser . . . . .	239
Installing the Expansion-Card Riser . . . . .	243
<b>Processors . . . . .</b>	<b>243</b>
Processor Installation Guidelines . . . . .	243
Removing a Processor . . . . .	244
Installing a Processor. . . . .	259
FlexMem Bridge (PowerEdge M910 Only) . . . . .	261
HT Bridge Card (PowerEdge M905 Only) . . . . .	262
<b>Blade System Board NVRAM Backup Battery. . . . .</b>	<b>265</b>
<b>Hard Drives. . . . .</b>	<b>267</b>
Hard Drive Installation Guidelines . . . . .	267
Installing a Hard Drive . . . . .	267
Removing a Hard Drive . . . . .	269
Configuring the Boot Drive . . . . .	269
Removing a Hard Drive From a Hard-Drive Carrier . . . . .	269
Installing a Hard Drive in a Hard-Drive Carrier . . . . .	270
<b>Video Controller (PowerEdge M905, M805, M605, and M600 Only) . . . . .</b>	<b>272</b>
<b>Hard-Drive Backplane . . . . .</b>	<b>274</b>
<b>Blade System Board . . . . .</b>	<b>276</b>
Removing the System Board . . . . .	276
Installing the System Board. . . . .	280
<b>Storage Controller Card . . . . .</b>	<b>281</b>
Removing the Storage Controller Board . . . . .	281
Installing the Storage Controller Board . . . . .	282
<b>Midplane Interface Card (PowerEdge M610x) . . . . .</b>	<b>283</b>
Removing the Midplane Interface Card . . . . .	283

Installing the Midplane Interface Card . . . . .	285
<b>4 Installing Enclosure Components . . . . .</b>	<b>287</b>
<b>Power Supply Modules . . . . .</b>	<b>287</b>
System Power Guidelines . . . . .	287
Power Supply Blanks . . . . .	288
Removing a Power Supply Module. . . . .	288
Installing a Power Supply Module . . . . .	291
<b>Fan Modules . . . . .</b>	<b>291</b>
Removing a Fan Module . . . . .	291
Installing a Fan Module. . . . .	292
<b>CMC Module . . . . .</b>	<b>293</b>
Removing a CMC Module. . . . .	293
Installing an SD Card in the CMC Module . . . . .	294
Installing a CMC Module . . . . .	295
<b>iKVM Module . . . . .</b>	<b>296</b>
Removing an iKVM Module. . . . .	296
Installing an iKVM Module . . . . .	296
<b>I/O Modules . . . . .</b>	<b>296</b>
Removing an I/O Module . . . . .	296
Installing an I/O Module . . . . .	298
<b>Enclosure Bezel . . . . .</b>	<b>298</b>
Removing the Enclosure Bezel . . . . .	298
Installing the Enclosure Bezel . . . . .	299
<b>Enclosure Midplane . . . . .</b>	<b>300</b>
Installing the Midplane and Front Module Cage Assembly . . . . .	302
<b>Enclosure Control Panel Assembly . . . . .</b>	<b>303</b>

Removing the Enclosure Control Panel . . . . .	303
Installing the Enclosure Control Panel . . . . .	305
<b>LCD Module . . . . .</b>	<b>305</b>
Removing the LCD Module . . . . .	305
Installing the LCD Module . . . . .	307
<b>5 Troubleshooting Your System . . . . .</b>	<b>309</b>
<b>Safety First—For You and Your System . . . . .</b>	<b>309</b>
<b>Start-Up Routine . . . . .</b>	<b>309</b>
<b>Checking the Equipment . . . . .</b>	<b>310</b>
<b>Troubleshooting External Connections . . . . .</b>	<b>310</b>
Troubleshooting Video . . . . .	310
Troubleshooting the Keyboard . . . . .	311
Troubleshooting the Mouse . . . . .	311
Troubleshooting USB Devices . . . . .	312
<b>Responding to a Systems Management Alert Message . . . . .</b>	<b>312</b>
<b>Troubleshooting a Wet Enclosure . . . . .</b>	<b>312</b>
<b>Troubleshooting a Damaged Enclosure . . . . .</b>	<b>313</b>
<b>Troubleshooting Enclosure Components . . . . .</b>	<b>314</b>
Troubleshooting Power Supply Modules . . . . .	314
Troubleshooting Fan Modules . . . . .	315
Troubleshooting the CMC Module . . . . .	315
Troubleshooting the iKVM Module . . . . .	317
Troubleshooting a Network Switch Module . . . . .	318
<b>Troubleshooting Blade Components . . . . .</b>	<b>319</b>

Troubleshooting Blade Memory . . . . .	319
Troubleshooting Hard Drives . . . . .	320
Troubleshooting Expansion Cards . . . . .	321
Troubleshooting Processors . . . . .	322
Troubleshooting the Blade Board . . . . .	323
Troubleshooting the NVRAM Backup Battery . . . . .	324
<b>6 Running System Diagnostics . . . . .</b>	<b>325</b>
<b>Dell PowerEdge Diagnostics . . . . .</b>	<b>325</b>
<b>System Diagnostics Features . . . . .</b>	<b>325</b>
<b>When to Use the System Diagnostics . . . . .</b>	<b>326</b>
<b>Running the System Diagnostics . . . . .</b>	<b>326</b>
Running the Embedded System Diagnostics . . . . .	326
From a USB Flash Drive. . . . .	327
<b>System Diagnostics Testing Options . . . . .</b>	<b>328</b>
<b>Using the Advanced Testing Options . . . . .</b>	<b>329</b>
<b>Error Messages . . . . .</b>	<b>329</b>
<b>7 System Board Information . . . . .</b>	<b>331</b>
<b>Blade System Board Jumper Settings. . . . .</b>	<b>331</b>
PowerEdge M915 Jumper Settings. . . . .	331
PowerEdge M905 Jumper Settings. . . . .	332
PowerEdge M910 Jumper Settings. . . . .	332
PowerEdge M805 Jumper Settings. . . . .	333
PowerEdge M710 Jumper Settings. . . . .	334
PowerEdge M710HD Jumper Settings. . . . .	335

PowerEdge M610/M610x Jumper Settings . . . . .	336
PowerEdge M600 Jumper Settings. . . . .	337
<b>System Board Connectors . . . . .</b>	<b>338</b>
PowerEdge M915 System Board . . . . .	338
PowerEdge M910 System Board . . . . .	340
PowerEdge M905 System Board . . . . .	342
PowerEdge M805 System Board . . . . .	344
PowerEdge M710 System Board . . . . .	346
PowerEdge M710HD System Board . . . . .	348
PowerEdge M610 System Board . . . . .	349
PowerEdge M610x System Board . . . . .	350
PowerEdge M610x Midplane Interface Card. . . . .	352
PowerEdge M610x Expansion-Card Riser . . . . .	353
PowerEdge M610x Mezzanine Interface Card. . . . .	354
PowerEdge M605 System Board . . . . .	355
PowerEdge M600 System Board . . . . .	357
<b>Disabling a Forgotten Password. . . . .</b>	<b>358</b>
<b>8 Getting Help . . . . .</b>	<b>361</b>
<b>    Contacting Dell. . . . .</b>	<b>361</b>
<b>Index . . . . .</b>	<b>363</b>



# About Your System

## Accessing System Features During Start-up

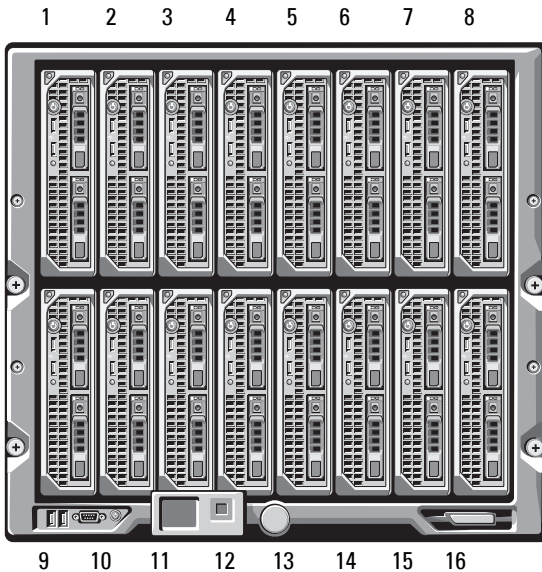
Keystroke	Description
<F2>	Enters the System Setup program. See "Using the System Setup Program and UEFI Boot Manager" on page 137.
<F10>	Enters System Services, which opens the Dell Unified Server Configurator (USC). The Dell USC allows you to access utilities such as embedded system diagnostics. For more information, see the Unified Server Configurator documentation. <b>NOTE:</b> Unified Server Configurator is supported on PowerEdge M610, M610x, M710, M710HD, M910, and M915.
<F11>	Boot Mode set to BIOS: Enters the BIOS Boot Manager, which allows you to select a boot device. Boot Mode set to UEFI: Enters the UEFI Boot Manager, which enables you to manage your system's boot options.
<F12>	Enters PXE boot (if enabled in System Setup program).
<Ctrl><E>	Enters the remote access utility, which allows access to the system event log (SEL) and configuration of remote access to the system.
<Ctrl><C>	Enters the SAS Configuration Utility. See your SAS adapter documentation for more information.
<Ctrl><R>	Enters the RAID configuration utility. For more information, see the documentation for your RAID card.
<Ctrl><S>	Enters the utility to configure NIC settings for PXE boot. For more information, see the documentation for your integrated NIC.

# System Overview

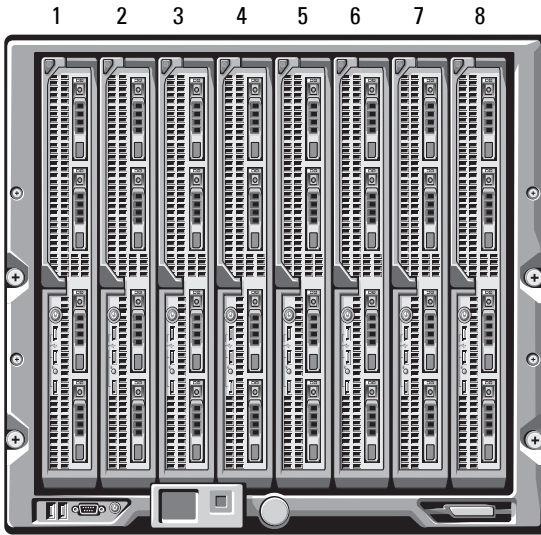
Your system can include up to 16 half-height blades (server modules), eight full-height blades, or a combination of the two blade types (see Figure 1-1, Figure 1-2, and Figure 1-3). To function as a system, a blade is inserted into an enclosure (chassis) that supports power supplies, fan modules, a Chassis Management Controller (CMC) module, and at least one I/O module for external network connectivity. The power supplies, fans, CMC, optional iKVM module, and I/O modules are shared resources of the blades in the PowerEdge M1000e enclosure.

**NOTE:** To ensure proper operation and cooling, all bays in the enclosure must be populated at all times with either a module or with a blank.

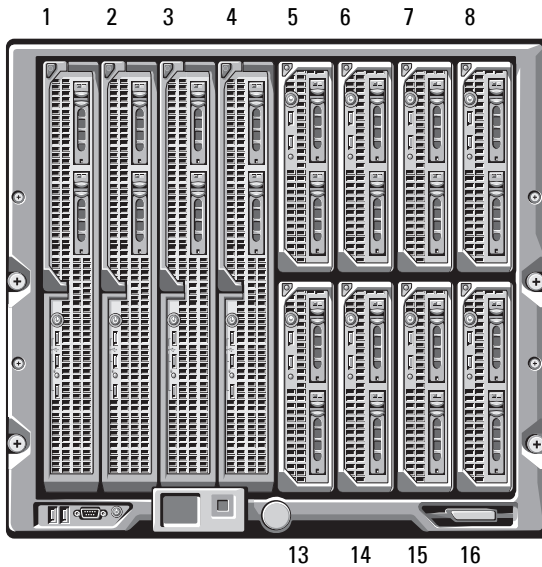
**Figure 1-1. Blade Numbering – Half-Height Blades**



**Figure 1-2. Blade Numbering – Full Height Blades**

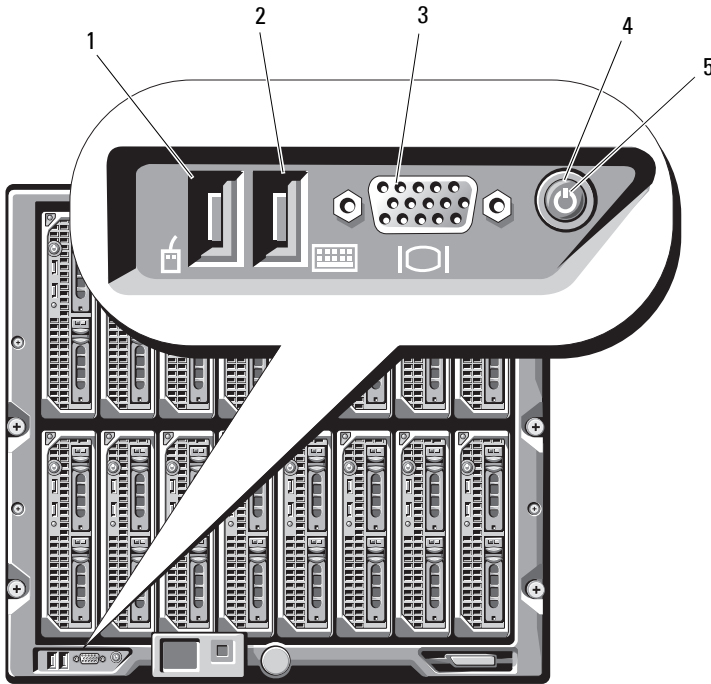


**Figure 1-3. Blade Numbering – Mixed Full-Height and Half-Height Blades**






# System Control Panel Features

Figure 1-4. Control Panel Features



- |   |                       |   |                          |
|---|-----------------------|---|--------------------------|
| 1 | USB port (mouse only) | 2 | USB port (keyboard only) |
| 3 | video connector       | 4 | system power button      |
| 5 | power indicator       |   |                          |

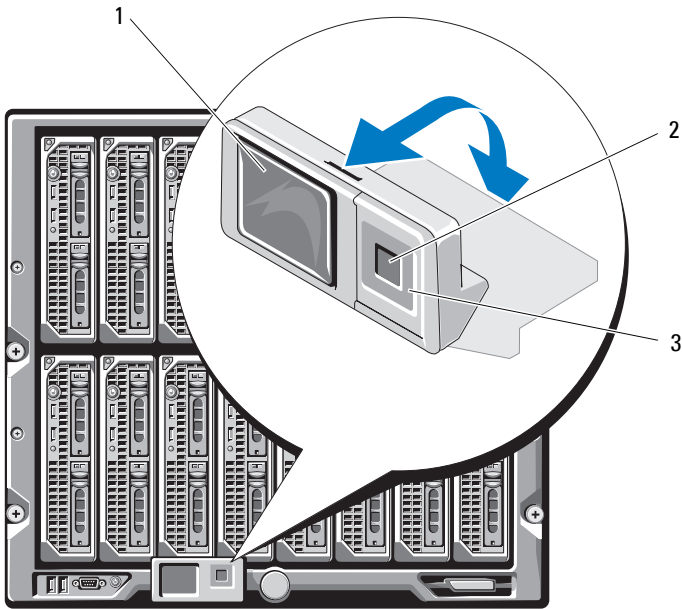
**Table 1-1. Control Panel Features**

<b>Item</b>	<b>Indicator, Button, or Connector</b>	<b>Icon</b>	<b>Description</b>
System power button	N/A		Turns the system on and off. Press to turn on the system. Press and hold 10 seconds to turn off the system.  <b>NOTE:</b> The system power button controls power to all of the blades and I/O modules in the enclosure.
System power indicator	Off Green		Enclosure does not have power. System power is on.
USB ports for keyboard and mouse	N/A		Functional if an optional iKVM module is installed and front panel ports are enabled (default setting) in the CMC interface.  <b>NOTE:</b> These ports do not support USB storage devices. Only connect USB storage devices to the USB ports on the front panel of the blade.
Video connector	N/A		Functional if an optional iKVM module is installed and front panel ports are enabled (default setting) in the CMC interface.

# LCD Module

The LCD module provides an initial configuration/deployment wizard, as well as easy access to infrastructure and blade information, and error reporting. See Figure 1-5.

**Figure 1-5. LCD Display**



- 1 LCD screen
- 2 selection ("check") button
- 3 scroll buttons (4)

## LCD Module Features

The primary function of the LCD module is to provide real-time information on the health and status of the modules in the enclosure.

LCD module features include:

- A deployment setup wizard that allows you to configure the CMC module's network settings during initial system set up.
- Menus to configure the iDRAC in each blade.
- Status information screens for each blade.
- Status information screens for the modules installed in the back of the enclosure, including the IO modules, fans, CMC, iKVM, and power supplies.
- A network summary screen listing the IP addresses of all components in the system.
- Real time power consumption statistics, including high and low values, and average power consumption.
- Ambient temperature values.
- AC power information.
- Critical failure alerts and warnings.


## Using the LCD Module Menus

**Table 1-2. LCD Module Screen Navigation Keys**

<b>Keys</b>	<b>Action</b>
Left and right arrows	Move between screens.
Up arrow or down arrow	Move to the previous or next option on a screen.
Center button	Select and save an item and move to the next screen.


## Configuration Wizard


The CMC is preset for DHCP. To use a static IP address, you must toggle the CMC setting from DHCP to a static address by either running the LCD Configuration Wizard, or by using a management station and CLI commands. (For more information, see the *PowerEdge M1000e Configuration Guide* or CMC documentation.)

 **NOTE:** After you run the configuration wizard, this option is no longer available on the LCD menus.

- 1 Choose a language from the options presented in the dialog box.
- 2 Start the configuration wizard.
- 3 Configure the CMC network settings for your network environment:
  - Network speed
  - Duplex mode
  - Network mode (DHCP or static)
  - Static IP address, subnet mask, and gateway values (if static mode was selected)
  - DNS settings
- 4 If desired, configure the iDRAC network settings.

See the *CMC User's Guide* for detailed information about the iDRAC.

 **NOTE:** The configuration wizard automatically configures each blade's iDRAC internal network interface if you do not choose to manually configure the iDRAC settings.

 **NOTE:** You cannot set a static IP address for the iDRAC using the LCD Configuration Wizard. To set a static IP address, use the CMC Web-based interface or RACADM.

- 5 Review the settings on the **Network Summary** screen.
  - If the settings are correct, press the center button to close the configuration wizard and return to the **Main Menu**.
  - If the settings are not correct, use the left arrow key to return to the screen for that setting and correct it.

After you complete the configuration wizard, the CMC is available on your network.



## **Main Menu**

The **Main Menu** options include links to the **LCD Setup Menu**, **Server Menu**, and **Enclosure Menu**.

## **LCD Setup Menu**

You can change the default language and start-up screen for the LCD menu screens using this menu.

## **Server Menu**

From the **Server Menu** dialog box, you can highlight each blade in the enclosure using the arrow keys, and view its status.

- A blade that is powered off or booting is designated by a gray rectangle. An active blade is indicated by a green rectangle. If a blade has errors, this condition is indicated by an amber rectangle.
- To select a blade, highlight it and press the center button. A dialog box displays the iDRAC IP address of the blade and any errors present.

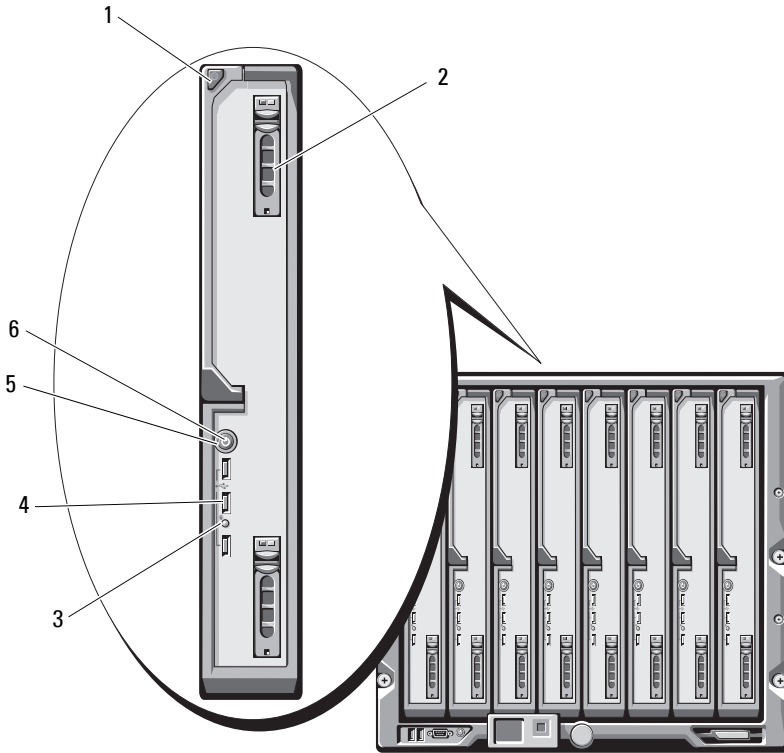
## **Enclosure Menu**

The **Enclosure Menu** includes options for **Module Status**, **Enclosure Status**, and **Network Summary**.

- In the **Module Status** dialog box, you can highlight each component in the enclosure and view its status.
  - A module that is powered off or booting is designated by a gray rectangle. An active module is indicated by a green rectangle. If a module has errors, it is indicated by an amber rectangle.
  - If a module is selected, a dialog box displays the current status of the module and any errors present.
- In the **Enclosure Status** dialog box, you can view the enclosure status, any error conditions, and power consumption statistics.
- The **Network Summary** screen lists the IP addresses for the CMC, the iDRAC in each blade, and other components in the enclosure.

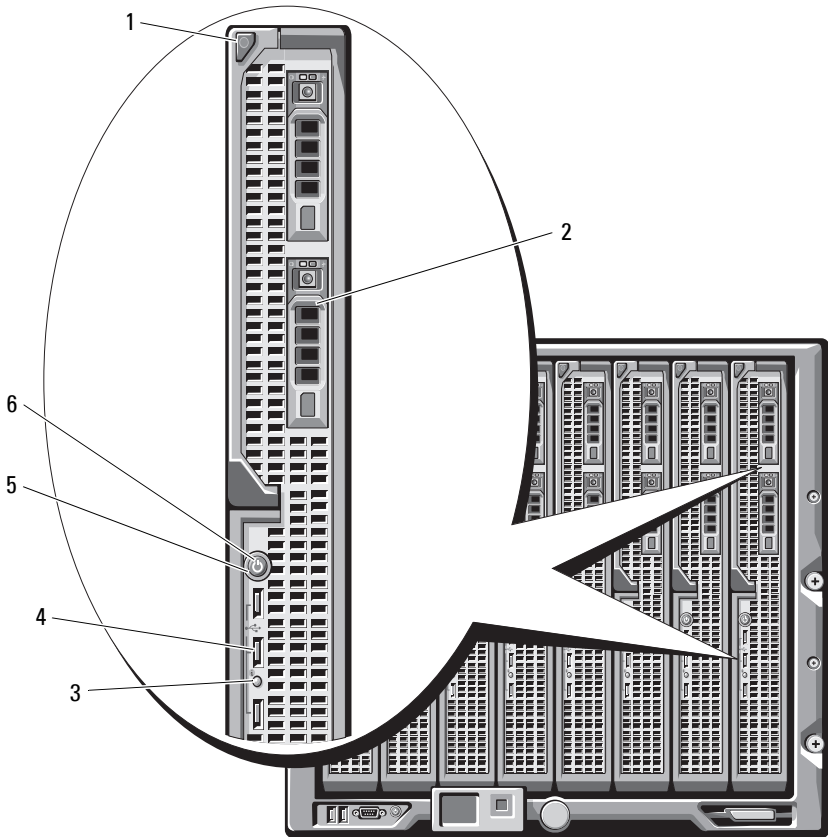
# Blade Features

Figure 1-6. Front Panel Features – PowerEdge M915



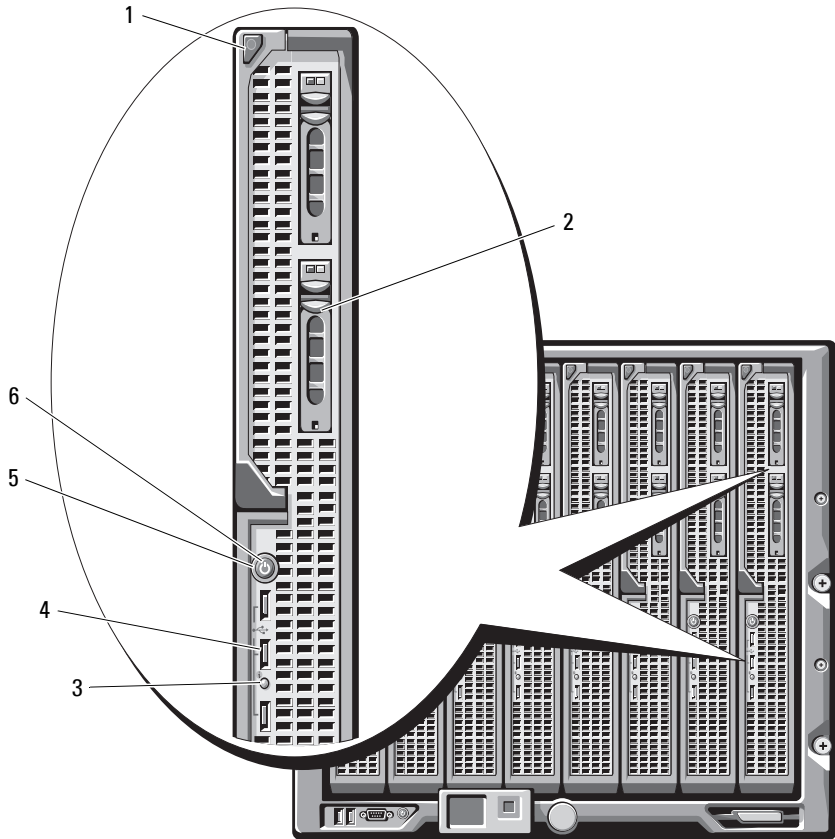
- |   |                                       |   |                       |
|---|---------------------------------------|---|-----------------------|
| 1 | blade handle release button           | 2 | hard drives (2)       |
| 3 | blade status/identification indicator | 4 | USB connectors (3)    |
| 5 | blade power button                    | 6 | blade power indicator |

**Figure 1-7. Front Panel Features – PowerEdge M910**



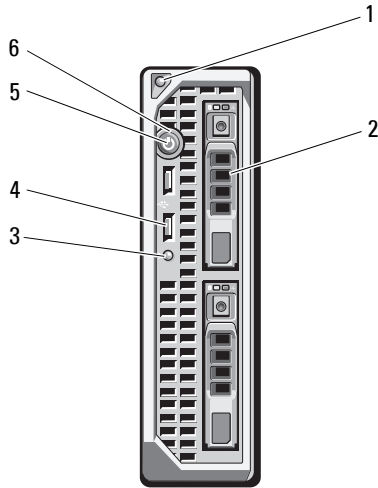
- |   |                                       |   |                       |
|---|---------------------------------------|---|-----------------------|
| 1 | blade handle release button           | 2 | hard drives (2)       |
| 3 | blade status/identification indicator | 4 | USB connectors (3)    |
| 5 | blade power button                    | 6 | blade power indicator |

**Figure 1-8. Front Panel Features – PowerEdge M905 and M805**



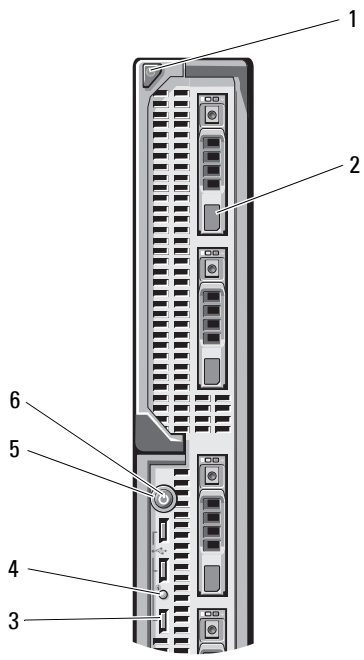
- |   |                                       |   |                       |
|---|---------------------------------------|---|-----------------------|
| 1 | blade handle release button           | 2 | hard drives (2)       |
| 3 | blade status/identification indicator | 4 | USB connectors (3)    |
| 5 | blade power button                    | 6 | blade power indicator |

**Figure 1-9. Front Panel Features – PowerEdge M710HD**



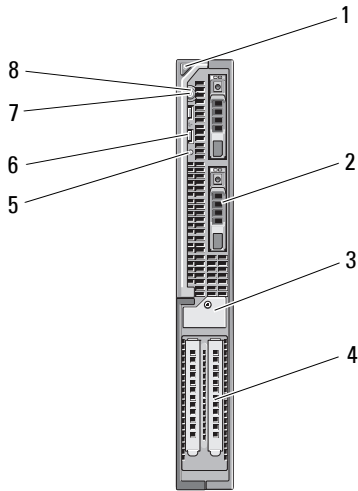
- |   |                                       |   |                       |
|---|---------------------------------------|---|-----------------------|
| 1 | blade handle release button           | 2 | hard drives (2)       |
| 3 | blade status/identification indicator | 4 | USB connectors (2)    |
| 5 | blade power button                    | 6 | blade power indicator |

**Figure 1-10. Front Panel Features – PowerEdge M710**



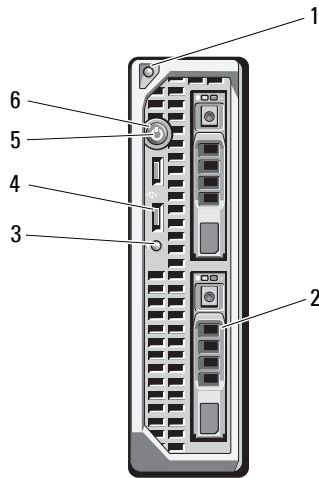
- |   |                             |   |                                       |
|---|-----------------------------|---|---------------------------------------|
| 1 | blade handle release button | 2 | hard drives (4)                       |
| 3 | USB connectors (3)          | 4 | blade status/identification indicator |
| 5 | blade power button          | 6 | blade power indicator                 |

**Figure 1-11. Front Panel Features – PowerEdge M610x**



- |   |  |   |                         |
|---|--|---|-------------------------|
| 1 | blade handle release button                                      | 2 | hard drive (2)          |
| 3 | expansion-card filler-bracket retention latch with captive screw | 4 | expansion-card slot (2) |
| 5 | blade status/identification indicator                            | 6 | USB connector (2)       |
| 7 | blade power button   | 8 | blade power indicator   |

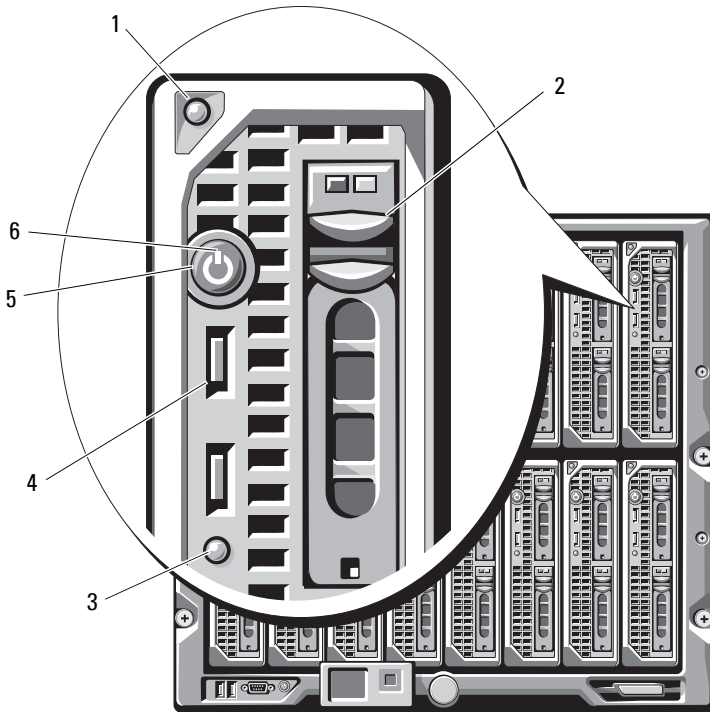
**Figure 1-12. Front Panel Features – PowerEdge M610**



- |   |                                       |   |                       |
|---|---------------------------------------|---|-----------------------|
| 1 | blade handle release button           | 2 | hard drives (2)       |
| 3 | blade status/identification indicator | 4 | USB connectors (2)    |
| 5 | blade power button                    | 6 | blade power indicator |






**Figure 1-13. Front Panel Features – PowerEdge M605 and M600**



- |   |                                       |   |                       |
|---|---------------------------------------|---|-----------------------|
| 1 | blade handle release button           | 2 | hard drives (2)       |
| 3 | blade status/identification indicator | 4 | USB connectors (2)    |
| 5 | blade power button                    | 6 | blade power indicator |

**Table 1-3. Blade Control Panel Features**

Feature	Icon	Description
Blade power indicator		<p>Off – Power is not available to the blade, the blade is in standby mode, the blade is not turned on, or the blade is installed incorrectly. For detailed information on installing a blade, see "Installing a Blade" on page 158.</p> <p>Green increasing from low brightness to full brightness – Blade power on request is pending.</p> <p>Green on – The blade is turned on.</p>
Blade status/identification indicator		<p>Off – The blade power is off.</p> <p>Blue – Normal operating state.</p> <p>Blue blinking – The blade is being remotely identified using the CMC.</p> <p>Amber blinking – Blade has either detected an internal error, or the installed mezzanine card(s) does not match the I/O modules installed in the M1000e enclosure. Check the CMC for an I/O configuration error message and correct the error.</p>
Blade power button	N/A	<p>Turns blade power off and on.</p> <ul style="list-style-type: none"><li>• If you turn off the blade using the power button and the blade is running an ACPI-compliant operating system, the blade can perform an orderly shutdown before the power is turned off.</li><li>• If the blade is not running an ACPI-compliant operating system, power is turned off immediately after the power button is pressed.</li><li>• Press and hold the button to turn off the blade immediately.</li></ul> <p>The blade power button is enabled by default by the System Setup program. (If the power button option is disabled, you can only use the power button to turn on the blade. The blade can then only be shut down using system management software.)</p>
USB connector		Connects external USB 2.0 devices to the blade.

## Using USB Diskette or USB DVD/CD Drives

Each blade has USB ports on the front of the blade which allows you to connect a USB diskette drive, USB flash drive, USB DVD/CD drive, keyboard, or mouse. The USB drives can be used to configure the blade.



**NOTE:** These blades support only Dell-branded USB 2.0 drives. The drive must be horizontal and level to operate properly. Use the optional external drive storage tray to support the drive while in use.



**NOTE:** If the drive must be designated as the boot drive, connect the USB drive, restart the system, then enter the System Setup Program and set the drive as first in the boot sequence (see "Using the System Setup Program and UEFI Boot Manager" on page 137). The USB device is displayed in the boot order setup screen only if it is attached to the system before you run the System Setup program. You can also select the boot device by pressing <F11> during system start-up and selecting a boot device for the current boot sequence.

## Hard-Drive Features

- PowerEdge M915 supports two 2.5-inch SAS or solid-state disk (SSD) hard drives.
- PowerEdge M910 supports up to two 2.5-inch SAS, SATA, or SSD hard drives.
- PowerEdge M905 and M805 support one or two hot-swappable 2.5-inch SAS hard drives.
- PowerEdge M710HD supports up to two hot-swappable 2.5-inch SAS or SSD hard drives.
- PowerEdge M710 supports up to four hot-swappable 2.5-inch SAS hard drives.
- PowerEdge M610, M610x, M600, and M605 support one or two 2.5-inch SATA hard drives or one or two 2.5-inch SAS hard drives.



**NOTE:** SAS and SATA hard drives cannot be mixed within a blade.



**NOTE:** SATA hard drives are not hot swappable with the SATA repeater daughter card.



**NOTE:** Hot-swap drive operation is supported if an optional RAID controller card is installed in the blade.

The hard-disk drives plug into the internal storage backplane inside the blade. On blades with a diskless configuration, all hard drive slots must be filled with hard drive blanks, and the internal storage backplane must still be installed to maintain proper airflow.

See Figure 1-14 for information on the hard-drive indicators. Different patterns are displayed as drive events occur in the system.

**NOTE:** The blade must have a hard drive or a hard-drive blank installed in each hard-drive bay.

**NOTE:** The hard-drive status indicator is only functional for RAID hard drive configurations. For non-RAID configurations, only the drive-activity indicator is active. Refer to the RAID controller documentation to service a RAID volume, rebuild an array, or swap RAID members.

**Figure 1-14. Hard-Drive Indicators**



1 drive-activity indicator (green)

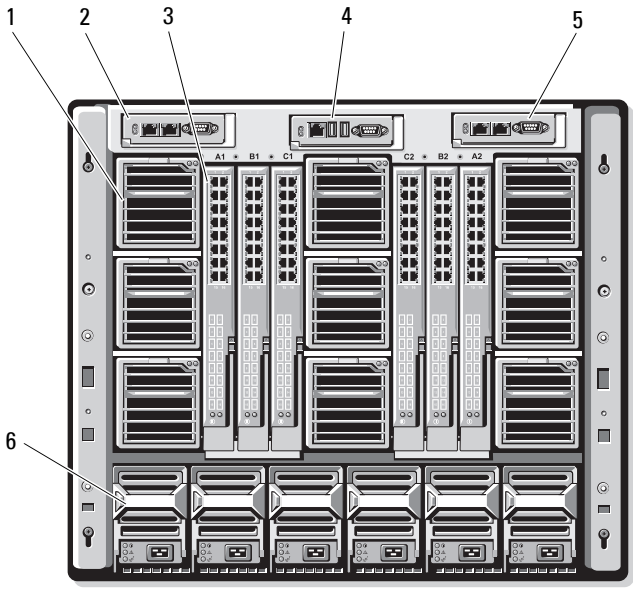
2 drive-status indicator (green and amber)

**Table 1-4. Hard-Drive Indicators**

<b>Condition</b>	<b>Drive-Status Indicator Pattern</b>
Identifying drive/preparing for removal	Blinks green two times per second
Drive ready for insertion or removal	Off <b>NOTE:</b> The drive status indicator remains off until all hard drives are initialized after system power is applied. Drives are not ready for insertion or removal during this time.
Drive predicted failure	Blinks green, amber, and off.
Drive failed	Blinks amber four times per second.
Drive rebuilding	Blinks green slowly.
Drive online	Steady green.
Rebuild halted	Blinks green three seconds, amber three seconds, and off six seconds.

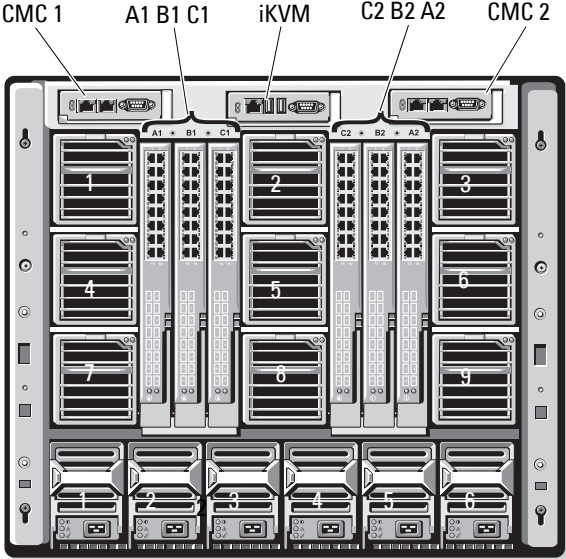
# Back-Panel Features

Figure 1-15. Back-Panel Features




- |   |                      |   |                      |
|---|----------------------|---|----------------------|
| 1 | fan modules (9)      | 2 | primary CMC module   |
| 3 | I/O modules (6)      | 4 | optional iKVM module |
| 5 | secondary CMC module | 6 | power supplies (6)   |

**Figure 1-16. Back-Panel Module Bay Numbering**

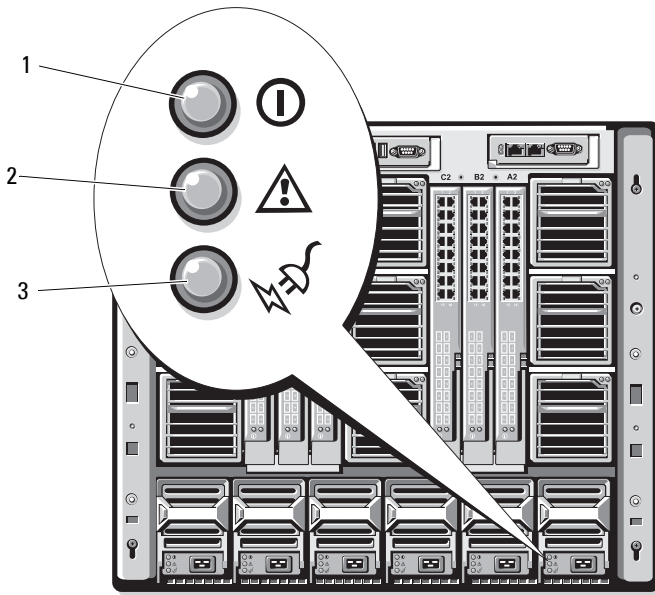


## Power Supply Indicator

 **NOTE:** The power supplies must be connected to a PDU, not directly to an electrical outlet.

- The power supplies require a 200-240 V power source.
- A 2700 W power supply can be connected to a 110 V AC power source.




**Figure 1-17. Power Supply Indicators**



- |   |                            |   |                              |
|---|----------------------------|---|------------------------------|
| 1 | DC power output indicator  | 2 | power supply fault indicator |
| 3 | AC power present indicator |   |                              |

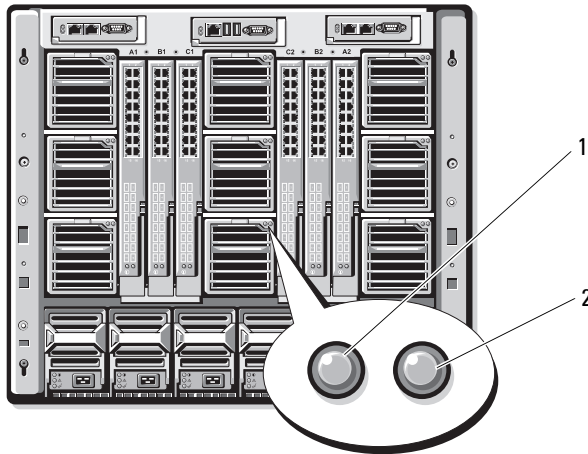


**Table 1-5. Power Supply Indicators**

Indicator	Icon	Description
Power supply status		Green indicates that the power supply is operational and providing DC power to the system.
Fault indicator		Amber indicates a problem with the power supply, which can result from either a failed power supply or a failed fan within the power supply. See "Power Supply Modules."
AC power source present indicator		Green indicates that a valid AC source is connected to the power supply and is operational.

## Fan Module Indicators

**Figure 1-18. Fan Module Indicators**



1 fan power indicator

2 fan fault indicator

**Table 1-6. Fan Indicators**





<b>Indicator</b>	<b>Indicator State</b>	<b>Description</b>
Power indicator	Green	The power supply is connected to an AC power source.
	Off	AC power not connected.
Fault indicator	Amber	The fan is in a fault condition.
	Off	Fan not faulty.

## Identifying Midplane Version

The version of the midplane installed in the enclosure is displayed in the **Midplane Revision** field under the **Summary** tab of the CMC Web-based interface.

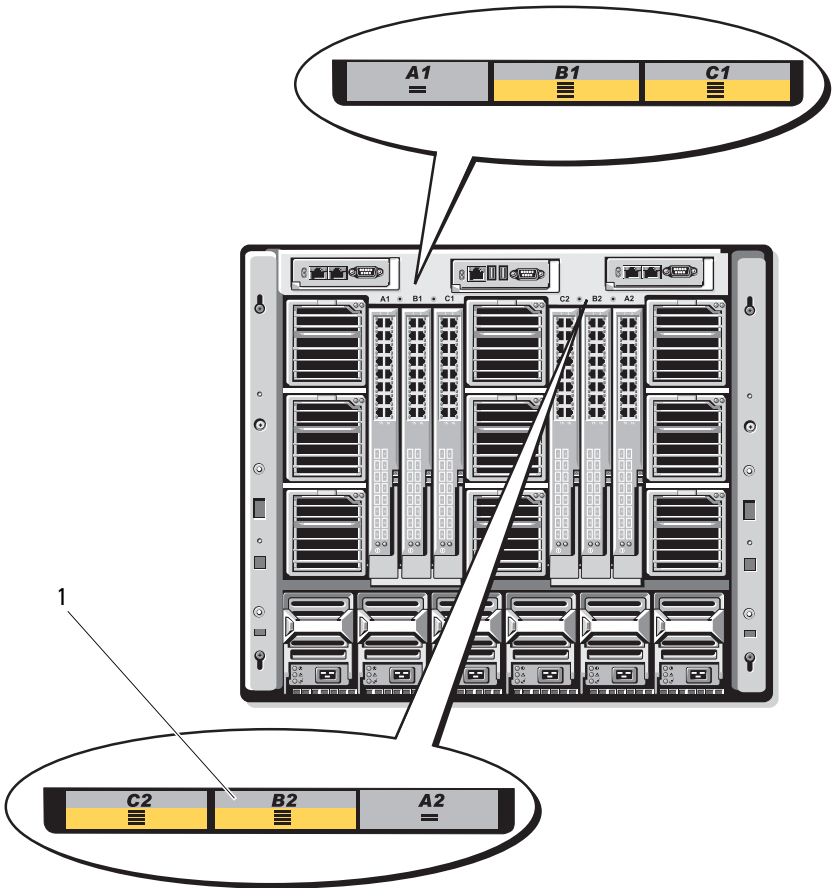
You can also view the icons at the back of the enclosure to identify the version of the midplane installed in the system. Table 1-7 describes the icons at the back of the enclosure.

**Table 1-7. Identifying Midplane Version**

<b>Marking</b>	<b>Description</b>	<b>Midplane Version</b>
	I/O module slots A1, A2	1.1
	I/O module slots B1, B2, C1, and C2	1.1
	I/O module slots A1, A2	1.0
	I/O module slots B1, B2, C1, and C2	1.0

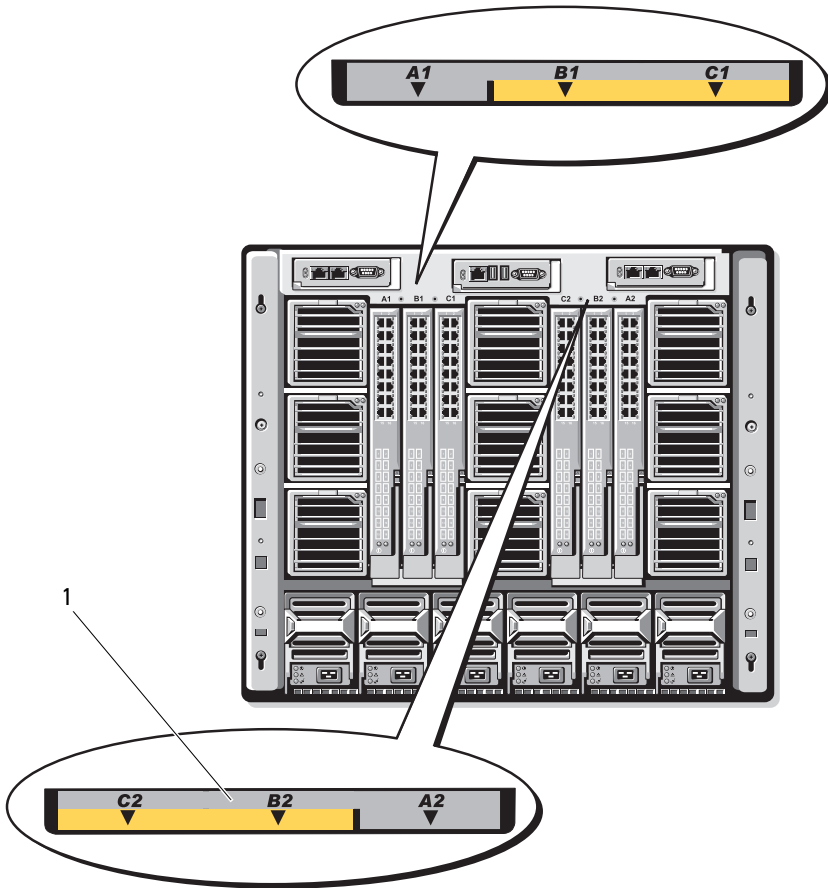
See Figure 1-19 and Figure 1-20 to locate the midplane identification labels on the enclosure.

**Figure 1-19. Identifying Midplane Version 1.1**



1 midplane identification label (2)

**Figure 1-20. Identifying Midplane Version 1.0**



1 midplane identification label (2)

## iKVM Module

The optional Avocent iKVM analogue switch module includes the following features:

- Local iKVM access can be remotely disabled on a per blade basis, using the blade's iDRAC interface (access is enabled by default).



**NOTE:** By default (enabled), a console session to a given blade is available to both the iDRAC interface and iKVM (users connected to a blade's console using iDRAC and the iKVM sees the same video and is able to type commands). If this sharing is not desired, this can be disabled using the iDRAC console interface.

- The following connectors:
  - One VGA connector. The iKVM supports a video display resolution range from 640×480 at 60 Hz up to 1280×1024×65,000 colors (noninterlaced) at 75 Hz.
  - Two USB ports for keyboard and mouse.



**NOTE:** The iKVM USB ports do not support storage devices.

- RJ-45 ACI port for tiering with Dell and Avocent analog KVM and KVM over IP switches with ARI ports.



**NOTE:** Although the ACI port is an RJ-45 connector and uses Cat5 (or better) cabling, it is not an Ethernet network interface port. It is only used for connection to external KVM switches with Analog Rack Interface (ARI) ports, and does not support native KVM over IP.

- The iKVM can also be accessed from the front of the enclosure, providing front or back panel KVM functionality, but not at the same time. For enhanced security, front panel access can be disabled using the CMC's interface.

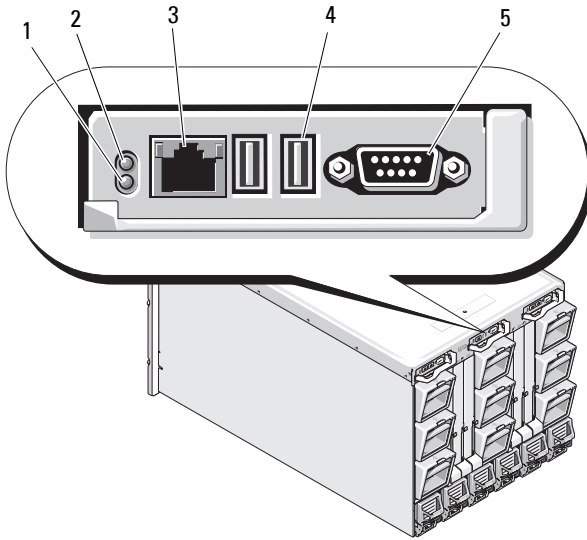


**NOTE:** Connecting a keyboard, video, and mouse to the enclosure front panel disables video output to the iKVM back panel port. It does not interrupt iDRAC video and console redirection.

- You can use the iKVM to access the CMC console directly, using RACADM or using the Web-based interface. For more information, see "Using the iKVM Module" in the CMC *User's Guide*.

Figure 1-21 shows the external features of the iKVM switch module.

**Figure 1-21. Avocent iKVM Switch Module**



- 1 identification indicator
- 2 status indicator
- 3 ACI port for tiering connection only
- 4 USB connectors (2) for keyboard and mouse
- 5 video connector

**CAUTION: Do not connect the ACI port to a LAN device such as a network hub. Doing so may result in equipment damage.**

**Table 1-8. Avocent Analog iKVM Switch Module Features**

Feature	Indicator Pattern	Description
Power indicator	Off	iKVM switch does not have power.
	Green	iKVM switch has power.
	Green flashing	Firmware upgrade in progress
Status/identification indicator	Blue blinking	iKVM module is being identified.
	Amber flashing	System fault or error condition.

**Table 1-8. Avocent Analog iKVM Switch Module Features**

<b>Feature</b>	<b>Indicator Pattern</b>	<b>Description</b>
USB connectors		Allows a keyboard and mouse to be connected to the system.
Video connector		Allows a monitor to be connected to the system.
ACI port		Allows connection of one or more servers to a Dell console switch with an Analog Rack Interface (ARI) port, such as an external digital or analog switch.
Link indicator	Off	The ACI is not connected to the external switch.
	Green	The ACI is connected to the external switch.
Activity indicator	Off	Data is not being sent or received.
	Amber blinking	Data is being sent or received.

## Tiering the Avocent iKVM Switch From an Analog KVM Switch

The Avocent iKVM switch can be tiered from analog KVM switches such as the Dell 2160AS and 180AS, as well as many Avocent analog KVM switches. Many switches may be tiered without the need for a Server Interface Pod (SIP) (see Table 1-9).

**Table 1-9. Cabling Requirements for External Analog KVM Switches**

Switch	Tiering Cabling Requirements
Dell PowerConnect 180AS, 2160AS Avocent Autoview 1400, 1500, 2000, 2020, 2030, Ax000R	Seamless tiering using ACI port and Cat 5 cable
Avocent Autoview 200, 400, 416, 424 Avocent Outlook 140ES, 180ES, 160ES	Dell USB SIP required with Cat 5 cable

Before connecting the iKVM switch to a supported analog switch, you must set the iKVM switch to display in slot order, and set the **Screen Delay Time** to 1 or more seconds:

- 1 Press <Print Screen> to launch the iKVM Switch OSCAR.  
The OSCAR dialog box appears on the monitor connected to the iKVM.
- 2 Click **Setup**→**Menu**. The **Menu** dialog box appears.
- 3 Select **Slot** to display servers numerically by slot number.
- 4 Enter a screen delay time of at least 1 second.
- 5 Click **OK**.

Setting the **Screen Delay Time** to 1 second allows you to soft switch to a server without launching OSCAR.



**NOTE:** Soft switching allows you to switch servers using a hot key sequence. You can soft switch to a server by pressing <Print Screen> and then typing the first few characters of its name or number. If you have a Delay Time set and you press the key sequences before that time has elapsed, OSCAR does not display.



To configure the analog switch:

- 1 Press <Print Screen> to open the OSCAR **Main** dialog box.
- 2 Click **Setup**→**Devices**→**Device Modify**.
- 3 Select the 16-port option to match the number of blades in your system.
- 4 Click **OK** to exit OSCAR.
- 5 Press <Print Screen> to verify that the settings have taken effect. The slot number of the blade to which the iKVM switch is now attached should be expanded to display each of the slot locations of the blades in the system. For instance, if the iKVM switch is attached to slot 1, it would now be displayed as 01-01 to 01-16.

To connect the Avocent iKVM switch to a supported analog switch:

- 1 *If the switch does not require a SIP to connect to the iKVM (see Table 1-9), connect a Cat5 (or newer) cable to the RJ-45 ACI port on the iKVM module. See Figure 1-21.*

Connect the other end of this cable to the ARI port on the external switch.

*If the analog switch requires a USB SIP (see Table 1-9), connect a USB SIP to the iKVM, then connect a Cat5 (or newer) cable to the SIP. Connect the other end of this cable to the ARI port on the external switch.*

- 2 Connect both the analog switch and the system to an appropriate power source.
- 3 Turn on the system.
- 4 Turn on the external analog switch.



**NOTE:** If the external analog switch is turned on before the system, it may result in only one blade displaying in the analog switch OSCAR, instead of 16. If this behavior occurs, shut down and restart the switch so that the entire complement of blades is recognized.



**NOTE:** In addition to the steps outlined above, some external analog switches may require you to perform additional steps to ensure that the iKVM switch blades appear in the external analog switch OSCAR. See the external analog switch documentation for more information.

## Tiering the Avocent iKVM Switch From a Digital KVM Switch

The iKVM switch may also be tiered from a digital KVM switch such as the Dell 2161DS or 4161DS, or a supported Avocent digital KVM switch. Many switches may be tiered without the need for a SIP (see Table 1-10).

**Table 1-10. Cabling Requirements for External Digital KVM Switches**

Switch	Tiering Requirements
Dell PowerConnect 2161DS, 4161DS	Seamless tiering using ACI port and Cat 5 cable
Avocent DSR 800, x16x, x010, x031, x030, x035, 102x (except 1024)	
Avocent DSR 1024	Dell USB SIP required with Cat 5 cable

To tier the iKVM switch module from a Dell 2161DS, 180AS, or 2160AS console switch:

- *If the switch does not require a SIP to connect to the iKVM (see Table 1-10), connect a Cat5 (or newer) cable to the RJ-45 ACI port on the iKVM module. See Figure 1-21.*

Connect the other end of this cable to the ARI port on the external switch.

- *If the switch requires a USB SIP (see Table 1-9), connect a USB SIP to the iKVM, then connect a Cat5 (or newer) cable to the SIP. Connect the other end of this cable to the ARI port on the external switch.*

Once the KVM switch is connected, the server modules appear in OSCAR.



**NOTE:** Once the local system is set up, you must also resynchronize the server list from the Remote Console Switch software in order to see the list of blades. See *Resynchronizing the Server List at the Remote Client Workstation.*

## Resynchronizing the Server List at the Remote Client Workstation

Once the iKVM switch is connected, the blades appear in OSCAR. You now need to resynchronize the servers on any remote workstation to ensure that the blades are available to any remote users connected to the console switch through the Remote Console Switch software.



**NOTE:** This procedure only resynchronizes one remote client workstation. With multiple client workstations, save the resynchronized local database and load it into the other client workstations to ensure consistency.

To resynchronize the server listing:

- 1 Click **Resync** in the **Server** category of the Management Panel (MP).  
The Resync Wizard launches.

- 2 Click **Next**.

A warning message displays indicating that the database is updated to match the current configuration of the console switch. Your current local database names may be overridden with the switch names. To include unpowered SIPs in the resynchronization, click to enable the **Include Offline SIPs** check-box.

- 3 Click **Next**.

A **Polling Remote Console Switch** message box appears with a progress bar indicating that the switch information is being retrieved.

- 4 If no changes were detected in the appliance, a completion dialog box appears with this information.

If server changes were detected, then the **Detected Changes** dialog box is displayed. Click **Next** to update the database.

- 5 If a cascade switch was detected, the **Enter Cascade Switch Information** dialog box appears. Select the type of switch connected to the appliance from the drop-down list. If the type you are looking for is not available, you can add it by clicking **Add**.

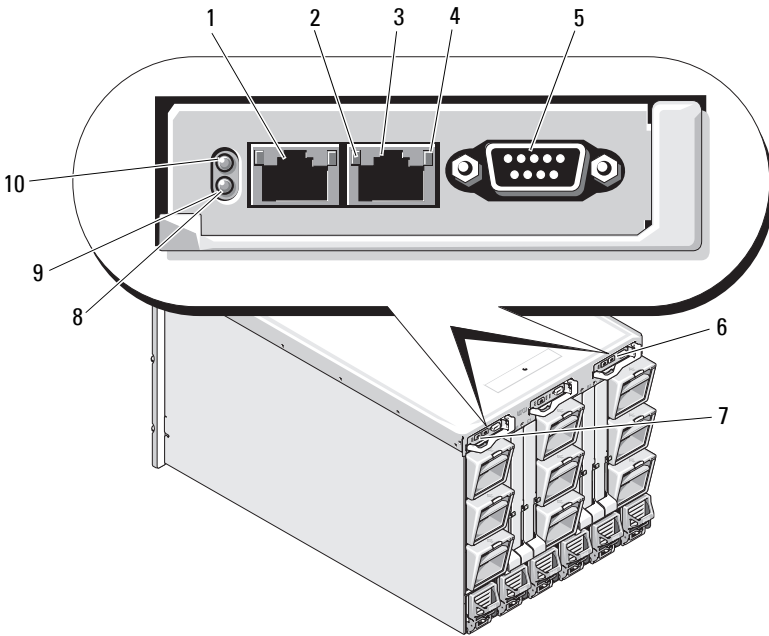
- 6 Click **Next**. The completion dialog box appears.

- 7 Click **Finish** to exit.

- 8 Start up the analog switch and the system.

# CMC Module

Figure 1-22. CMC Module Features



- |   |  |    |                                |
|---|--|----|--------------------------------|
| 1 | Ethernet connector Gb1   | 2  | link indicator (2)             |
| 3 | Ethernet connector STK ("stack") - used for daisy-chaining CMCs in separate enclosures | 4  | activity indicator (2)         |
| 5 | DB-9 serial connector for local configuration  | 6  | optional secondary CMC (CMC 2) |
| 7 | primary CMC (CMC 1)  | 8  | amber fault indicator          |
| 9 | blue status/identification indicator   | 10 | power indicator                |

**Table 1-11. CMC Module Features**


<b>Indicator</b>	<b>Pattern</b>	<b>Description</b>
Network interface controller link indicator	Off	LAN is not linked.
	Green	LAN is linked.
Network interface controller activity indicator	Off	LAN is not active.
	Amber blinking	Indicates that the system CMC and the LAN are communicating.
Power indicator	Off	CMC does not have power.
	Green	CMC has power.
	Green blinking	Firmware update in progress.
Status/identification indicator	Off	This CMC is the standby CMC.
	Blue (solid)	This CMC is the primary CMC.
	Blue (blinking)	The CMC is being identified by the systems management software.
Fault indicator	Off	The CMC is operating normally.
	Amber blinking	A fault has occurred.
Serial connector	None	Used for local configuration (115200 baud, No parity, 8, 1)

The CMC provides multiple systems management functions for your modular server:

- Enclosure-level real-time automatic power and thermal management.
  - The CMC monitors system power requirements and supports the optional Dynamic Power Supply Engagement mode so that the CMC can enable or place power supplies in standby dynamically depending on load and redundancy requirements to improve power efficiency.
  - The CMC reports real-time power consumption, which includes logging high and low points with a time stamp.

- The CMC supports setting an optional enclosure Maximum Power Limit, which either alerts or takes actions, such as throttling server modules and/or preventing the power up of new blades to keep the enclosure under the defined maximum power limit.
- The CMC monitors and automatically controls cooling fans based on actual ambient and internal temperature measurements.
- The CMC provides comprehensive enclosure inventory and status/error reporting.
- The CMC provides a mechanism for centralized configuration of the following:
  - The M1000e enclosure's network and security settings
  - Power redundancy and power ceiling settings
  - I/O switches and iDRAC network settings
  - First boot device on the server blades
  - The CMC checks I/O fabric consistency between the I/O modules and blades and disables components if necessary to protect the system hardware.
  - User access security.

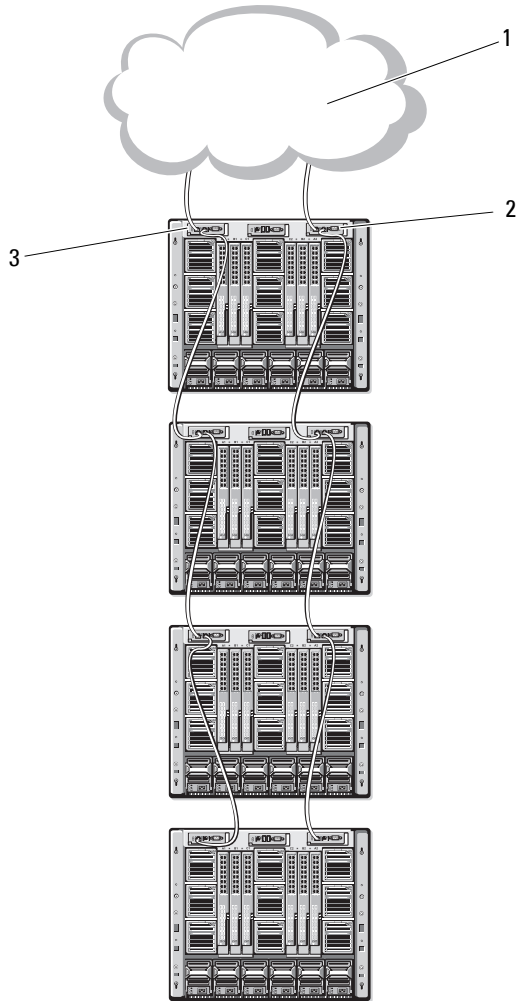
The CMC has two Ethernet ports: Gb1 is used to connect to the external management network. The connector labeled STK ("stack") allows CMCs in adjacent enclosures to be daisy-chained. A 24-port Ethernet switch provides internal communication between the iDRAC on each blade, I/O modules, optional KVM, and optional second, redundant CMC.

 **NOTE:** The 24-port Ethernet switch is reserved for internal communication between the iDRAC on the blades to the CMC and the external management network. If two CMCs are installed, the heartbeat for CMC redundancy is also present and CMC redundancy is supported over this internal network. This internal network is outside the data path from host LOMs and the mezzanine cards in the blades.

At least one CMC must be installed in the primary CMC bay (see Figure 1-22) for the system to power up. If a second, optional CMC module is installed, failover protection and hot-plug replacement is available.

See the latest *Dell Chassis Management Controller User's Guide* at [support.dell.com/manuals](http://support.dell.com/manuals) for complete instructions on how to set up and operate the CMC module.

**Figure 1-23. CMC Daisy-Chaining**



- 1 management network
- 3 primary CMC

- 2 secondary CMC

# I/O Connectivity

The M1000e enclosure supports three layers of I/O fabric, selectable between combinations of Ethernet, fibre-channel, and Infiniband modules. You can install up to six hot-swappable I/O modules in the enclosure, including fibre-channel switches, fibre-channel pass-throughs, Infiniband switches, Ethernet switches, and Ethernet pass-through modules.

## Guidelines for Installing I/O Modules

You must follow these guidelines when populating I/O modules. See Figure 1-15 for the I/O bay locations.

### General I/O Module Configuration Guidelines

- If an I/O module is installed in Fabric B or Fabric C, at least one blade must have a matching mezzanine card installed to support data flow for that I/O module.
- If a blade has an optional mezzanine card installed in a Fabric B or Fabric C card slot, at least one corresponding I/O module must be installed to support data flow for that fabric.
- Modules may be installed in Fabrics B and C independently (you do not need to install modules in Fabric B before installing modules in the Fabric C slots.)
- Slots A1 and A2 only support Ethernet I/O modules. This fabric type is hard-set to Ethernet for these slots and cannot support Fibre Channel, Infiniband, or other fabric type modules.
- Fabrics A, B, and C can support Ethernet fabric-type modules.
- To enable switch configuration prior to blade imaging, I/O modules are allowed to power-up before a blade is inserted in the enclosure.

### Fabric A

Fabric A is a redundant Gb Ethernet fabric, supporting I/O module slots A1 and A2. The integrated Ethernet controllers in each blade dictate Fabric A as an Ethernet-only fabric.



**NOTE:** Fabric A supports KR (10 Gbps standard) if the midplane version in the enclosure is 1.1 or later. To identify the midplane version, see "Identifying Midplane Version" on page 38.





**NOTE:** Modules designed specifically for Fabric B or Fabric C cannot be installed in slots A1 or A2, as indicated by the color-coded labeling on the faceplate of each module.

## Fabric B

Fabric B is a 1 to 40 Gb/sec redundant fabric, supporting I/O module slots B1 and B2. Fabric B currently supports 1 Gb or 10 Gb Ethernet, DDR/QDR Infiniband, and 4 Gbps or 8 Gbps Fibre Channel modules. Additional fabric types may be supported in the future.



**NOTE:** If the midplane version in the enclosure is 1.1 or later, Fabric B supports up to 16 Gbps Fibre Channel, Infiniband FDR (14 Gbps standard), and KR (10 Gbps standard). To identify the midplane version, see "Identifying Midplane Version" on page 38.

To communicate with an I/O module in the Fabric B slots, a blade must have a matching mezzanine card installed in a Fabric B mezzanine card location.

Modules designed for Fabric A may also be installed in the Fabric B slots.

## Fabric C

Fabric C is a 1 to 40 Gb/sec redundant fabric, supporting I/O module slots C1 and C2. Fabric C currently supports 1 Gb or 10 Gb Ethernet, DDR/QDR Infiniband, and 4 Gbps or 8 Gbps Fibre Channel modules. Additional fabric types may be supported in the future.



**NOTE:** If the midplane version in the enclosure is 1.1 or later, Fabric C supports up to 16 Gbps Fibre Channel, Infiniband FDR (14 Gbps standard), and KR (10 Gbps standard). To identify the midplane version, see "Identifying Midplane Version" on page 38.


To communicate with an I/O module in the Fabric C slots, a blade must have a matching mezzanine card installed in a Fabric C mezzanine card location.

Modules designed for Fabric A may also be installed in the Fabric C slots.

## Port Auto-Disablement in Quad-Port Network Daughter Card (PowerEdge M710HD Only)

Systems installed with quad-port Network Daughter Card support Port Auto-Disablement feature. This feature disables the third (NIC3) and fourth (NIC4) ports of a quad-port Network Daughter Card during system boot, if the corresponding IO module installed in the chassis Fabric A slots do not

support quad-port mapping. This behavior is limited to Fabric A slots only and is automatically enabled or disabled depending on the type of IO module installed.

 **NOTE:** A quad-port Network Daughter Card must be used with a 48-port switch module (32 internal ports) for all the ports to be active.


 **NOTE:** LOM firmware updates are applied only to the enabled ports on a quad-port network daughter card.

Table 1-12 provides an overview of the configurations that enable/disable the NIC3 and NIC4 ports of a quad-port Network Daughter Card.

**Table 1-12. Port Auto-Disablement Decision Table**

<b>IOM Slot A1</b>	<b>IOM Slot A2</b>	<b>NIC3 and NIC4 (Enabled/Disabled)</b>	<b>Port Auto-Disablement</b>
Empty	Empty	Enabled	Inactive
Empty	Dual Port	Disabled	Active
Empty	Quad or Greater Port	Enabled	Inactive
Dual Port	Empty	Disabled	Active
Dual Port	Dual Port	Disabled	Active
Dual Port	Quad or Greater Port	Enabled	Inactive
Quad or Greater Port	Empty	Enabled	Inactive
Quad or Greater Port	Dual Port	Enabled	Inactive
Quad or Greater Port	Quad or Greater Port	Enabled	Inactive

## Mezzanine Cards

### PowerEdge M610x Only

PowerEdge M610x supports two mezzanine cards. Mezzanine cards can be installed in both the slots on the midplane interface card.



**NOTE:** PowerEdge M610x is a full-height blade but supports only two mezzanine cards in the expansion bay. The two mezzanine slots on the M610x system board (MEZZ2\_FAB\_B and MEZZ1\_FAB\_C) are reserved for the mezzanine interface card. See "Mezzanine Interface Card (PowerEdge M610x Only)" on page 215.

### Full-Height Blades

Full-height blades support four mezzanine cards:

- Slot Mezz1\_Fabric\_C and slot Mezz3\_Fabric\_C support Fabric C. They must match the fabric type of the I/O modules installed in I/O module slots C1 and C2.
- Slot Mezz2\_Fabric\_B and slot Mezz4\_Fabric\_B support Fabric B. They must match the fabric type of the I/O modules installed in I/O module slots B1 and B2.

### Half-Height Blades

Half-height blades support two mezzanine cards:

- Mezzanine card slot C supports Fabric C. This card must match the fabric type of I/O modules installed in I/O module slots C1 and C2.
- Mezzanine card slot B supports Fabric B. This card must match the fabric type of I/O modules installed in I/O module slots B1 and B2.

See "I/O Module Mezzanine Cards" on page 217 for more information on mezzanine cards.

Table 1-13 shows various supported combinations of mezzanine cards and I/O modules.

**Table 1-13. Supported I/O Module Configurations**

<b>Fabric A</b>	<b>Fabric B Mezzanine Card</b>	<b>Fabric C Mezzanine Card</b>	<b>I/O Bay A1, A2</b>	<b>I/O Bay B1, B2</b>	<b>I/O Bay C1, C2</b>
Standard Integrated LOM	none	none	Ethernet switch module or pass- through module	none	none
Standard Integrated LOM	Ethernet mezzanine card	none	Ethernet switch module or pass- through module	Ethernet switch module or pass- through module	none
Standard Integrated LOM	none	Infiniband mezzanine card	Ethernet switch module or pass- through module	none	Infiniband switch module
Standard Integrated LOM	Ethernet mezzanine card	Ethernet mezzanine card	Ethernet switch module or pass- through module	Ethernet switch module or pass- through module	Ethernet switch module or pass- through module
Standard Integrated LOM	Fibre Channel mezzanine card	Infiniband mezzanine card	Ethernet switch module or pass- through module	Fibre Channel switch or pass- through module	Infiniband switch module

**Table 1-13. Supported I/O Module Configurations (continued)**


<b>Fabric A</b>	<b>Fabric B Mezzanine Card</b>	<b>Fabric C Mezzanine Card</b>	<b>I/O Bay A1, A2</b>	<b>I/O Bay B1, B2</b>	<b>I/O Bay C1, C2</b>
Standard Integrated LOM	none	Fibre Channel mezzanine card	Ethernet switch module or pass-through module	none	Fibre Channel switch module or pass-through module
Standard Integrated LOM	Fibre Channel mezzanine card	Fibre Channel mezzanine card	Ethernet switch module or pass-through module	Fibre Channel switch or pass-through module	Fibre Channel switch or pass-through module
Standard Integrated LOM	Ethernet mezzanine card	Fibre Channel mezzanine card	Ethernet switch module or pass-through module	Ethernet switch module or pass-through module	Fibre Channel switch or pass-through module
Standard Integrated LOM	Infiniband mezzanine card	Infiniband mezzanine card	Ethernet switch module or pass-through module	Infiniband switch module	Infiniband switch module
Standard Integrated LOM	Infiniband mezzanine card	Ethernet mezzanine card	Ethernet switch module or pass-through module	Infiniband switch module	Ethernet switch module or pass-through module

**Table 1-13. Supported I/O Module Configurations (continued)**

<b>Fabric A</b>	<b>Fabric B Mezzanine Card</b>	<b>Fabric C Mezzanine Card</b>	<b>I/O Bay A1, A2</b>	<b>I/O Bay B1, B2</b>	<b>I/O Bay C1, C2</b>
Standard Integrated LOM	Fibre Channel mezzanine card	Ethernet mezzanine card	Ethernet switch module or pass-through module	Fibre Channel switch or pass-through module	Ethernet switch module or pass-through module

### I/O Module Port Mapping

The LOM and optional mezzanine cards are mapped to the I/O module ports based on the following rules.

 **NOTE:** The I/O port mappings in the following sections are applicable only to the I/O Pass-Through Modules.


### Full-Height Blades

#### Standard LOM (Dual-Port) Mapping

Each LOM has two port connections. For a full-height blade in bay *n*:

- Integrated LOM1, connection 1 connects to I/O module A1, port *n*. Integrated LOM1, connection 2 connects to I/O module A2, port *n*.
- Integrated LOM2, connection 1 connects to I/O module A1, port *n*+8. Integrated LOM2, connection 2 connects to I/O module A2, port *n*+8.

For example, in a full-height blade in slot 5, integrated LOM1 connection 1 connects to I/O module A1, port 5 and LOM1 connection 2 connects to I/O module A2 port 5. LOM2 connection 1 connects to I/O module A1, port 13 and LOM2 connection 2 connects to I/O module A2, port 13.

 **NOTE:** Even though PowerEdge M610x is a full-height blade system, only one network controller (LOM1) is available.

For PowerEdge M610x blade in bay *n*:

- The integrated NIC connects to I/O module A1, port *n* and I/O module A2, port *n*

### Dual-Port Mezzanine Cards

Each mezzanine card has two port connections. For a full-height blade in bay  $n$ :

- Mezzanine card 1, connection 1 connects to I/O module C1, port  $n$ .  
Mezzanine card 1, connection 2 connects to I/O module C2, port  $n$ .
- Mezzanine card 2, connection 1 connects to I/O module B1, port  $n$ .  
Mezzanine card 2, connection 2 connects to I/O module B2 port  $n$ .
- Mezzanine card 3, connection 1 connects to I/O module C1, port  $n+8$ .  
Mezzanine card 3, connection 2 connects to I/O module C2 port  $n+8$ .
- Mezzanine card 4, connection 1 connects to I/O module B1, port  $n+8$ .  
Mezzanine card 4, connection 2 connects to I/O module B2 port  $n+8$ .

For example, in a full-height blade mezzanine card 3, connection 1 connects to I/O module C1, port 13 and Mezzanine card 3, connection 2 connects to I/O module C2 port 13. Table 1-15 shows the port number assignments for the eight possible full height blade locations.



**NOTE:** Even though PowerEdge M610x is a full blade system, only two mezzanine card slots (MEZZ1\_Fab\_C1 and MEZZ2\_FAB\_B1) in the expansion bay are available for use. The other two slots on the system board (MEZZ1\_FAB\_C and MEZZ2\_FAB\_B) are occupied by the mezzanine interface card which provides connectivity between the PCIe expansion-card riser and the system board.

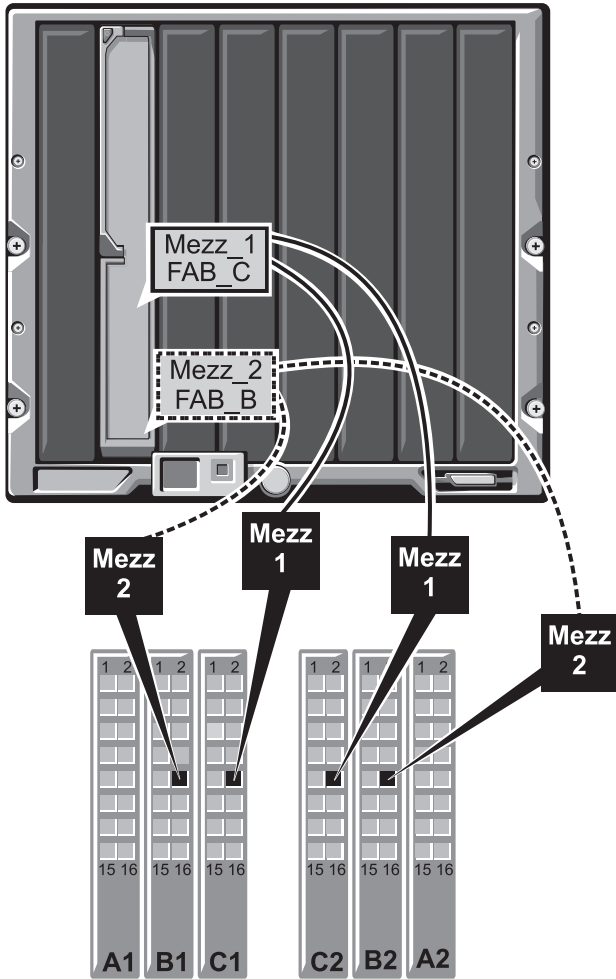
For PowerEdge M610x in bay  $n$ :

- Mezzanine card B (in the expansion bay) connects to I/O module B1, port  $n+8$  and I/O module B2, port  $n+8$ .
- Mezzanine card C (in the expansion bay) connects to I/O module C1, port  $n+8$  and I/O module C2, port  $n+8$ .

**Table 1-14. Example of I/O Module Port Assignments - PowerEdge M610x in Slot 2**

Blade 2	I/O Module					
	A1	B1	C1	C2	B2	A2
Mezzanine Card C			Port 10	Port 10		
Mezzanine Card B		Port 10			Port 10	

**Figure 1-24. Example of PowerEdge M610x Port Mapping of – Blade 2**





**Table 1-15. I/O Module Port Assignments - Full-Height Blades (not applicable for PowerEdge M610x)**

<b>Blade 1</b>	<b>I/O Module</b>			
	<b>B1</b>	<b>C1</b>	<b>C2</b>	<b>B2</b>
Mezz1_Fab_C		Port 1	Port 1	
Mezz2_Fab_B	Port 1			Port 1
Mezz3_Fab_C		Port 9	Port 9	
Mezz4_Fab_B	Port 9			Port 9

<b>Blade 2</b>	<b>I/O Module</b>			
	<b>B1</b>	<b>C1</b>	<b>C2</b>	<b>B2</b>
Mezz1_Fab_C		Port 2	Port 2	
Mezz2_Fab_B	Port 2			Port 2
Mezz3_Fab_C		Port 10	Port 10	
Mezz4_Fab_B	Port 10			Port 10

<b>Blade 3</b>	<b>I/O Module</b>			
	<b>B1</b>	<b>C1</b>	<b>C2</b>	<b>B2</b>
Mezz1_Fab_C		Port 3	Port 3	
Mezz2_Fab_B	Port 3			Port 3
Mezz3_Fab_C		Port 11	Port 11	
Mezz4_Fab_B	Port 11			Port 11

<b>Blade 4</b>	<b>I/O Module</b>			
	<b>B1</b>	<b>C1</b>	<b>C2</b>	<b>B2</b>
Mezz1_Fab_C		Port 4	Port 4	
Mezz2_Fab_B	Port 4			Port 4
Mezz3_Fab_C		Port 12	Port 12	
Mezz4_Fab_B	Port 12			Port 12

<b>Blade 5</b>	<b>I/O Module</b>			
	<b>B1</b>	<b>C1</b>	<b>C2</b>	<b>B2</b>
Mezz1_Fab_C		Port 5	Port 5	
Mezz2_Fab_B	Port 5			Port 5
Mezz3_Fab_C		Port 13	Port 13	
Mezz4_Fab_B	Port 13			Port 13

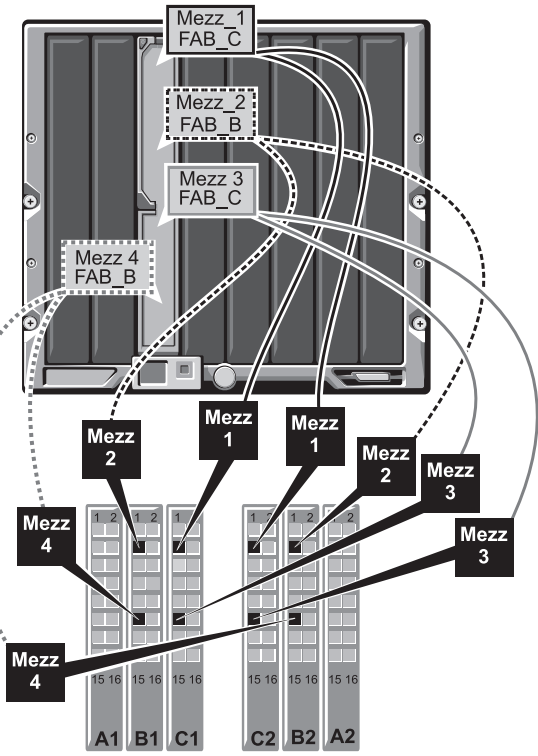
<b>Blade 6</b>	<b>I/O Module</b>			
	<b>B1</b>	<b>C1</b>	<b>C2</b>	<b>B2</b>
Mezz1_Fab_C		Port 6	Port 6	
Mezz2_Fab_B	Port 6			Port 6
Mezz3_Fab_C		Port 14	Port 14	
Mezz4_Fab_B	Port 14			Port 14

<b>Blade 7</b>	<b>I/O Module</b>			
	<b>B1</b>	<b>C1</b>	<b>C2</b>	<b>B2</b>
Mezz1_Fab_C		Port 7	Port 7	
Mezz2_Fab_B	Port 7			Port 7
Mezz3_Fab_C		Port 15	Port 15	
Mezz4_Fab_B	Port 15			Port 15

Blade 8	I/O Module			V
	B1	C1	C2	B2
Mezz1_Fab_C		Port 8	Port 8	
Mezz2_Fab_B	Port 8			Port 8
Mezz3_Fab_C		Port 16	Port 16	
Mezz4_Fab_B	Port 16			Port 16

Figure 1-25 shows the port connections for a full-height blade in bay 3 with four mezzanine cards.

**Figure 1-25. Example of Full-Height Blade Port Mapping – Blade 3 (not applicable for PowerEdge M610x)**



### Quad-Port Mezzanine Cards

Table 1-16 illustrates the I/O module port mapping for full-height blades with quad-port mezzanine cards.



**NOTE:** For a detailed mapping of each PowerEdge system, see the document *Quadport Capable Hardware for the M1000e Modular Chassis* on [support.dell.com/manuals](http://support.dell.com/manuals).

**Table 1-16. I/O Module Port Assignments—Full-Height Blades (not applicable for PowerEdge M610x)**

Blade $n$ and Blade ( $n + 8$ )	I/O Module			
	B1	C1	C2	B2
<b>NOTE:</b> $n$ denotes a variable value from 1 to 8.				
Mezz_FAB_B_Blade $n$ _Port1	Port $n$			
Mezz_FAB_B_Blade $n$ _Port2				Port $n$
Mezz_FAB_B_Blade $n$ _Port3	Port ( $n+16$ )			
Mezz_FAB_B_Blade $n$ _Port4				Port ( $n+16$ )
Mezz_FAB_C_Blade $n$ _Port1		Port $n$		
Mezz_FAB_C_Blade $n$ _Port2			Port $n$	
Mezz_FAB_C_Blade $n$ _Port3		Port ( $n+16$ )		
Mezz_FAB_C_Blade $n$ _Port4			Port ( $n+16$ )	
Mezz_FAB_B_Blade $n+8$ _Port1	Port ( $n+8$ )			
Mezz_FAB_B_Blade $n+8$ _Port2				Port ( $n+8$ )
Mezz_FAB_B_Blade $n+8$ _Port3	Port ( $n+24$ )			
Mezz_FAB_B_Blade $n+8$ _Port4				Port ( $n+24$ )
Mezz_FAB_C_Blade $n+8$ _Port1		Port ( $n+8$ )		

**Table 1-16. I/O Module Port Assignments—Full-Height Blades (continued)(not applicable for PowerEdge M610x)**

Blade <i>n</i> and Blade ( <i>n</i> + 8)	I/O Module			
	B1	C1	C2	B2
Mezz_FAB_C_Blade <i>n</i> +8_Port2			Port ( <i>n</i> +8)	
Mezz_FAB_C_Blade <i>n</i> +8_Port3		Port ( <i>n</i> +24)		
Mezz_FAB_C_Blade <i>n</i> +8_Port4			Port ( <i>n</i> +24)	



**NOTE:** Even though PowerEdge M610x is a full blade system, only two mezzanine card slots (MEZZ1\_Fab\_C1 and MEZZ2\_FAB\_B1) in the expansion bay are available for use. The other two slots on the system board (MEZZ1\_FAB\_C and MEZZ2\_FAB\_B) are occupied by the mezzanine interface card which provides connectivity between the PCIe expansion-card riser and the system board.

Table 1-17 illustrates the I/O module port mapping for PowerEdge M610x in bay *n*.

**Table 1-17. Example of I/O Module Port Assignments - PowerEdge M610x Blade 1**

Blade 1	I/O Module					
	A1	B1	C1	C2	B2	A2
Mezzanine Card C (port 1 and port 2)			Port 9	Port 9		
Mezzanine Card C (port 3 and port 4)			Port 25	Port 25		
Mezzanine Card B (port 1 and port 2)		Port 9			Port 9	
Mezzanine Card B (port 1 and port 2)		Port 25			Port 25	

## Half-Height Blades

### ***Standard LOM (Dual-Port) and Network Daughter Card (Quad-Port) Mapping***

Each standard LOM has two port connections. For a half-height blade in bay  $n$ :

- Integrated LOM, connection 1 connects to I/O module A1, port  $n$ .  
Integrated LOM, connection 2 connects to I/O module A2, port  $n$ .

Half-height blades with Network Daughter Card (PowerEdge M710HD) hosts two network controllers (LOM1 and LOM2), each with two port connections. For a half-height blade in bay  $n$ :

- LOM1, connection 1 connects to I/O module A1, port  $n$ .  
LOM1, connection 2 connects to I/O module A2, port  $n$ .
- LOM2, connection 1 connects to I/O module A1, port  $n+16$ .  
LOM2, connection 2 connects to I/O module A2, port  $n+16$ .



**NOTE:** If the I/O modules A1 and A2 are not quad-port capable, then the LOM2 ports (NIC3 and NIC4) gets disabled during system boot. For more information, see "Port Auto-Disablement in Quad-Port Network Daughter Card (PowerEdge M710HD Only)" on page 53.

For example, in a half-height blade in slot 5, integrated LOM1 connection 1 connects to I/O module A1, port 5 and LOM1 connection 2 connects to I/O module A2, port 5. LOM2 connection 1 connects to I/O module A1, port 21 and LOM2 connection 2 connects to I/O module A2, port 21.

### ***Dual-Port Mezzanine Cards***

For a half-height blade in bay  $n$ :

- The integrated NIC connects to I/O module A1, port  $n$  and I/O module A2, port  $n$ .
- Mezzanine card B connects to I/O module B1, port  $n$  and I/O module B2, port  $n$ .
- Mezzanine card C connects to I/O module C1, port  $n$  and I/O module C2, port  $n$ .

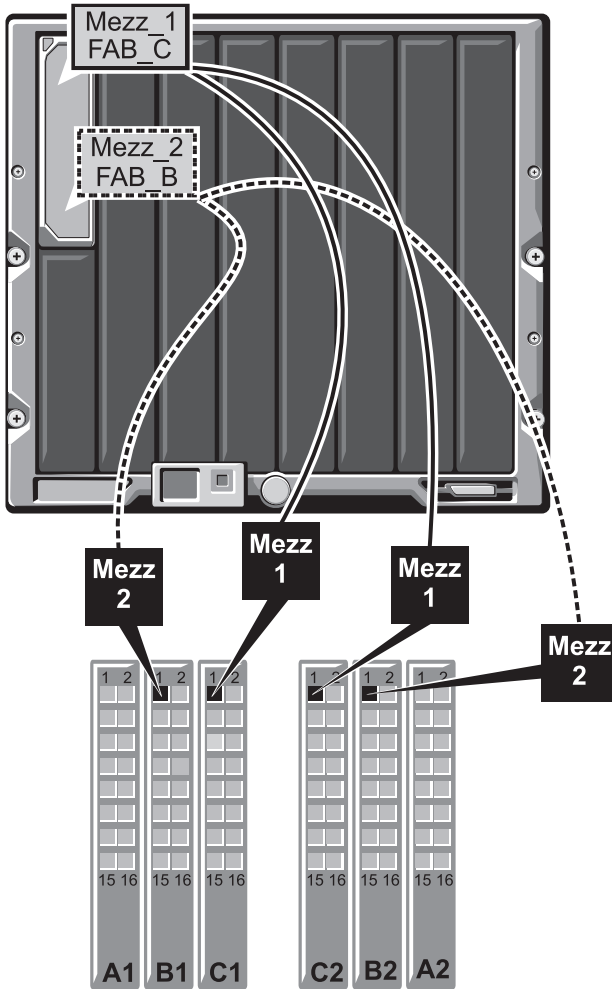
For example, in a blade in slot 12, the integrated NIC connects to I/O module A1, port 12 and I/O module A2, port 12.

**Table 1-18. Example of I/O Module Port Assignments - Half-Height Blade 1**

<b>Blade 1</b>	<b>I/O Module</b>					
	<b>A1</b>	<b>B1</b>	<b>C1</b>	<b>C2</b>	<b>B2</b>	<b>A2</b>
Integrated NIC	Port 1					Port 1
Mezzanine Card C			Port 1	Port 1		
Mezzanine Card B		Port 1			Port 1	

Figure 1-26 shows the port connections for a half-height blade in bay 1 with two mezzanine cards.

**Figure 1-26. Example of Half-Height Blade Port Mapping**





### Quad-Port Mezzanine Cards

Table 1-19 illustrates the I/O module port mapping for a half-height blade with the quad-port mezzanine card. In the following table,  $n$  denotes a variable value from 1 to 16.



**NOTE:** For a detailed mapping of each PowerEdge system, see the document *Quadport Capable Hardware For the M1000e Modular Chassis* on [support.dell.com/manuals](http://support.dell.com/manuals).

**Table 1-19. I/O Module Port Assignments—Half-Height Blades**

Blade $n$	I/O Module					
	A1	B1	C1	C2	B2	A2
Integrated LOM1	Port $n$					
Integrated LOM2	Port $n$					
Mezz_FAB_B_Blade $n$ _Port1	Port $n$					
Mezz_FAB_B_Blade $n$ _Port2	Port $n$					
Mezz_FAB_B_Blade $n$ _Port3	Port ( $n+16$ )					
Mezz_FAB_B_Blade $n$ _Port4	Port ( $n+16$ )					
Mezz_FAB_C_Blade $n$ _Port1	Port $n$					
Mezz_FAB_C_Blade $n$ _Port2	Port $n$					
Mezz_FAB_C_Blade $n$ _Port3	Port ( $n+16$ )					
Mezz_FAB_C_Blade $n$ _Port4	Port ( $n+16$ )					

### Dell PowerConnect-KR 8024-k Switch

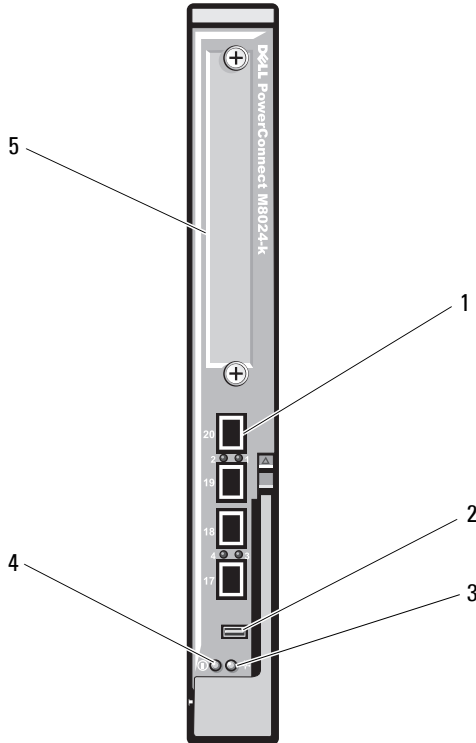
The PowerConnect M8024-k switch provides 16 internal 10 GbE ports, four external 10 GbE SFP+ ports, and one 10 GbE expansion slot for 10 GbE external uplinks. The expansion slot on the front panel can support:

- A 10 Gb Ethernet module with four optical SFP+ connectors
- A 10 Gb Ethernet module with three copper CX4 uplinks

- A 10 Gb Ethernet module with two copper 10GBASE-T uplinks

This module is hot-swappable and may be installed in Fabric A, B, or C.

**Figure 1-27. Dell PowerConnect-KR 8024-k Switch**



- |   |                 |   |                                 |
|---|-----------------|---|---------------------------------|
| 1 | SFP+ ports (4)  | 2 | console management connector    |
| 3 | power indicator | 4 | status/identification indicator |
| 5 | expansion slot  |   |                                 |

## Dell M8428-k 10 Gb Converged Network Switch

The Dell M8428-k 10 Gb Converged Network switch module supports FCoE protocols and allows Fibre Channel traffic to travel over 10 Gbps Converged Enhanced Ethernet (DCB) networks. This module consists of:

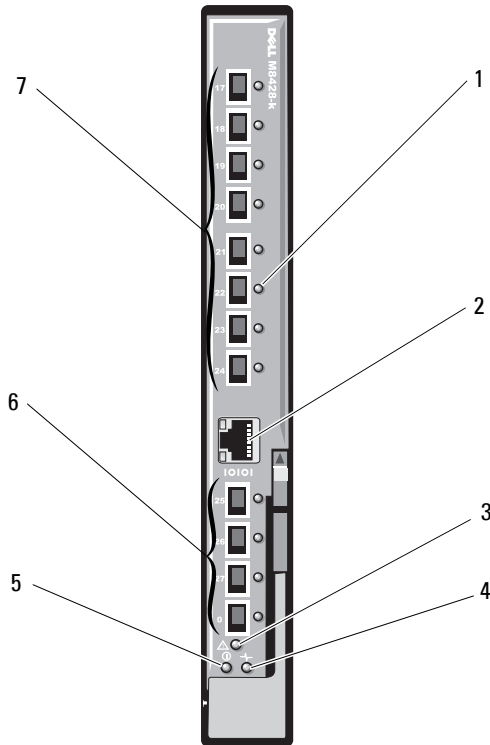
- Four 8 Gbps external autosensing Fibre Channel ports
- Eight 10 Gb Enhanced Ethernet (DCB) optical SFP+ port connectors
- Sixteen internal 10 Gb Enhanced Ethernet (DCB/FCoE) ports that link to the blades in the enclosure
- One serial port with an RJ-45 connector.

This Fibre Channel switch may be installed in either Fabric B or Fabric C.



**NOTE:** This switch module includes Short Wave Small Form Factor Pluggable (SFP) optical transceivers in the Fibre Channel ports. To ensure proper Fibre Channel functionality, use only SFPs provided with this module.

**Figure 1-28. Dell M8428-k 10 Gb Converged Network Switch**

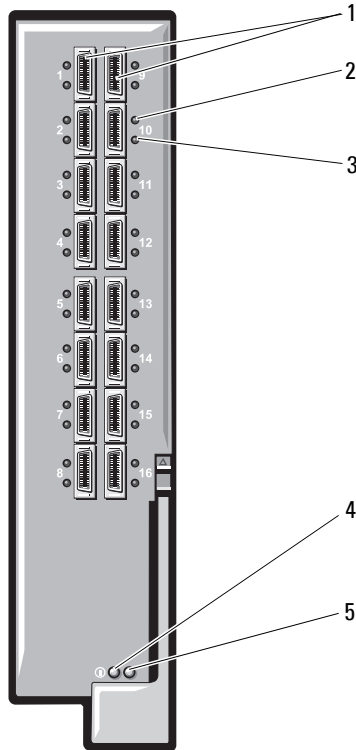


- |   |                             |   |  |
|---|-----------------------------|---|--|
| 1 | LED status indicators (12)  | 2 | serial port (RJ-45 connector)                        |
| 3 | module status indicator     | 4 | diagnostic status indicator                          |
| 5 | power indicator             | 6 | 8 Gb Fibre Channel ports<br>(ports 25–27 and port 0) |
| 7 | 10 GbEE ports (ports 17–24) |   |  |

## Mellanox M3601Q QDR Infiniband Switch I/O Module

The Mellanox M3601 Infiniband switch I/O module includes 32 4x QDR Infiniband ports. Of these, 16 ports are external uplink ports, while 16 internal ports provide connectivity to the blades in the enclosure. This module occupies two I/O module slots. The M3601Q module plugs into I/O module slot C1, but occupies both slots B1 and C1.

**Figure 1-29. Mellanox M3601Q Infiniband Switch Module**

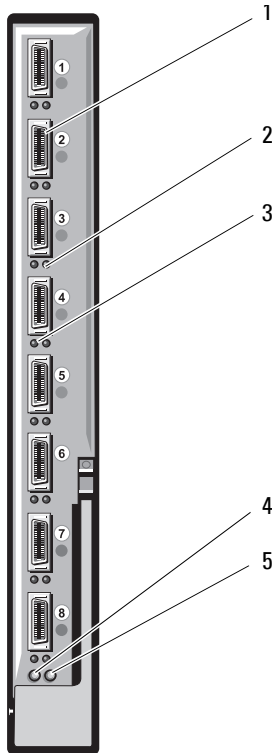


- |   |                               |   |                                   |
|---|-------------------------------|---|-----------------------------------|
| 1 | Infiniband ports (16)         | 2 | port link status indicators (16)  |
| 3 | port activity indicators (16) | 4 | module diagnostic power indicator |
| 5 | module status indicator       |   |                                   |

## Mellanox M2401G Infiniband Switch I/O Module

The Mellanox M2401G Infiniband switch I/O module includes 24 4x DDR Infiniband ports. Eight ports are external uplink ports, while 16 internal ports provide connectivity to the blades in the enclosure.

**Figure 1-30. Mellanox M2401G Infiniband Switch Module**



- |   |                              |   |                                 |
|---|------------------------------|---|---------------------------------|
| 1 | Infiniband ports (8)         | 2 | port link status indicators (8) |
| 3 | port activity indicators (8) | 4 | diagnostic power indicator      |
| 5 | status indicator             |   |                                 |

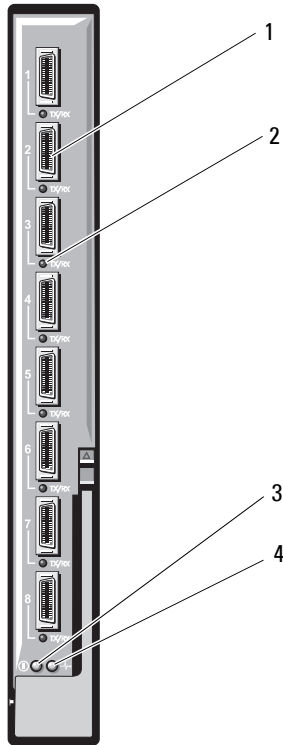
**Table 1-20. Mellanox M2401G Infiniband Switch Indicators**

<b>Indicator</b>	<b>Pattern</b>	<b>Description</b>
Link indicator	Green, on	Physical link established
	Green, off	No physical link present
Activity indicator	Amber, on	Valid logical link to Infiniband network established
	Amber, blinking	Data transfer is in progress
	Amber, off	No logical link to Infiniband network

### **Cisco SFS M7000e Infiniband Switch Module**

The Cisco SFS M7000e Infiniband switch module includes 24 4x DDR Infiniband ports. Eight ports are external uplink ports, and 16 internal ports provide connectivity to the blades in the enclosure. This switch module is hot-swappable, and may be installed in Fabric B or Fabric C. For general information on installing this module, see "I/O Modules" on page 296.

**Figure 1-31. Cisco SFS M7000e Infiniband Switch Module Features**



- |   |                             |   |                           |
|---|-----------------------------|---|---------------------------|
| 1 | Infiniband ports (8)        | 2 | port status indicator (8) |
| 3 | diagnostic status indicator | 4 | power indicator           |

**Table 1-21. Cisco SFS M7000e Infiniband Switch Indicators**

Indicator Type	Pattern	Description
Infiniband port status indicator	Off	Link error or Subnet Manager not operating
	Green flickering	I/O activity on port
	Green on	Link established



**Table 1-21. Cisco SFS M7000e Infiniband Switch Indicators (continued)**

Indicator Type	Pattern	Description
Module status indicator	Off	Switch is not ready
	Blue on	Switch operating normally
	Amber on or blinking	Fault condition in module
Module power indicator	Off	Power to the module is off
	Green	Module has power

### Cisco Ethernet Switch

Your system supports three Cisco Catalyst Blade Switch (CBS) versions:

- The Cisco 3130G-S switch includes four 10/100/1000 Mb Ethernet uplink ports and two Stackwise Plus ports.
- The Cisco CBS 3130X-S switch includes four 10/100/1000 Mb Ethernet uplink ports, two 10 Gb uplink ports, and two Stackwise Plus ports.
- The Cisco CBS 3032 switch includes four 10/100/1000 Mb Ethernet uplink ports.

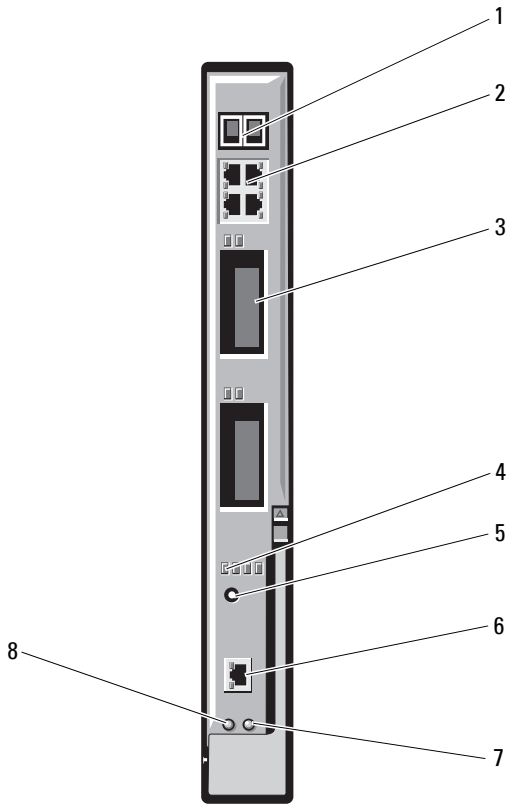
The two option bays support the following module options:

- Cisco X2 10 Gb transceiver modules (CBS 3130X-S only)
- Cisco TwinGig converter modules

All three switches include a RJ-45 console connector for switch management. Sixteen internal Gb Ethernet connectors link to the blades in the enclosure. See Figure 1-32.

For additional information about the Cisco CBS Ethernet switch modules, see the documentation that shipped with the module. For general information on installing this module, see "I/O Modules" on page 296.

**Figure 1-32. Cisco Ethernet Switch Module Features**



- |   |   |   |  |
|---|---|---|--|
| 1 | Stackwise Plus connectors (not enabled in CBS 3032) | 2 | 10/100/1000 Mb Ethernet connectors (4) |
| 3 | option bays (2)                                     | 4 | Cisco status indicators                |
| 5 | mode button   | 6 | console port for switch management     |
| 7 | status/identification indicator                     | 8 | power indicator                        |

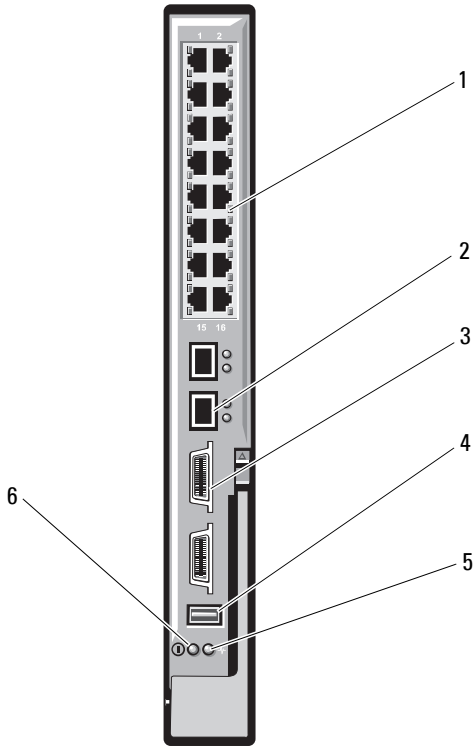
## **PowerConnect M6348 1 Gb Ethernet Switch I/O Module**

The PowerConnect M6348 is a hot-swappable 48-port 1 Gb Ethernet switch. While 16 ports are external uplink ports, the remaining 32 internal ports provide connectivity to the blades within the enclosure with a maximum bandwidth of 1 Gbps each. The PowerConnect M6348 switch also supports:

- Two integrated 10 Gb Ethernet SFP+ connectors
- Two integrated CX4 stacking connectors
- One console management connector

It is recommended that you use the PowerConnect M6348 switch with quad-port mezzanine cards for maximum functionality. The quad-port mezzanine cards and the PowerConnect M6348 Ethernet switch enable an increased bandwidth (two 1 Gbps lanes), higher port density, and server module consolidation.

**Figure 1-33. PowerConnect M6348 Switch Module**



- |   |  |   |                              |
|---|--|---|------------------------------|
| 1 | standard 10/100/1000 Mb Ethernet connectors (16) | 2 | SFP+ connectors (2)          |
| 3 | CX4 stacking connectors (2)                      | 4 | console management connector |
| 5 | status/identification indicator                  | 6 | power indicator              |

## PowerConnect M8024 10 Gb Ethernet Switch I/O Module

The PowerConnect M8024 switch module incorporates two option bays that support the following modules:

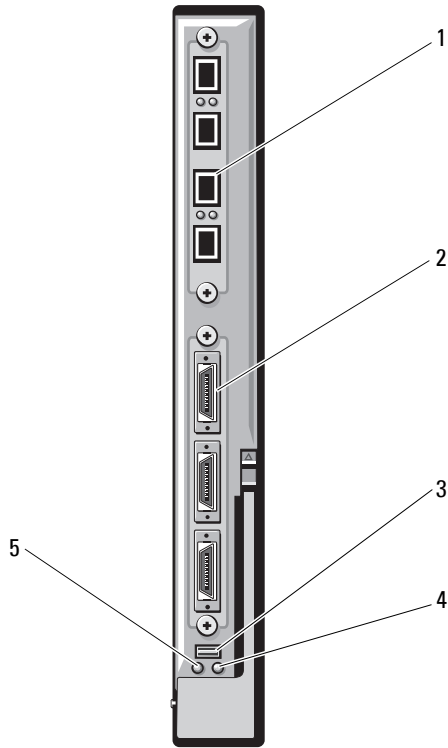
- A 10 Gb Ethernet module with four optical SFP+ connectors
- A 10 Gb Ethernet module with three copper CX4 uplinks

You can initially configure the switch using either of two methods:

- Connect an external management system to the switch using an USB type-A form factor serial cable, and configure the switch using a terminal application.
- Use the iKVM CMC console (“17th blade”) and the **connect switch-*n*** CMC CLI command. For more information, see the CMC user’s guide.

Once an IP address is assigned to the management VLAN or interface and the switch is connected to a management network, both Telnet and http are available through the network.

**Figure 1-34. PowerConnect M8024 Switch Module**



- |   |  |   |                                      |
|---|--|---|--------------------------------------|
| 1 | optional module with four SFP+ ports                       | 2 | optional module with three CX4 ports |
| 3 | serial connector for optional USB type-A form-factor cable | 4 | status/identification indicator      |
| 5 | power indicator  |   |                                      |

## **PowerConnect M6220 Ethernet Switch Module**

The PowerConnect M6220 Ethernet switch module includes four external 10/100/1000 Mbps Ethernet connectors and one USB type A form factor serial connector. See Figure 1-35.

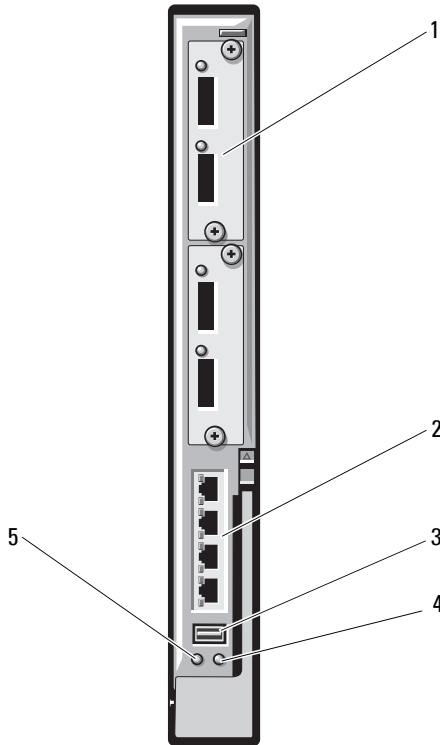
Two option bays support the following three module options:

- A resilient stacking module with 2 x 24 Gb stacking ports
- A 10 Gb Ethernet module with two 10 Gb optical XFP connectors
- A 10 Gb Ethernet module with two copper CX4 uplinks

Installing two optional modules provides additional stacking and redundancy support. Sixteen internal Gb Ethernet connectors link to the blades in the enclosure.

For additional information about the PowerConnect M6220 Ethernet switch module, see the documentation that shipped with the module. For general information on installing this module, see "I/O Modules" on page 296.

**Figure 1-35. PowerConnect M6220 Ethernet Switch Module Features**



- |   |   |   |   |
|---|---|---|---|
| 1 | optional module (2) (dual 10 Gb Ethernet uplink module shown) | 2 | standard 10/100/1000 Mb Ethernet connectors (4) |
| 3 | serial connector (USB type-A form factor)                     | 4 | status/identification indicator                 |
| 5 | power indicator   |   |   |

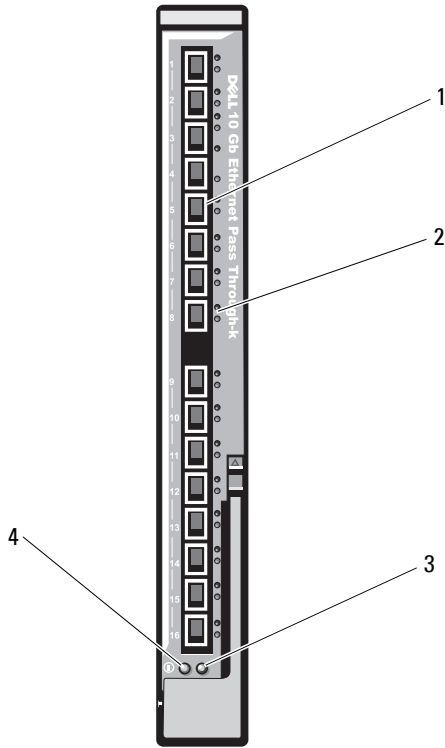


## **Dell 10 GbE KR Pass-Through I/O Module**

The 10 GbE KR pass-through module supports 10 Gb connections and provides a direct connection between the optional internal Ethernet KR mezzanine card or KR network daughter card in the blade and an external Ethernet device. This module has 16 external SFP+ ports on the front panel and sixteen 10 GbE KR internal ports through the backplane. This module enables you to use optical SFP+ (short reach or long reach) and direct-attached copper (DCA) SFP+ modules.

The Ethernet pass-through module is hot-swappable and may be installed in Fabric A, B, or C. The pass-through module does not support 1G mezzanine or network daughter cards in blades.

**Figure 1-36. Dell 10 GbE KR Pass-Through I/O Module**



- |   |                                 |   |                                       |
|---|---------------------------------|---|---------------------------------------|
| 1 | SFP+ ports (16)                 | 2 | green/amber indicators (two per port) |
| 3 | status/identification indicator | 4 | power indicator                       |

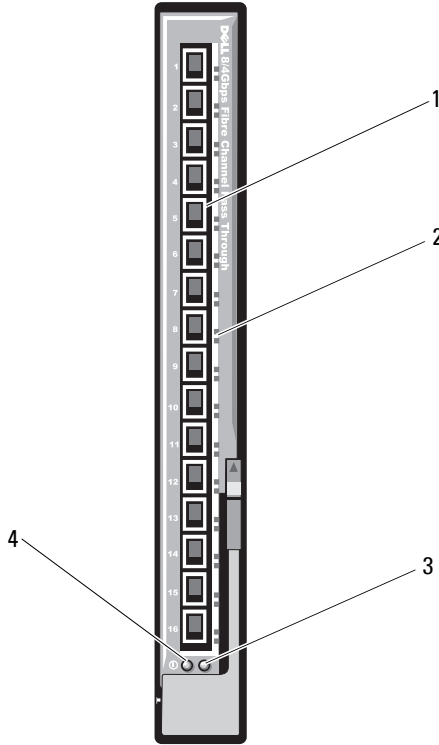
### **Dell 8/4 Gbps Fibre Channel Pass-Through I/O Module**

The 8G Fibre Channel pass-through module provides a bypass connection between a Fibre Channel mezzanine card in the blade and optical transceivers. The bypass connection enables a direct connection to a Fibre Channel switch or a storage array. The 16 pass-through ports on this module can negotiate speeds of 2,4, and 8 Gbps. The 8G Fibre Channel pass-through module is hot-swappable and may be installed in Fabric B or Fabric C.



**NOTE:** To ensure proper functionality, use only the Short Wave Small Form Factor Pluggable (SFP) transceivers provided with this module.

**Figure 1-37. Dell 8/4 Gbps Fibre Channel Pass-Through I/O Module**



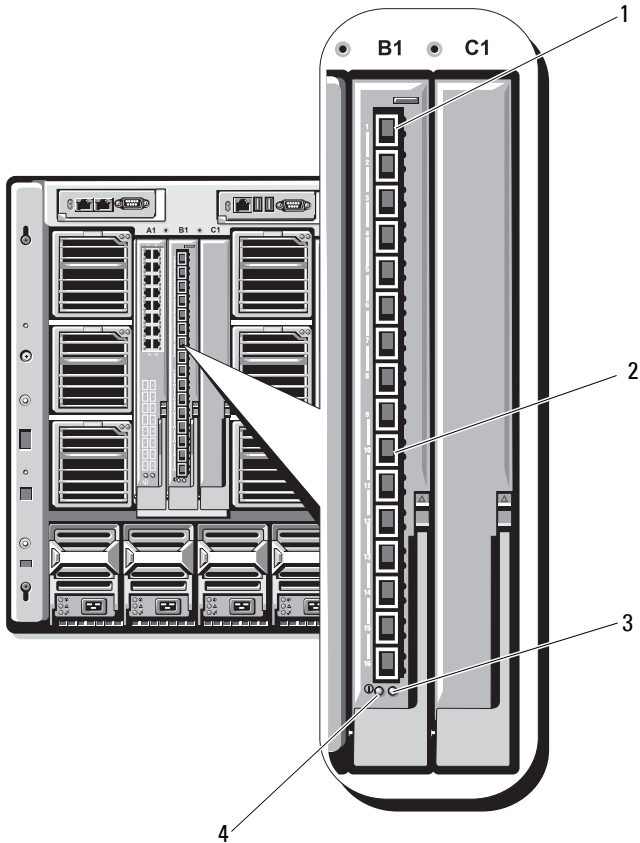
- |   |                                 |   |                        |
|---|---------------------------------|---|------------------------|
| 1 | Fibre Channel ports (16)        | 2 | port status indicators |
| 3 | status/identification indicator | 4 | power indicator        |

## **10 Gb Ethernet Pass-Through Module II**

The Dell 10 Gb Ethernet pass-through module II supports 10 Gb connections and provides a direct connection between the optional internal Ethernet mezzanine card in the blade and an external Ethernet device. The Ethernet pass-through modules are hot-swappable and may be installed in Fabric B or Fabric C.

The 10 Gb Ethernet pass-through module II enables you to use optical SFP+ and direct-attached copper (DCA) SFP+ modules. To operate at 10 Gbps, you must use either optical SFP+ short reach (SR), long reach (LR), or DCA SFP+ modules.

**Figure 1-38. 10 Gb Ethernet Pass-Through Module II**



- |   |                                 |   |                                       |
|---|---------------------------------|---|---------------------------------------|
| 1 | SFP+ cages (16)                 | 2 | green/amber indicators (two per port) |
| 3 | status/identification indicator | 4 | power indicator                       |

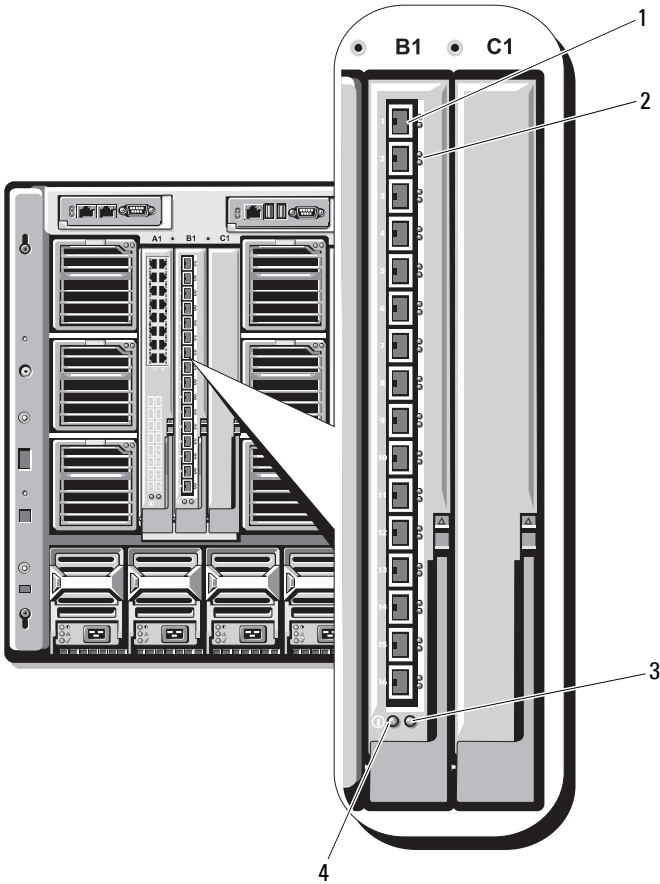
## 10 Gb Ethernet Pass-Through I/O Module

The 10 Gb Ethernet pass-through module supports 1/10 Gb connections and provides a direct connection between the optional internal Ethernet mezzanine card in the blade and an external Ethernet device. The Ethernet pass-through modules are hot-swappable and may be installed in Fabric B or Fabric C.

The 10 Gb Ethernet pass-through I/O module enables you to use optical SFP, SFP+, and direct-attached copper (DCA) SFP+ modules. The I/O module and the SFP+ modules can operate at either 1 Gbps or 10 Gbps under the following conditions:

- To operate at 10 Gbps, you must use either optical SFP+ short reach (SR), long reach multimode (LRM), or DCA SFP+ modules.
- To operate at 1 Gbps, you must use optical SFP transceivers that support a data rate of 1 Gbps. While connecting at 1 Gbps to an external switch, the external switch must be set to the forced 1G mode and the auto-negotiation option must be turned off.

**Figure 1-39. 10 Gb Ethernet Pass-Through I/O Module Features**



- |   |                                 |   |                                       |
|---|---------------------------------|---|---------------------------------------|
| 1 | SFP+ cages (16)                 | 2 | green/amber indicators (two per port) |
| 3 | status/identification indicator | 4 | power indicator                       |

## 4 Gbps Fibre Channel Pass-Through Module

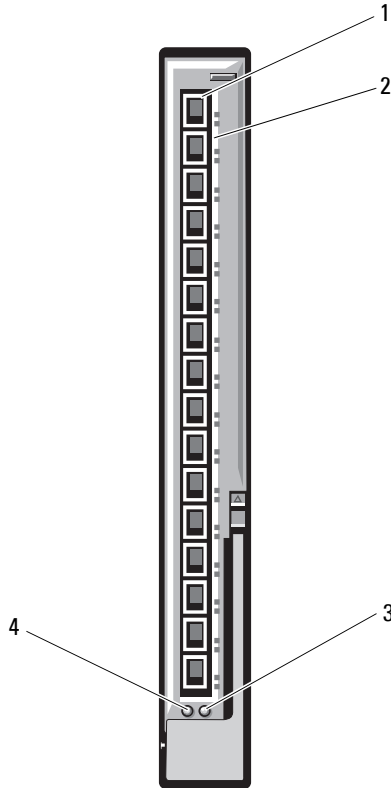
The 4 Gbps Fibre Channel pass-through module provides a bypass connection between a Fibre Channel mezzanine card in the blade and optical transceivers for direct connection into a Fibre Channel switch or a storage array (see Figure 1-40). The 16 pass-through ports on this module can negotiate speeds of 1-, 2-, or 4-Gbps. The 4 Gbps Fibre Channel pass-through modules are hot-swappable, and may be installed in Fabric B or Fabric C. Table 1-22 lists the functionality of the indicators on each individual Fibre Channel connector. For general information on installing this module, see "I/O Modules" on page 296.



**NOTE:** To ensure proper functionality, use only the Short Wave Small Form Factor Pluggable (SFP) transceivers provided with this module.



**Figure 1-40. 4 Gbps Fibre Channel Pass-Through Module Features**



- |   |                                  |   |   |
|---|----------------------------------|---|---|
| 1 | SFP Fibre Channel connector (16) | 2 | Fibre Channel green/amber indicators (two per port) |
| 3 | status/identification indicator  | 4 | power indicator                                     |

**Table 1-22. Fibre Channel Pass-Through Indicators**

<b>Indicator Type</b>	<b>Pattern</b>	<b>Description</b>
Power indicator	Off	Power to the module is off
	Green	Module has power
Status/identification indicator	Blue on	Primary module in a stack, if applicable
	Blue off	Secondary module in a stack
	Amber flashing	Fault condition in module
Fibre Channel port indicators with Emulex mezzanine card installed	Green off, amber off	Mezzanine board failure before POST
	Green off, amber on or green off, amber blinking	Mezzanine board failure during POST
	Green off, amber flashing irregularly	POST in progress
	Green on, amber off or green on, amber on	Mezzanine board failure during operation
	Green on, one fast amber blink	1 Gb link established
	Green on, two fast amber blinks	2 Gb link established
	Green on, three fast amber blinks	4 Gb link established
	Slow green blinking, amber off	No link established
	Slow green blinking, slow amber blinking	Offline for firmware download

**Table 1-22. Fibre Channel Pass-Through Indicators (continued)**

Indicator Type	Pattern	Description
Fibre Channel Port LEDs with Qlogic mezzanine card Installed	Green off, amber off	Power off
	Green off, amber on	Online, 1 Gb or 2 Gb link
	Green on, amber off	Online, 4 Gb link
	Green off, amber flashing	I/O activity, 1 Gb or 2 Gb
	Green flashing, amber off	I/O activity, 4 Gb
	Green flashing and amber flashing at same time	Loss of synchronization
	Green flashing and amber flashing at different intervals	Firmware error
Off/amber flashing (twice per second)	Connection has lost synchronization.	

### Brocade M5424 FC8 I/O Module

The Brocade M5424 I/O module includes eight external autosensing Fibre Channel ports (four ports are enabled in the standard configuration and four additional ports may be enabled as an optional upgrade), 16 internal ports, and one serial port with an RJ-45 connector. The external Fibre Channel ports operate at 8 Gb/sec, 4 Gb/sec, or 2 Gb/sec.

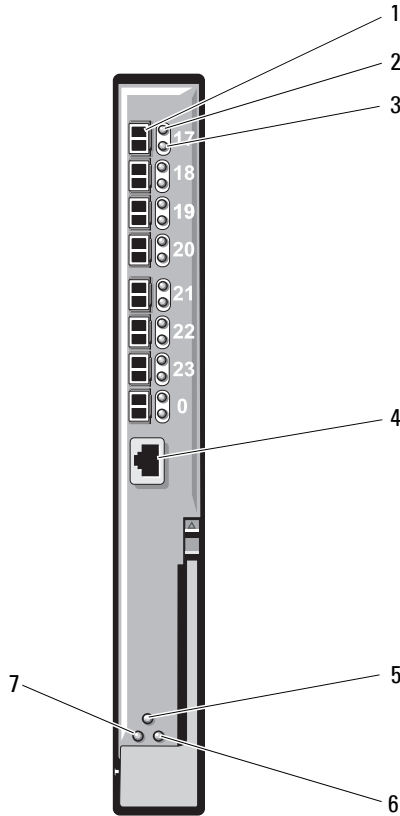


**NOTE:** CMC firmware version 1.3 is required to support FC8 mezzanine cards and I/O modules.



**NOTE:** This Fibre Channel switch module includes Short Wave Small Form Factor Pluggable (SFP) optical transceivers. To ensure proper functionality, use only SFPs provided with this module.

**Figure 1-41. Brocade M5424 FC8 I/O Module**



- |   |  |   |   |
|---|--|---|---|
| 1 | Fibre Channel port (8)                 | 2 | Fibre Channel port status indicator (8) |
| 3 | Fibre Channel port speed indicator (8) | 4 | serial port (RJ-45 connector)           |
| 5 | module status indicator                | 6 | status/identification indicator         |
| 7 | power indicator                        |   |   |

**Table 1-23. Brocade M5424 FC8 I/O Module indicators**

<b>Indicator Type</b>	<b>Pattern</b>	<b>Description</b>
Fibre Channel port status indicator	Off	No signal carrier
	Amber on	Signal present but not online
	Green on	Online, but no activity
	Green blinking slowly	Online but segmented
	Green blinking quickly	Internal loopback
	Green flickering	I/O activity on port
	Amber blinking slowly	Port disabled
Fibre Channel port speed indicator	Amber blinking rapidly	Error or fault with port
	Off	2 Gb link established
	Green on	4 Gb link established
Module status indicator	Amber on	8 Gb link established
	Off	Module is off or enclosure power is off
	Green on	All ports are ready for use
Module power indicator	Amber on	Module is booting being reset, or ports are offline
	Green/amber blinking	Diagnostic message is in error log, or environmental range is exceeded
	Off	Power to the module is off
Status/identification indicator	Green	Module has power
	Blue on	Primary module in a stack, if applicable
	Blue off	Secondary module in a stack
	Amber flashing	Fault condition in module

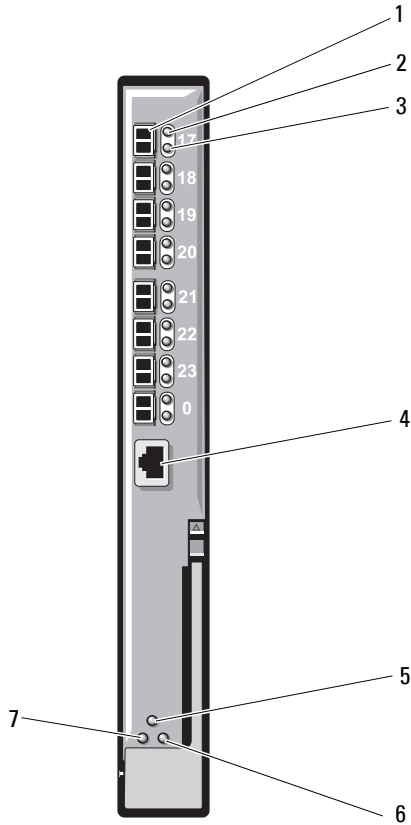
## Brocade M4424 SAN I/O Module

The Brocade M4424 SAN I/O module includes eight external autosensing Fibre Channel ports (four ports are enabled in the standard configuration and four additional ports may be enabled as an optional upgrade), 16 internal ports, and one serial port with an RJ-45 connector. The external Fibre Channel ports operate at 1 Gb/sec, 2 Gb/sec, or 4 Gb/sec. The Fibre Channel switch module is hot-swappable, and may be installed in Fabric B or Fabric C. For general information on installing this module, see "I/O Modules" on page 296.



**NOTE:** The Fibre Channel switch module includes Short Wave Small Form Factor Pluggable (SFP) optical transceivers. To ensure proper functionality, use only SFPs provided with this module.

**Figure 1-42. Brocade M4424 SAN I/O Module Features**



- |   |  |   |   |
|---|--|---|---|
| 1 | Fibre Channel port (8)                 | 2 | Fibre Channel port status indicator (8) |
| 3 | Fibre Channel port speed indicator (8) | 4 | serial port (RJ-45 connector)           |
| 5 | module status indicator                | 6 | status/identification indicator         |
| 7 | power indicator                        |   |   |

**Table 1-24. Brocade M4424 SAN I/O Module Indicators**

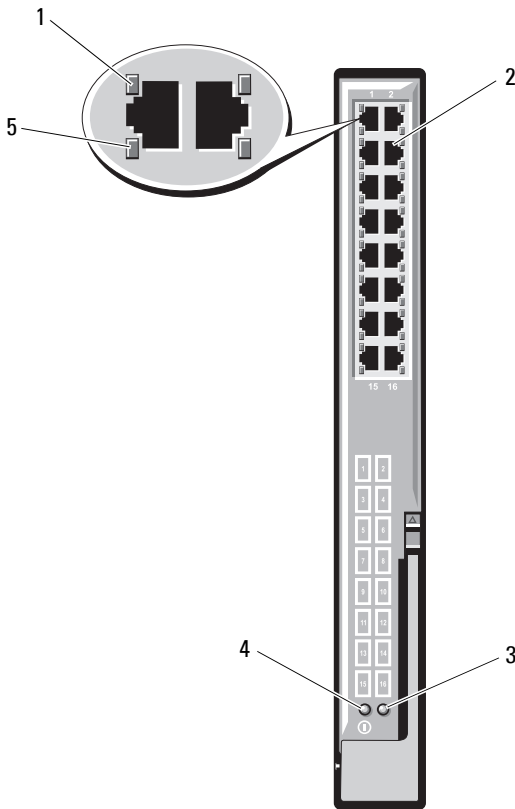
<b>Indicator Type</b>	<b>Pattern</b>	<b>Description</b>
Fibre Channel port status indicator	Off	No signal carrier
	Amber on	Signal present but not online
	Green on	Online, but no activity
	Green blinking slowly	Online but segmented
	Green blinking quickly	Internal loopback
	Green flickering	I/O activity on port
	Amber blinking slowly	Port disabled
Fibre Channel port speed indicator	Amber blinking rapidly	Error or fault with port
	Off	1 Gb link established
	Green on	2 Gb link established
Module status indicator	Amber on	4 Gb link established
	Off	Module is off or enclosure power is off
	Green on	All ports are ready for use
Module power indicator	Amber on	Module is booting being reset, or ports are offline
	Green/amber blinking	Diagnostic message in error log, or environmental range exceeded
	Off	Power to the module is off
Status/identification indicator	Green	Module has power
	Blue on	Primary module in a stack, if applicable
	Blue off	Secondary module in a stack
	Amber flashing	Fault condition in module




## 10/100/1000 Mb Ethernet Pass-Through Module

The Ethernet pass-through module supports 10/100/1000 Mb connections, and provides a direct connection between the optional internal Ethernet mezzanine card in the blade and an external Ethernet device (see Figure 1-43). The Ethernet pass-through modules are hot-swappable, and may be installed in any of the three Fabric. Table 1-25 lists the functionality of the Ethernet pass-through module indicators. For additional information on installing this module, see "I/O Modules" on page 296.

**Figure 1-43. Ethernet Pass-through Module Features**



- |   |                                 |   |                              |
|---|---------------------------------|---|------------------------------|
| 1 | link indicator (16)             | 2 | RJ45 Ethernet connector (16) |
| 3 | status/identification indicator | 4 | power indicator              |
| 5 | activity indicator (16)         |   |                              |

 **NOTE:** Connectors on the Ethernet pass-through module correspond directly to the blade number. For example, blade 5 is connected to port 5 on the Ethernet pass-through module. Integrated network adapter 1 maps to I/O slot A1. Integrated network adapter 2 maps to I/O slot A2.

**Table 1-25. Ethernet Pass-through Module Indicators**

Indicator Type	Pattern	Description
Link indicator/activity indicator	Green on, amber blinking	The Ethernet connector is linked to the blade and there is network activity.
	Green on, amber off	The Ethernet connector is linked to the blade and there is no network activity.
	Green off, amber blinking	The Ethernet connector is not linked to the blade and there is network activity.
	Green off/amber off	The Ethernet connector is not linked to the blade and there is no network activity.
Power indicator	Off	Power to the module is off.
	Green	Module has power.
Status/identification indicator	Blue on	Active module.
	Amber flashing	Fault condition in module.

**NOTE:** Ethernet media speed is configured through the blade LOM firmware or by the operating system. Speed and duplex settings are not configured through the pass-through module itself.

## LCD Status Messages

The following LCD messages refer to events recorded in the System Event Log (SEL). (The messages are shown here in "simple" text format.) For information on the SEL and configuring system management settings, see the systems management software documentation.



**NOTE:** If your system fails to boot, press the System ID button for at least five seconds until an error code appears on the LCD. Record the code, then see "Getting Help" on page 361.

### Viewing Status Messages

If a system error code occurs, the LCD screen turns amber. Press the center (selection) button to view the list of errors or status messages. Use the arrow keys to highlight an error number, and press the center button to view the error.

### Removing LCD Status Messages

For faults associated with sensors, such as temperature, voltage, fans, and so on, the LCD message is automatically removed when that sensor returns to a normal state. For other faults, you must take action to remove the message from the LCD display:

- Clear the SEL — You can perform this task remotely, but you may lose the event history for the system.
- Power cycle — Turn off the system and disconnect it from the electrical outlet; wait approximately ten seconds, reconnect the power cable, and restart the system.

To resolve the problem, refer to the corrective actions in the following table.

**Table 1-26. LCD Status Messages**

Code	Text	Cause	Corrective Actions
E1000	Failsafe voltage error. Contact support.	Check the system event log for critical failure events.	Remove AC power to the system for 10 seconds or clear the SEL.  If the problem persists, see "Getting Help" on page 361.

**Table 1-26. LCD Status Messages (continued)**

<b>Code</b>	<b>Text</b>	<b>Cause</b>	<b>Corrective Actions</b>
E1114	Ambient Temp exceeds allowed range.	Ambient temperature has reached a point outside of the allowed range.	See "Troubleshooting Fan Modules" on page 315.
E1116	Memory disabled, temp above range. Power cycle AC.	Memory has exceeded allowable temperature and has been disabled to prevent damage to the components.	Remove AC power to the system for 10 seconds and restart the system. See "Troubleshooting Fan Modules" on page 315. If the problem persists, see "Getting Help" on page 361.
E1118	CPU temp unavailable. Review SEL. Power cycle AC.	The iDRAC6 is unable to determine the temperature status of the processor(s).	Check the SEL for the E1118 message details. Remove AC power to the system for 10 seconds and restart the system. If the problem persists, see "Getting Help" on page 361.
E1210	Motherboard battery failure. Check battery.	CMOS battery is missing or the voltage is outside of the allowable range.	See "Troubleshooting the NVRAM Backup Battery" on page 324.
E1211	RAID Controller battery failure. Check battery.	RAID battery is either missing, bad, or unable to recharge due to thermal issues.	Reseat the RAID battery connector. See "Installing the Storage Controller Board" on page 282 and "Troubleshooting Fan Modules" on page 315.

**Table 1-26. LCD Status Messages (continued)**

<b>Code</b>	<b>Text</b>	<b>Cause</b>	<b>Corrective Actions</b>
E1229	CPU # VCORE Regulator failure. Reseat CPU.	Specified processor VCORE voltage regulator has failed.	Reseat the processor(s). See "Troubleshooting Processors" on page 322.  If the problem persists, see "Getting Help" on page 361.
E122A	CPU # VTT Regulator failure. Reseat CPU.	Specified processor VTT voltage regulator has failed.	Reseat the processor(s). See "Troubleshooting Processors" on page 322.  If the problem persists, see "Getting Help" on page 361.
E122C	CPU Power Fault. Power cycle AC.	A power fault was detected when powering up the processor(s).	Remove AC power to the system for 10 seconds and restart the system.  If the problem persists, see "Getting Help" on page 361.
E122D	Memory Regulator # Failed. Reseat DIMMs.	One of the memory regulators has failed.	Reseat the memory modules. See "Troubleshooting Blade Memory" on page 319.
E122E	On-board regulator failed. Call support.	One of the on-board voltage regulators failed.	Remove AC power to the system for 10 seconds and restart the system.  If the problem persists, see "Getting Help" on page 361.
E1310	Fan ## RPM exceeding range. Check fan.	Speed of the specified fan is outside of the intended operating range.	See "Troubleshooting Fan Modules" on page 315.

**Table 1-26. LCD Status Messages (continued)**

<b>Code</b>	<b>Text</b>	<b>Cause</b>	<b>Corrective Actions</b>
E1311	Fan module ## RPM exceeding range. Check fan.	Speed of the specified fan in specified module is outside of intended operating range.	See "Troubleshooting Fan Modules" on page 315.
E1313	Fan redundancy lost. Check fans.	The system is no longer fan redundant. Another fan failure would put the system at risk of overheating.	Check LCD for additional scrolling messages. See "Troubleshooting Fan Modules" on page 315.
E1410	Internal Error detected. Check "FRU X".	Specified processor has an internal error. The error may or may not have been caused by the processor.	Remove AC power to the system for 10 seconds and restart the system. If the problem persists, see "Getting Help" on page 361.
E1414	CPU # temp exceeding range. Check CPU heatsink.	Specified processor is out of acceptable temperature range.	Ensure that the processor heat sinks are properly installed. See "Troubleshooting Processors" on page 322 and "Troubleshooting Fan Modules" on page 315.
E1418	CPU # not detected. Check CPU is seated properly.	Specified processor is missing or bad, and the system is in an unsupported configuration.	Ensure that the specified processor is properly installed. See "Troubleshooting Processors" on page 322.
E141C	Unsupported CPU configuration. Check CPU or BIOS revision.	Processors are in an unsupported configuration.	Ensure that your processors match and conform to the type described in the processor technical specifications outlined in your system's <i>Getting Started Guide</i> .

**Table 1-26. LCD Status Messages (continued)**

<b>Code</b>	<b>Text</b>	<b>Cause</b>	<b>Corrective Actions</b>
E141F	CPU # protocol error. Power cycle AC.	The system BIOS has reported a processor protocol error.	Remove AC power to the system for 10 seconds and restart the system.  If the problem persists, see "Getting Help" on page 361.
E1420	CPU Bus parity error. Power cycle AC.	The system BIOS has reported a processor bus parity error.	Remove AC power to the system for 10 seconds or clear the SEL.  If the problem persists, see "Getting Help" on page 361.
E1422	CPU # machine check error. Power cycle AC.	The system BIOS has reported a machine check error.	Remove AC power to the system for 10 seconds and restart the system.  If the problem persists, see "Getting Help" on page 361.
E1610	Power Supply # (### W) missing. Check power supply.	Specified power supply was removed or is missing from the system.	See "Troubleshooting Power Supply Modules" on page 314.
E1614	Power Supply # (### W) error. Check power supply.	Specified power supply has failed.	See "Troubleshooting Power Supply Modules" on page 314.

**Table 1-26. LCD Status Messages (continued)**

<b>Code</b>	<b>Text</b>	<b>Cause</b>	<b>Corrective Actions</b>
E1618	Predictive failure on Power Supply # (### W). Check PSU.	Specified power supply has detected a condition that may predict a future power-down event, such as an over-temperature warning or PSU communication error, that could develop into a fault condition in the power supply.	See "Troubleshooting Power Supply Modules" on page 314.
E161C	Power Supply # (### W) lost AC power. Check PSU cables.	Specified power supply is attached to the system, but it has lost its AC input.	Check the AC power source for the specified power supply. If the problem persists, see "Troubleshooting Power Supply Modules" on page 314.
E1620	Power Supply # (### W) AC power error. Check PSU cables.	Specified power supply's AC input is outside of the allowable range.	Check the AC power source for the specified power supply. If the problem persists, see "Troubleshooting Power Supply Modules" on page 314.
E1624	Lost power supply redundancy. Check PSU cables.	The power supply subsystem is no longer redundant. If the remaining power supply fails, the system shuts down.	See "Troubleshooting Power Supply Modules" on page 314.
E1626	Power Supply Mismatch. PSU1 = ### W, PSU2 = ### W.	The power supplies in the system are not the same wattage.	Ensure that power supplies with matching wattage are installed. See the Technical Specifications outlined in your system's <i>Getting Started Guide</i> .



**Table 1-26. LCD Status Messages (continued)**

<b>Code</b>	<b>Text</b>	<b>Cause</b>	<b>Corrective Actions</b>
E1629	Power required > PSU wattage. Check PSU and config.	The system configuration requires more power than the power supplies can provide, even with throttling.	Turn off power to the system, reduce the hardware configuration or install higher-wattage power supplies, and then restart the system.
E1710	I/O channel check error. Review & clear SEL.	The system BIOS has reported an I/O channel check.	Check the SEL for details of the error message. Remove AC power to the system for 10 seconds and restart the system.  If the problem persists, see "Getting Help" on page 361.
E1714	Unknown error. Review & clear SEL.	The system BIOS has determined there has been an error in the system, but is unable to determine its origin.	Remove AC power to the system for 10 seconds and restart the system.  If the problem persists, see "Getting Help" on page 361.
E1810	Hard drive ## fault. Review & clear SEL.	The SAS subsystem has determined that the specified hard drive has experienced a fault.	See "Troubleshooting Hard Drives" on page 320.
E1812	Hard drive ## removed. Check drive.	The specified hard drive has been removed from the system.	Information only.
E2010	Memory not detected. Inspect DIMMs.	No memory was detected in the system.	Install memory or reset the memory modules. See "Troubleshooting Blade Memory" on page 319.
E2011	Memory configuration failure. Check DIMMs.	Memory detected, but is not configurable. Error detected during memory configuration.	See "Troubleshooting Blade Memory" on page 319.

**Table 1-26. LCD Status Messages (continued)**

<b>Code</b>	<b>Text</b>	<b>Cause</b>	<b>Corrective Actions</b>
E2012	Memory configured but unusable. Check DIMMs.	Memory configured, but is unusable.	See "Troubleshooting Blade Memory" on page 319.
E2013	BIOS unable to shadow memory. Check DIMMs.	The system BIOS failed to copy its flash image into memory.	See "Troubleshooting Blade Memory" on page 319.
E2014	CMOS RAM failure. Power cycle AC.	CMOS failure. CMOS RAM not functioning properly.	Remove AC power to the system for 10 seconds and restart the system. If the problem persists, see "Getting Help" on page 361.
E2015	DMA Controller failure. Power cycle AC.	DMA controller failure.	Remove AC power to the system for 10 seconds and restart the system. If the problem persists, see "Getting Help" on page 361.
E2016	Interrupt Controller failure. Power cycle AC.	Interrupt controller failure.	Remove AC power to the system for 10 seconds and restart the system. If the problem persists, see "Getting Help" on page 361.
E2017	Timer refresh failure. Power cycle AC.	Timer refresh failure.	Remove AC power to the system for 10 seconds and restart the system. If the problem persists, see "Getting Help" on page 361.

**Table 1-26. LCD Status Messages (continued)**

<b>Code</b>	<b>Text</b>	<b>Cause</b>	<b>Corrective Actions</b>
E2018	Programmable Timer error. Power cycle AC.	Programmable interval timer error.	Remove AC power to the system for 10 seconds and restart the system.  If the problem persists, see "Getting Help" on page 361.
E2019	Parity error. Power cycle AC.	Parity error.	Remove AC power to the system for 10 seconds and restart the system.  If the problem persists, see "Getting Help" on page 361.
E201A	SuperIO failure. Power cycle AC.	SIO failure.	Remove AC power to the system for 10 seconds and restart the system.  If the problem persists, see "Getting Help" on page 361.
E201B	Keyboard Controller error. Power cycle AC.	Keyboard controller failure.	Remove AC power to the system for 10 seconds and restart the system.  If the problem persists, see "Getting Help" on page 361.
E201C	SMI initialization failure. Power cycle AC.	System management interrupt (SMI) initialization failure.	Remove AC power to the system for 10 seconds and restart the system.  If the problem persists, see "Getting Help" on page 361.

**Table 1-26. LCD Status Messages (continued)**

<b>Code</b>	<b>Text</b>	<b>Cause</b>	<b>Corrective Actions</b>
E201D	Shutdown test failure. Power cycle AC.	BIOS shutdown test failure.	Remove AC power to the system for 10 seconds and restart the system.  If the problem persists, see "Getting Help" on page 361.
E201E	POST memory test failure. Check DIMMs.	BIOS POST memory test failure.	See "Troubleshooting Blade Memory" on page 319.  If the problem persists, see "Getting Help" on page 361.
E2020	CPU configuration failure. Check screen message.	Processor configuration failure.	Check screen for specific error messages. See "Troubleshooting Processors" on page 322.
E2021	Incorrect memory configuration. Review User Guide.	Incorrect memory configuration.	Check screen for specific error messages (see "Troubleshooting Blade Memory" on page 319).
E2022	General failure during POST. Check screen message.	General failure after video.	Check screen for specific error messages.
E2110	Multibit Error on DIMM ##. Reseat DIMM.	The DIMM in slot "##" has had a multi-bit error (MBE).	See "Troubleshooting Blade Memory" on page 319.

**Table 1-26. LCD Status Messages (continued)**

<b>Code</b>	<b>Text</b>	<b>Cause</b>	<b>Corrective Actions</b>
E2111	SBE log disabled on DIMM ##. Reseat DIMM.	The system BIOS has disabled memory single-bit error (SBE) logging and does not log anymore SBEs until the system is rebooted. "##" represents the DIMM implicated by the BIOS.	Remove AC power to the system for 10 seconds and restart the system.  If the problem persists, see "Troubleshooting Blade Memory" on page 319.
E2112	Memory spared on DIMM ##. Power cycle AC.	The system BIOS has spared the memory because it has determined the memory had too many errors. "##" represents the DIMM implicated by the BIOS.	Remove AC power to the system for 10 seconds and restart the system.  If the problem persists, see "Troubleshooting Blade Memory" on page 319.
E2113	Mem mirror OFF on DIMM ## & ##. Power cycle AC	The system BIOS has disabled memory mirroring because it has determined that half of the mirror has had too many errors. "## & ##" represents the DIMM pair implicated by the BIOS.	Remove AC power to the system for 10 seconds and restart the system.  If the problem persists, see "Troubleshooting Blade Memory" on page 319.
I1911	LCD Log Full. Check SEL to review all Errors.	LCD overflow message. A maximum of ten error messages can display sequentially on the LCD. The eleventh message instructs the user to check the SEL for details on the events.	Check the SEL for details on the events.  Remove AC power to the system for 10 seconds or clear the SEL.
I1912	SEL full. Review & clear log.	The SEL is full of events and is unable to log any more.	Check the SEL for details of the error messages, then remove AC power to the system for 10 seconds to clear the SEL and restart the system.

**Table 1-26. LCD Status Messages (continued)**

<b>Code</b>	<b>Text</b>	<b>Cause</b>	<b>Corrective Actions</b>
W1228	RAID Controller battery capacity < 24hr.	Warns predictively that the RAID battery has less than 24 hours of charge left.	Allow RAID battery to charge to greater than 24 hours of available charge.  If problem persists, replace the RAID battery. See "Installing the Storage Controller Board" on page 282.
W1627	Power required > PSU wattage. Check PSU and config.	The system configuration requires more power than what the power supply can provide.	Turn off power to the system, reduce the hardware configuration or install higher-wattage power supplies, and then restart the system.
W1628	Performance degraded. Check PSU and system configuration.	The system configuration requires more power than what the power supply can provide, but it can boot if throttled.	Turn off power to the system, reduce the hardware configuration or install higher-wattage power supplies, and then restart the system.

**NOTE:** For the full name of an abbreviation or acronym used in this table, see the *Glossary* at [support.dell.com/manuals](http://support.dell.com/manuals).

# System Messages

Table 1-27 lists the system messages that can occur and the probable cause and corrective action for each message.



**CAUTION:** Many repairs may only be done by a certified service technician. You should only perform troubleshooting and simple repairs as authorized in your product documentation, or as directed by the online or telephone service and support team. Damage due to servicing that is not authorized by Dell is not covered by your warranty. Read and follow the safety instructions that came with the product.



**NOTE:** If you receive a system message that is not listed in Table 1-27, check the documentation for the application that is running when the message appears, or the operating system's documentation for an explanation of the message and recommended action.

**Table 1-27. Blade Messages**

Message	Causes	Corrective Actions
Failed to allocate sufficient blade power. Check PCIe card power usage is within limits.	This error occurs when BIOS does not receive a 'Power Granted' status for the blade from iDRAC during POST within a certain timeout period. POST halts when this error occurs.  <b>NOTE:</b> Applicable to M610x only.	A common case that can cause this error is if the PCIe card power allocation specified in the iDRAC GUI is too high and exceeds system limits.
Warning: PCIe expansion riser failed to initialize at maximum link width (x16). Performance will be degraded.	This warning occurs if the PCIe expansion riser initializes at a slower link capacity than the maximum resulting in degraded performance.  <b>NOTE:</b> Applicable to M610x only.	The common cause of this condition is incorrect cabling. See "Expansion Cards and Expansion-Card Riser (PowerEdge M610x Only)" on page 235.

**Table 1-27. Blade Messages (continued)**

<b>Message</b>	<b>Causes</b>	<b>Corrective Actions</b>
Warning: PCIe expansion riser not found. Check mezzanine interface card and cables.	This warning occurs if BIOS does not discover the expansion-card riser during POST. BIOS continues with POST after displaying this warning to the console. <b>NOTE:</b> Applicable to M610x only.	Ensure that the expansion-card riser is installed in the system. If applicable, reinstall the expansion-card riser and check all cable connections. See "Expansion-Card Riser (PowerEdge M610x Only)" on page 239.  If the problem persists, the expansion-card riser may be faulty. See "Getting Help" on page 361.
Error: Unsupported mezzanine card configuration.	This error occurs if the type and configuration of mezzanine cards installed are not supported.	Ensure that the mezzanine cards installed are supported by the blade. See "I/O Module Mezzanine Cards" on page 217.
Verifying blade power...	Status message that BIOS is waiting for iDRAC/CMC to grant power to the blade before proceeding with POST.	Information only.
Cannot Power ON. Cables are not installed properly or Mezz IFC FRU is corrupted	The cables in expansion are not installed properly or Mezz IFC FRU is corrupted. <b>NOTE:</b> Applicable to M610x only.	Ensure that PCIe expansion cables are connected properly. If required, reseal the Mezz IFC FRU. If the problem persists, see "Getting Help" on page 361.
Expansion Cables are not installed properly	PCIe expansion cables not installed properly. <b>NOTE:</b> Applicable to M610x only.	Ensure that PCIe expansion cables are connected properly.



**Table 1-27. Blade Messages (continued)**

<b>Message</b>	<b>Causes</b>	<b>Corrective Actions</b>
Current Overlimit detected in Expansion	Applicable to both base blade and expansion. <b>NOTE:</b> Applicable to M610x only.	Verify that the PCIe expansion cards installed do not have power consumption more than 250 W. For more information, see "Expansion Card Installation Guidelines" on page 235.
Failsafe detected in PCIe expansion on mini planar	Check the system event log for critical failure events. <b>NOTE:</b> Applicable to M610x only.	See "Getting Help" on page 361.
Global PFault detected in Expansion	A PFault has occurred in the expansion. <b>NOTE:</b> Applicable to M610x only.	See "Getting Help" on page 361.
PCIe card inserted in slot X [Vendor ID: YYYY Device ID: ZZZZ]	A new PCIe card has been installed.	For information only.
PCIe card removed from slot X	A PCIe expansion card was removed.	Re-install the expansion card. See "Installing an Expansion Card" on page 236.
Invalid PCIe card found in the Internal Storage slot!	The system halted because an invalid PCIe expansion card is installed in the dedicated storage controller slot.	Remove the PCIe expansion card and install the integrated storage controller in the dedicated slot. See "Storage Controller Card" on page 281.

**Table 1-27. Blade Messages (continued)**

<b>Message</b>	<b>Causes</b>	<b>Corrective Actions</b>
Memory Initialization Warning: Memory size may be reduced	Invalid configuration. The system runs but with less memory than is physically installed.	Ensure that the memory modules are installed in a valid configuration. See "System Memory" on page 171.
Unsupported memory configuration. DIMM mismatch across slots detected:	Invalid memory configuration. DIMMs are mismatched in the specified slots.	Ensure that the memory modules are installed in a valid configuration. See "System Memory" on page 171.
Unsupported DIMM detected. The following DIMM has been disabled:	Invalid memory configuration. The system runs but with the specified DIMM disabled.	Ensure that the memory modules are installed in a valid configuration. See "System Memory" on page 171.
DIMM configuration on each CPU should match	Invalid memory configuration on a dual-processor system. The DIMM configuration for each processor must be identical.	Ensure that the memory modules are installed in a valid configuration. See "System Memory" on page 171.
Maximum rank count exceeded. The following DIMM has been disabled:	Invalid memory configuration. The system runs but with the specified DIMM disabled.	Ensure that the memory modules are installed in a valid configuration. See "System Memory" on page 171.

**Table 1-27. Blade Messages (continued)**

<b>Message</b>	<b>Causes</b>	<b>Corrective Actions</b>
128-Bit Advanced ECC Mode Disabled - For 128-Bit Advanced ECC mode, ECC DIMMs must be used.  DIMMs must be installed in pairs. Pairs must be matched in size and geometry	The memory configuration does not match the setting in BIOS. The BIOS setting has been disabled.	Reconfigure the memory modules to support Advanced ECC mode. See "System Memory" on page 171.
Sparing Mode Disabled - For Sparing mode, matched sets of three must be populated across slots.	The memory configuration does not match the setting in BIOS. The BIOS setting has been disabled.	Reconfigure the memory modules for Memory Sparing mode. See "System Memory" on page 171.
The following DIMM's should match in size:  in rank count:  in size and rank count:  in geometry:  in size and geometry:	Invalid memory configuration. The specified DIMMs do not match in size, number of ranks, or number of data lanes.	Ensure that the memory modules are installed in a valid configuration. See "System Memory" on page 171.
Thermal sensor not detected on	Invalid memory configuration. A mismatched DIMM is installed.	Ensure that the memory modules are installed in a valid configuration. See "System Memory" on page 171.

**Table 1-27. Blade Messages (continued)**

<b>Message</b>	<b>Causes</b>	<b>Corrective Actions</b>
MEMTEST lane failure detected on	Invalid memory configuration. A mismatched DIMM is installed.	Ensure that the memory modules are installed in a valid configuration. See "System Memory" on page 171.
Processors with different power rating detected! System halted	Mismatched processors are installed.	Ensure that all processors have the same cache size, number of cores and logical processors, and power ratings, and that they are properly installed. See "Processors" on page 243.
Processors with different logical processors detected! System halted		
CPUs with different core sizes detected! System halted		
CPU x installed with no memory	Memory modules are required but not installed in the indicated processor's memory slots.	Install memory modules for the processor. See "System Memory" on page 171.
Unused memory detected. DIMM's installed in the following slot are not available when in Mirror or 128-Bit Advanced ECC modes: x, x, x	The memory configuration is not optimal for mirroring or Advanced ECC Memory Mode. Modules in the specified slot(s) are unused.	Reconfigure the memory for Memory Mirroring or Advanced ECC Memory Mode, or change the memory mode to Optimized in the BIOS setup screen. See "System Memory" on page 171.

**Table 1-27. Blade Messages (continued)**

<b>Message</b>	<b>Causes</b>	<b>Corrective Actions</b>
Alert: DIMM_[m] and DIMM_[n] must be populated with a matched set of DIMMs if more than 1 DIMM is present. The following memory DIMMs have been disabled.	The installed memory configuration is invalid.	Ensure that the memory modules are installed in matched pairs. See "System Memory" on page 171.
Alert! Node Interleaving disabled! Memory configuration does not support Node Interleaving.	The installed memory configuration does not support node interleaving.	Install a memory configuration that supports node interleaving. See "System Memory" on page 171.
Alert! Redundant memory disabled! Memory configuration does not support redundant memory.	The installed memory configuration does not support redundant memory.	Install a memory configuration that supports redundant memory. See "System Memory" on page 171. Disable the <b>Redundant Memory</b> option in the System Setup program. See "Using the System Setup Program and UEFI Boot Manager" on page 137.
Alert! Redundancy was previously lost. Power cycle required to reconfigure redundant memory.	Memory error.	Power cycle the blade.

**Table 1-27. Blade Messages (continued)**

<b>Message</b>	<b>Causes</b>	<b>Corrective Actions</b>
Alert! Unsupported memory, incomplete sets, or unmatched sets. The following memory DIMMs have been disabled:l,m,n	The installed memory configuration is invalid.	Add, move, or remove memory modules to achieve a configuration supported by the system. See "System Memory" on page 171.
Caution! NVRAM_CLR jumper is installed on system board.	NVRAM_CLR jumper is set to "on."	Set the NVRAM_CLR jumper to "off." See "Blade System Board Jumper Settings" on page 331 for the jumper location.
CPUs with different cache sizes detected.	Mismatched processors are installed.	Install a correct version of the processor so that both processors have the same cache size. See "Processors" on page 243.
Decreasing available memory.	Faulty or improperly installed memory modules.	Ensure that all memory modules are properly installed. See "Troubleshooting Blade Memory" on page 319.
DIMMs <A1-A8> disabled - SMI channel training failure.	The memory modules are not properly seated.	Reseat or replace Memory Modules. See "System Memory" on page 171.
DIMMs <A1-A8> disabled - Memory Buffer communication error.	The memory module connectors or the processor socket may be exposed to dust. The processor has bent pins.	Ensure that the memory module connectors and processor sockets are clean. Verify that there are no bent pins on the processor. If the processor has bent pins, see "Getting Help" on page 361.

**Table 1-27. Blade Messages (continued)**

<b>Message</b>	<b>Causes</b>	<b>Corrective Actions</b>
DIMMs <A1-A8> disabled - MemBIST error.	The memory modules are not properly seated.	Replace or reseal the memory module(s). See "System Memory" on page 171.  Ensure that the memory module connectors are clean and supported memory modules are installed in a valid configuration. See "General Memory Module Installation Guidelines - PowerEdge M910" on page 179.
DIMMs <A1-A8> disabled - MemBIST timeout.	The memory module connector may be exposed to dust.	
DIMMs <A1-A8> disabled - Rank not found.	Unsupported memory module.	
DIMMs <A1-A8> disabled - DIMM communication error.		
DIMMs <A1-A8> disabled - DDR training error.		
DIMMs <A1-A8> disabled - Simple memory test failure.		
DIMMs <A1-A8> disabled - No memory detected.	The memory modules are not properly seated.  The memory module connectors may be exposed to dust.  Unsupported memory module.	Replace or reseal the memory module(s). See "System Memory" on page 171.  Verify that the memory modules are identical and in a lock-step pair.
DIMMs <A1-A8> disabled - Invalid DIMM.	Unsupported memory modules in the first locked step pair.	See "General Memory Module Installation Guidelines - PowerEdge M910" on page 179.  Replace the memory modules. See "System Memory" on page 171.

**Table 1-27. Blade Messages (continued)**

<b>Message</b>	<b>Causes</b>	<b>Corrective Actions</b>
DIMMs should be installed in pairs. Pairs must be matched in size, speed, and technology.	Mismatched or unmatched DIMMs installed; faulty or improperly installed memory modules. The system operates in a degraded mode with reduced ECC protection. Only memory installed in channel 0 is accessible.	Ensure that all pairs of memory modules are of the same type and size and that they are properly installed. See "System Memory" on page 171. If the problem persists, see "Troubleshooting Blade Memory" on page 319.
DIMMs must be populated in sequential order beginning with slot 1. The following DIMM is electrically isolated: DIMM x.	The specified DIMM is inaccessible to the system due to its location. DIMMs must be populated in sequential order, beginning with slot 1.	Populate two, four, or eight DIMMs sequentially.
DIMM pairs must be matched in size, speed, and technology. The following DIMM pair is mismatched: DIMM [x] and DIMM [y].	Mismatched or unmatched DIMMs installed; faulty or improperly seated memory modules.	Ensure that all pairs of memory modules are of the same type and size, and that they are properly installed. See "System Memory" on page 171 and "Troubleshooting Blade Memory" on page 319.
Diskette read failure.	Faulty or improperly inserted diskette.	Replace the diskette.
Drive not ready.	Diskette missing or improperly inserted in diskette drive.	Reinsert or replace the diskette.



**Table 1-27. Blade Messages (continued)**

<b>Message</b>	<b>Causes</b>	<b>Corrective Actions</b>
Error: Incorrect memory configuration. DIMMs must be installed in pairs of matched memory size, speed, and technology.	Mismatched or unmatched DIMMs installed; faulty or improperly seated memory modules.	Ensure that all pairs of memory modules are of the same type and size, and that they are properly installed. See "System Memory" on page 171. If the problem persists, see "Troubleshooting Blade Memory" on page 319.
Error: Incorrect memory configuration. System halted.	Less than 512 MB of memory installed.	Add memory modules to achieve a configuration supported by the system. See "System Memory" on page 171.
Error: Memory failure detected. Memory size reduced. Replace the faulty DIMM as soon as possible.	Faulty or improperly seated memory modules.	See "Troubleshooting Blade Memory" on page 319.
Error programming flexAddress (MAC) for <i>bus, device, function</i> .	FlexAddress (virtual MAC) is not supported on the specified device.	Information only.
Error programming flexAddress (iSCSI MAC) for <i>bus, device, function</i> .	FlexAddress (virtual MAC) is not supported on the specified device.	Information only.
Error resetting NIC after programming flexAddress for <i>bus, device, function</i> .	FlexAddress (virtual MAC) is not supported on the specified device.	Information only.

**Table 1-27. Blade Messages (continued)**

<b>Message</b>	<b>Causes</b>	<b>Corrective Actions</b>
FBD training error: The following branch has been disabled: Branch x.	The specified branch (channel pair) contains DIMMs that are incompatible with each other.	Ensure that only Dell qualified memory is used. Dell recommends purchasing memory upgrade kits directly from <a href="http://dell.com">dell.com</a> or your Dell sales agent to ensure compatibility.
Gate A20 failure.	Faulty keyboard controller (faulty blade board).	See "Getting Help" on page 361.
General Failure.	Operating system corrupted or improperly installed.	Reinstall the operating system.
HyperTransport error caused a system reset. Please check the system event log for details.	HyperTransport error.	See "Getting Help" on page 361.
Invalid flexAddress for bus, device, function.	FlexAddress (virtual MAC) is not supported on the specified device.	Information only.
Keyboard controller failure.	Faulty keyboard controller (faulty blade board).	See "Getting Help" on page 361.
Keyboard failure.	Loose or improperly connected keyboard cable.	Ensure that the keyboard is properly connected. If the problem persists, replace the keyboard.

**Table 1-27. Blade Messages (continued)**

<b>Message</b>	<b>Causes</b>	<b>Corrective Actions</b>
Error 8602 - Auxiliary Device Failure.  Verify that mouse and keyboard are securely attached to correct connectors.	Mouse or keyboard cable is loose or improperly connected.  Defective mouse or keyboard.	Reseat the mouse or keyboard cable. Ensure that the mouse or keyboard is operational. See "Troubleshooting USB Devices" on page 312.
Manufacturing mode detected.	System is incorrectly configured.	Set the NVRAM_CLR jumper to "on" and reboot the blade. See "Blade System Board Jumper Settings" on page 331 for the jumper location.
Memory address line failure at <i>address</i> , read value expecting <i>value</i> .  Memory double word logic failure at <i>address</i> , read value expecting <i>value</i> .  Memory odd/even logic failure at <i>start address</i> to <i>end address</i> .  Memory write/read failure at <i>address</i> , read value expecting <i>value</i> .	Faulty or improperly installed memory modules, or faulty blade board.	Ensure that all memory modules are properly installed. See "Troubleshooting Blade Memory" on page 319. If the problem persists, see "Getting Help" on page 361.
Memory mirroring enabled.	Memory mirroring enabled.	Information only.

**Table 1-27. Blade Messages (continued)**

<b>Message</b>	<b>Causes</b>	<b>Corrective Actions</b>
Memory tests terminated by keystroke.	The spacebar or ESC key was pressed during POST to terminate the memory test.	Information only.
Keyboard data line failure.	Keyboard cable connector loose or improperly connected. Keyboard or keyboard/mouse controller may be faulty.	Ensure that the keyboard is properly connected. If the problem persists, see "Getting Help" on page 361.
Keyboard stuck key failure.		
Keyboard fuse has failed.	Overcurrent detected in the keyboard connector.	See "Getting Help" on page 361.
No boot device available.	Faulty or missing diskette drive, optical drive, or hard drive.	Check the <b>Integrated Devices</b> configuration settings in the System Setup program and ensure that the controller for the boot device is enabled. See "Using the System Setup Program and UEFI Boot Manager" on page 137. Ensure that the controller for the boot device is enabled.  If the problem persists, replace the drive. See "Hard Drives" on page 267.
No boot sector on hard-disk drive.	An operating system is not on the hard drive.	Check the hard-drive configuration settings in the System Setup program. See "Using the System Setup Program and UEFI Boot Manager" on page 137.
No timer tick interrupt.	Faulty blade board.	See "Getting Help" on page 361.
Not a boot diskette.	Not a bootable diskette.	Use a bootable diskette.

**Table 1-27. Blade Messages (continued)**

<b>Message</b>	<b>Causes</b>	<b>Corrective Actions</b>
PCI BIOS failed to install.	Faulty or improperly installed mezzanine card.	Reseat the mezzanine card. See "I/O Module Mezzanine Cards" on page 217. If the problem persists, see "Getting Help" on page 361.
Plug & Play Configuration Error.	Error encountered in initializing PCI device; faulty blade board.	Set the NVRAM_CLR jumper to "on" and reboot the blade. See "Blade System Board Jumper Settings" on page 331 for the jumper location.  Check for a BIOS update. If the problem persists, see "Getting Help" on page 361.
PCIe Training Error: Expected Link Width is x', Actual Link Width is x	Faulty or improperly installed PCIe card in the specified slot.	Reseat the PCIe card in the specified slot number. See "Troubleshooting Expansion Cards" on page 321. If the problem persists, see "Getting Help" on page 361.
ROM bad checksum = address	Expansion card improperly installed or faulty.	Ensure that the expansion card is installed properly. See "Troubleshooting Expansion Cards" on page 321.
BIOS Update Attempt Failed.	BIOS remote update failed.	Retry the BIOS update. If problem persists, see "Getting Help" on page 361.
Invalid configuration information - please run SETUP program	CMOS checksum failure.	Run the System Setup program and review the current settings. See "Using the System Setup Program and UEFI Boot Manager" on page 137.

**Table 1-27. Blade Messages (continued)**

<b>Message</b>	<b>Causes</b>	<b>Corrective Actions</b>
Read fault.	Faulty diskette, diskette drive, or optical drive.	Replace the diskette. Ensure that the drive cable is properly connected. See "Troubleshooting USB Devices" on page 312 or "Troubleshooting Hard Drives" on page 320 for the appropriate drive(s) installed in your system.
Remote Configuration update attempt failed.	Blade could not implement Remote Configuration request.	Retry Remote Configuration.
Sector not found. Seek error. Seek operation failed.	Faulty diskette or hard drive.	Replace the diskette. If the problem persists, see "Troubleshooting Hard Drives" on page 320 for the appropriate drive installed in your system.
Shutdown failure.	Shutdown test failure.	Ensure that all memory modules are properly installed. See "Troubleshooting Blade Memory" on page 319. If the problem persists, see "Getting Help" on page 361.
Spare bank enabled.	Memory sparing enabled.	Information only.
System service update required.	The iDRAC6 Enterprise Card flash memory may be corrupted.	Restore the flash memory using the latest version on <a href="http://ftp.dell.com">ftp.dell.com</a> or <a href="http://support.dell.com">support.dell.com</a> . See the iDRAC6 User's Guide for instructions on performing a field replacement of the flash memory.

**Table 1-27. Blade Messages (continued)**

<b>Message</b>	<b>Causes</b>	<b>Corrective Actions</b>
The amount of system memory has changed.	Faulty memory module.	See "Troubleshooting Blade Memory" on page 319. If the problem persists, see "Getting Help" on page 361.
This system does not support processors greater than 95W.	Unsupported processor(s) installed.	Replace the processor(s) with a supported version. See "Processors" on page 243.
Time-of-day clock stopped.	Faulty battery; faulty blade board.	See "Troubleshooting Blade Memory" on page 319. If the problem persists, see "Getting Help" on page 361.
Time-of-day not set – please run SETUP program.	Incorrect <b>Time</b> or <b>Date</b> settings; faulty blade board battery.	Check the <b>Time</b> and <b>Date</b> settings. See "Using the System Setup Program and UEFI Boot Manager" on page 137. If the problem persists, see "Troubleshooting the NVRAM Backup Battery" on page 324.
Timer chip counter 2 failed.	Faulty blade board.	See "Getting Help" on page 361.
TPM failure	A Trusted Platform Module (TPM) function has failed.	See "Getting Help" on page 361.

**Table 1-27. Blade Messages (continued)**

<b>Message</b>	<b>Causes</b>	<b>Corrective Actions</b>
TPM configuration operation is pending. Press (I) to Ignore OR (M) to Modify to allow this change and reset the system. WARNING: Modifying could prevent security	This message is displayed when the system re-starts after a TPM configuration command is entered.	Enter I or M to proceed.
TPM configuration operation honored. System will now reset	TPM configuration operation command has been accepted	For information only.
Unsupported CPU combination.	Mismatched processors are installed. Processor is not supported by the blade.	Replace a processor so that both processors match. See "Processors" on page 243. Check for a BIOS update using the Dell Support website at <a href="http://support.dell.com">support.dell.com</a> .
Unsupported CPU stepping detected.	Processor is not supported by the blade.	Check for a BIOS update using the Dell Support website at <a href="http://support.dell.com">support.dell.com</a> . If the problem persists, install a supported processor. See "Processors" on page 243.
CPU set to minimum frequency.	The processor speed may be intentionally set low for power conservation.	If not an intentional setting, check any other system messages for possible causes.



**Table 1-27. Blade Messages (continued)**

<b>Message</b>	<b>Causes</b>	<b>Corrective Actions</b>
Memory set to minimum frequency.	The memory frequency may be intentionally set lower for power conservation.  The current memory configuration may support only the minimum frequency.	If not an intentional setting, check any other system messages for possible causes.  Ensure that your memory configuration supports the higher frequency. See "System Memory" on page 171.
Warning! A fatal error has caused system reset. Please check the event log for details.	Unspecified error.	Check the system event log for information about the error.
Warning! Following faulty DIMMs are disabled: DIMMxx, DIMMyy.	Faulty or improperly seated memory modules.	See "Troubleshooting Blade Memory" on page 319.
Warning! No microcode update loaded for processor <i>n</i> .	Unsupported processor.	Update the BIOS firmware using the Dell Support website at <a href="http://support.dell.com">support.dell.com</a> .
Warning: The current memory configuration is not validated. Change it to the recommended memory configuration or press any key to continue.	There is no memory configuration error, but the memory configuration is not recommended by Dell.	See "System Memory" on page 171.

**Table 1-27. Blade Messages (continued)**

Message	Causes	Corrective Actions
Warning: The current memory configuration is not optimal. For more information on valid memory configurations, please see the Hardware Owner's Manual on the technical support site.	There is no memory configuration error, but the memory configuration is not recommended by Dell.	See "System Memory" on page 171.
Unexpected interrupt in protected mode	Improperly seated DIMMs or faulty keyboard/mouse controller chip.	Reseat the memory modules. See "Troubleshooting Blade Memory" on page 319. If the problem persists, see "Getting Help" on page 361
Write fault. Write fault on selected drive.	Faulty diskette, diskette drive, or optical drive.	Replace the diskette. Ensure that the drive cable is properly connected. See "Troubleshooting USB Devices" on page 312 or "Troubleshooting Hard Drives" on page 320 for the appropriate drive(s) installed in your system.

**NOTE:** For the full name of an abbreviation or acronym used in this table, see the *Glossary* at [support.dell.com/manuals](http://support.dell.com/manuals).

## Warning Messages

A warning message alerts you to a possible problem and prompts you to respond before the system continues a task. For example, before you format a diskette, a message warns you that you may lose all data on the diskette. Warning messages usually interrupt the task and require you to respond by typing y (yes) or n (no).



**NOTE:** Warning messages are generated by either the application or the operating system. For more information, see the documentation that accompanied the operating system or application.

## **Diagnostics Messages**

When you run system diagnostics, an error message may result. Diagnostic error messages are not covered in this section. Record the message on a copy of the Diagnostics Checklist in "Getting Help" on page 361, then follow the instructions in that section for obtaining technical assistance.

## **Alert Messages**

Systems management software generates alert messages for your system. Alert messages include information, status, warning, and failure messages for drive, temperature, fan, and power conditions. For more information, see the systems management software documentation.



# Using the System Setup Program and UEFI Boot Manager

The System Setup program is the BIOS program that enables you to manage your system hardware and specify BIOS-level options. From the System Setup program, you can:

- Change the NVRAM settings after you add or remove hardware
- View the system hardware configuration
- Enable or disable integrated devices
- Set performance and power management thresholds
- Manage system security

## Choosing the System Boot Mode

The System Setup program also enables you to specify the boot mode for installing your operating system:

- BIOS boot mode (the default) is the standard BIOS-level boot interface.
- UEFI boot mode is an enhanced 64-bit boot interface based on Unified Extensible Firmware Interface (UEFI) specifications that overlays the system BIOS. See "Entering the UEFI Boot Manager" on page 150 for more information on this interface.

You select the boot mode in the **Boot Mode** field of the Boot Settings screen of the System Setup program (see "Boot Settings Screen" on page 143). Once you specify the boot mode, the system boots in the specified boot mode and you then proceed to install your operating system from that mode. Thereafter, you must boot the system to the same boot mode (BIOS or UEFI) to access the installed operating system. Trying to boot the operating system from the other boot mode causes the system to halt immediately at start-up.



**NOTE:** Operating systems must be UEFI-compatible (for example, Microsoft Windows Server 2008 x64 version) to be installed from the UEFI boot mode. DOS and 32-bit operating systems do not support UEFI and can only be installed from the BIOS boot mode.

# Entering the System Setup Program

- 1 Turn on or restart your system.
- 2 Press <F2> immediately after you see the following message:

<F2> = System Setup

If your operating system begins to load before you press <F2>, allow the system to finish booting, and then restart your system and try again.

## Responding to Error Messages

If an error message appears while the system is booting, make a note of the message. See "System Messages" on page 115 for an explanation of the message and suggestions for correcting errors.



**NOTE:** After installing a memory upgrade, it is normal for your system to display a message the first time you start your system.

## Using the System Setup Program Navigation Keys

**Table 2-1. System Setup Program Navigation Keys**


Keys	Action
Up arrow or <Shift><Tab>	Moves to the previous field.
Down arrow or <Tab>	Moves to the next field.
Spacebar, <+>, <->, left and right arrows	Cycles through the settings in a field. In some fields, you can also type the appropriate value.
<Esc>	Exits the System Setup program and restarts the system if any changes were made.
<F1>	Displays the System Setup program's help file.




**NOTE:** For most of the options, any changes that you make are recorded but do not take effect until you restart the system.

# System Setup Options

 **NOTE:** The options for the System Setup program change based on the system configuration.

 **NOTE:** The System Setup program defaults are listed under their respective options, where applicable.

Option	Description
System Time	Sets the time on the system's internal clock.
System Date	Sets the date on the system's internal calendar.
Memory Settings	See "Memory Settings Screen" on page 140.
Processor Settings	See "Processor Settings Screen" on page 141.
SATA Settings	See "SATA Settings Screen (PowerEdge M610, M610x)" on page 143.
Boot Settings	See "Boot Settings Screen" on page 143.
Integrated Devices	See "Integrated Devices Screen" on page 144.
PCI IRQ Assignment	Displays a screen to change the IRQ assigned to each of the integrated devices on the PCI bus, and any installed expansion cards that require an IRQ.
Serial Communication	See "Serial Communication Screen" on page 146.
Power Management	See "Power Management Screen (PowerEdge M915, M910, M710, M710HD, M610 and M610x Only)" on page 147.
System Security	See "System Security Screen" on page 148.
Keyboard NumLock (On default)	Determines whether your system starts up with the NumLock mode activated on 101- or 102-key keyboards (does not apply to 84-key keyboards).
Report Keyboard Errors (Report default)	Enables or disables reporting of keyboard errors during the POST. Select <b>Report</b> for host systems that have keyboards attached. Select <b>Do Not Report</b> to suppress all error messages relating to the keyboard or keyboard controller during POST. This setting does not affect the operation of the keyboard itself if a keyboard is attached to the system.

Option	Description
F1/F2 Prompt on Error (Enables default)	<p>Enables the system to halt on errors during POST, which allows the user to observe events that may scroll by unnoticed during normal POST. You can select &lt;F1&gt; to continue or &lt;F2&gt; to enter the System Setup program.</p> <p> <b>CAUTION: When setting this option to Disabled, the system does not halt if an error occurs during POST. Any critical errors are displayed and logged in the system event log.</b></p>

## Memory Settings Screen

Option	Description
System Memory Size	Displays the amount of system memory.
System Memory Type	Displays the type of system memory.
System Memory Speed	Displays the system memory speed.
System Memory Voltage (PowerEdge M915, M710HD)	Displays the current operating voltage of the system memory.
Video Memory	Displays the amount of video memory.
System Memory Testing (Enabled default)	Specifies whether system memory tests are run at system boot. Options are <b>Enabled</b> and <b>Disabled</b> .
Memory Operating Mode (PowerEdge M710, M710HD, M610, and M610x)	This field displays the type of memory operation if a valid memory configuration is installed. When set to <b>Optimizer Mode</b> , the two memory controllers run in parallel 64-bit mode for improved memory performance. When set to <b>Mirror Mode</b> , memory mirroring is enabled. When set to <b>Advanced ECC Mode</b> , the controllers are joined in 128-bit mode running multi-bit advanced ECC.
Memory Optimizer (Enabled default) (PowerEdge M905, M805, and M605)	If set to <b>Disabled</b> , the two DRAM controllers operate in 128-bit mode, and memory reliability is enhanced. If set to <b>Enabled</b> , the memory controllers operate independently in 64-bit mode, and memory performance is optimized.



Option	Description
Redundant Memory (PowerEdge M910, M710HD, and M600)	If a valid memory configuration is installed, you can enable memory mirroring or spare memory. Options are <b>Mirror Mode</b> , <b>Spare Mode</b> , and <b>Disabled</b> .  <b>NOTE:</b> M710HD systems installed with Intel Xeon 5600 series processors support memory sparing.
Redundant Memory (PowerEdge M915, M910, M905, M805, and M605)	If a valid memory configuration is installed, you can enable spare memory. Options are <b>Spare Mode</b> and <b>Disabled</b> .
Node Interleaving ( <b>Disabled</b> default)	If set to <b>Disabled</b> (default), NUMA is employed. If <b>Enabled</b> , memory interleaving is implemented.
Memory Operating Voltage ( <b>Auto</b> default) (PowerEdge M915 and M710HD)	If set to <b>Auto</b> , the system sets the voltage to an optimal value based on the capacity of the installed memory modules. You can also set the voltage of the memory module to a higher value (1.5 V) provided that the modules support multiple voltages.

## Processor Settings Screen

Option	Description
64-bit	Specifies if the processors support 64-bit extensions.
Core Speed	Displays the core speed of the processors.
Bus Speed	Displays the bus speed of the processors.
HyperTransport Technology (M915 only)	This field specifies the HyperTransport I/O link specification supported by the system. If the system board and all the processors support HT 3, this field can be set to HT 3 or HT 1. Else, this is a read-only field and cannot be set to HT 3.
HT Assist (M915 only) ( <b>Disabled</b> default for single-processor systems and <b>Enabled</b> default for multi-processor systems)	If set to <b>Enabled</b> , the system filters broadcast probes to improve HyperTransport I/O link bandwidth and performance on multi-node systems.  <b>NOTE:</b> The probe filter is active only if the system operates with two or more processors and all the processors support probe filter. If only one processor is installed, both nodes must operate at a minimum speed of 1067 MHz.

Option	Description
Logical Processor ( <b>Enabled</b> default)	If set to <b>Enabled</b> , both logical processors per processor core are enabled. If set to <b>Disabled</b> , only one logical processor per core is enabled.
Virtualization Technology ( <b>Disabled</b> default)	<b>NOTE:</b> Disable this feature if your system does not run virtualization software.  Displays when the processors support Virtualization Technology. <b>Enabled</b> permits virtualization software to use Virtualization Technology incorporated in the processor design. This feature can only be used by software that supports Virtualization Technology.
DMA Virtualization (M915 only) ( <b>Disabled</b> default)	If set to enabled, additional hardware capabilities for DMA remapping and virtualization are available.
DRAM Prefetcher (M915 only) ( <b>Enabled</b> default)	Turns on or off the DRAM prefetch unit in the Northbridge.
Adjacent Cache Line Prefetch ( <b>Enabled</b> default)	Enable or disables system optimization for sequential memory access.
Hardware Prefetch Training on Software Prefetch (M915 only) ( <b>Enabled</b> default)	If set to <b>Enabled</b> , the hardware prefetcher includes software prefetches when the system detects strides for prefetch requests.
Hardware Prefetcher ( <b>Enabled</b> default)	Enables or disables the hardware prefetcher.
DCU Streamer Prefetcher ( <b>Enabled</b> default)	Enables or disables DCU streamer prefetcher.
Data Reuse	Enables or disables data reuse in cache.
Execute Disable ( <b>Enabled</b> default)	When set to <b>Enabled</b> , Execute Disable Memory Protection Technology is enabled.
Number of Cores per Processor ( <b>All</b> default)	If set to <b>All</b> , all cores in each processor are enabled.

Option	Description
Intel<R> QPI Bandwidth Priority	Sets the bandwidth priority to compute.
Turbo Mode	If supported by the processor(s), enables or disables <b>Turbo Mode</b> .
C1E (M915 only)	When set to <b>Enabled</b> , the processor switches to minimum performance in the idle state.
C States ( <b>Enabled</b> default)	When set to <b>Enabled</b> , the processor(s) can operate in all power states.
Processor X Family-Model-Stepping	Displays the family and model number of each processor. A submenu displays the core speed, the amount of cache memory, and the number of cores of the processor(s).

## SATA Settings Screen (PowerEdge M610, M610x)

Option	Description
Embedded SATA (ATA Mode default)	<b>ATA Mode</b> enables the integrated SATA controller. <b>Off</b> disables the controller.
Port A (Auto default)	<b>Auto</b> enables BIOS support for the device attached to SATA port A. <b>Off</b> disables BIOS support for the device.
Port B (Auto default)	<b>Auto</b> enables BIOS support for the device attached to SATA port B. <b>Off</b> disables BIOS support for the device.

## Boot Settings Screen

Option	Description
Boot Mode (BIOS default) (PowerEdge M915, M910, M710, M710HD, M610, and M610x)	If the operating system supports Unified Extensible Firmware Interface, set this option to UEFI. Setting this field to <b>BIOS</b> allows compatibility with non-UEFI operating systems.  <b>NOTE:</b> Setting this field to <b>UEFI</b> disables the <b>Boot Sequence</b> , <b>Hard-Disk Drive Sequence</b> , and <b>USB Flash Drive Emulation Type</b> fields.

<b>Option</b>	<b>Description</b>
Boot Sequence	If <b>Boot Mode</b> is set to <b>BIOS</b> , this field tells the system where the operating system files needed for startup are located. If <b>Boot Mode</b> is set to <b>UEFI</b> , you can access the UEFI boot manager utility by rebooting the system and pressing F11 when prompted to do so.
Hard-Disk Drive Sequence	Determines the order in which the BIOS attempts to boot from hard drives in the system during system startup.
USB Flash Drive Emulation Type ( <b>Auto</b> default)	Determines the emulation type for a USB flash drive. <b>Hard disk</b> allows the USB flash drive to act as a hard drive. <b>Floppy</b> allows the USB flash drive to act as a removable diskette drive. <b>Auto</b> automatically chooses an emulation type.
Boot Sequence Retry ( <b>Disabled</b> default)	If this field is enabled and the system has failed to boot, the system reattempts to boot after 30 seconds.

## Integrated Devices Screen

<b>Option</b>	<b>Description</b>
Integrated SAS Controller <i>or</i> Integrated RAID controller ( <b>Enabled</b> default.)	Enables the integrated SAS or RAID controller.
User Accessible USB Ports ( <b>All Ports On</b> default)	Enables or disables the system's USB ports. Options are <b>All Ports On</b> or <b>All Ports Off</b> .
Internal USB Port (PowerEdge M915, M910, M710, M710HD, M610, and M610x)	Enables or disables the system's internal USB port.

Option	Description
Internal SD Card Port (PowerEdge M915, M910, M905, M805, M710, M710HD, M610 and M610x)	Enables or disables the system's internal SD card port. <b>NOTE:</b> If a hypervisor is installed, it uses this port.
Redundancy (Disabled default) (M915, M910 and M710HD)	Enables or disables the mirror mode for Internal Dual SD Module (IDSMD). <b>NOTE:</b> When set to <b>Mirror Mode</b> , the vFlash functionality of the iDRAC 6 card is not available and the card is set as the secondary SD card (SD2) in IDSMD.
Embedded NIC <sub>n</sub> and NIC <sub>n</sub>	Enables or disables integrated NIC1 and NIC2. Changes take effect after the system reboots.
Embedded Gb NIC <sub>x</sub> (Enabled with PXE default)	Enables or disables the system's integrated Gb NICs. Options are <b>Enabled</b> , <b>Enabled with PXE</b> , <b>Enabled with iSCSI Boot</b> , and <b>Disabled</b> . PXE support allows the system to boot from the network. Changes take effect after the system reboots.
Embedded NIC1 and NIC2 (Enabled default)	Enables or disables the system's embedded NIC1 and NIC2 controller. <b>NOTE:</b> For M710HD, you can enable or disable the NIC1/NIC2 and NIC3/NIC4 controllers.
MAC Address	Displays the MAC address for a particular integrated NIC. This field does not have user-selectable settings.
iSCSI MAC Address	Displays the iSCSI MAC address for a particular integrated NIC if <b>Enabled with iSCSI Boot</b> is enabled. This field does not have user-selectable settings.
Capability Detected	Displays the features provided by the hardware key installed in the NIC hardware key socket on the system board. <b>NOTE:</b> Some features may require the installation of an additional driver.

Option	Description
OS Watchdog Timer (Disabled default).	If set to <b>Enabled</b> , the operating system restarts the system if it locks up, based on the expiration of a timer. If set to <b>Disabled</b> , in the event of a system lockup, no timer is set and the OS does not restart the system in the event of a lockup.
I/OAT DMA Engine (Disabled default) (PowerEdge M910, M710, M610x, M610, M600)	If set to <b>Enabled</b> , the I/O Acceleration Technology feature is enabled for network controllers that support this technology.
Embedded Video Controller ( <b>Enabled</b> default)	This option should always be set to <b>Enabled</b> .
SR-IOV-Global Enable (PowerEdge M915 only) (Disabled default)	Enables/disables BIOS configuration of Single Root I/O Virtualization (SR-IOV) devices.

## PCI IRQ Assignments Screen

Option	Description
<PCIe device>	Use the <+> and <-> keys to manually select an <u>IRQ</u> for a given device, or select <b>Default</b> to allow the BIOS to select an <u>IRQ</u> value at system start-up.

## Serial Communication Screen

The blade has a single serial port (COM1) which can be enabled for console redirection through the IMC.

Option	Description
Serial Communication (Off default)	Options are <b>On with Console Redirection</b> , <b>On without Console Redirection</b> , and <b>Off</b> .
Serial Port Address (COM1 default)	Sets the serial port addresses to <b>COM1</b> or <b>COM2</b> .

<b>Option</b>	<b>Description</b>
Failsafe Baud Rate (115200 default)	Displays the failsafe baud rate used for console redirection when the baud rate cannot be negotiated automatically with the remote terminal.
Remote Terminal Type (VT 100/VT 220 default)	Select either VT 100/VT 220 or ANSI.
Redirection After Boot (Enabled default)	Enables or disables BIOS console redirection after your system boots to the operating system.

### **Power Management Screen (PowerEdge M915, M910, M710, M710HD, M610 and M610x Only)**

<b>Option</b>	<b>Description</b>
Power Management	Options are OS Control, Active Power Controller, Custom, or Maximum Performance.  If you select OS Control, Active Power Controller, or Static Management Performance, the BIOS preconfigures the remaining options on this screen. If you select Custom, you can configure each option independently.
CPU Power and Performance Management	Options are OS DBPM, System DBPM, Maximum Performance, or Minimum Power.
Fan Power and Performance Management	Options are Maximum Performance or Minimum Power.
Memory Power and Performance Management	Options are Maximum Performance, a specified frequency, or Minimum Performance.

## System Security Screen

Option	Description
System Password	<p>Displays the current status of the password security feature and allows a new system password assignment and verification.</p> <p><b>NOTE:</b> For more information, see "Using the System Password" on page 151.</p>
Setup Password	<p>Restricts access to the System Setup program by using a setup password.</p> <p><b>NOTE:</b> For more information, see "Using the System Password" on page 151.</p>
Password Status (Unlocked default)	<p>When <b>Setup Password</b> is assigned and this field is <b>Locked</b>, the system password cannot be changed or disabled at system start-up.</p> <p><b>NOTE:</b> For more information, see "Using the System Password" on page 151.</p>
TPM Security (Off default)	<p>Sets the reporting of the Trusted Platform Module (TPM) in the system.</p> <p>If <b>Off</b>, the presence of the TPM is not reported to the operating system.</p> <p>If <b>On with Pre-boot Measurements</b>, the system reports the TPM to the operating system and stores the pre-boot measurements to the TPM during POST.</p> <p>If <b>On without Pre-boot Measurements</b>, the system reports the TPM to the operating system and bypasses pre-boot measurements.</p>
TPM Activation (No Change default)	<p>When set to <b>Activate</b>, the TPM is enabled to default settings. When set to <b>Deactivate</b>, the TPM is disabled. The <b>No Change</b> state initiates no action. The operational state of the TPM remains unchanged (all user settings for the TPM are preserved).</p> <p><b>NOTE:</b> This field is read-only when <b>TPM Security</b> is set to <b>Off</b>.</p>



Option	Description
TPM Clear (No default)	<p><b>NOTE:</b> Clearing the TPM loses all encryption keys in the TPM. This option prevents booting to the operating system and results in data loss if the encryption keys cannot be restored. Back up the TPM keys prior to enabling this option.</p> <p>When set to <b>Yes</b>, all TPM contents are cleared.</p> <p><b>NOTE:</b> This field is read-only when <b>TPM Security</b> is set to <b>Off</b>.</p>
Power Button (Enabled default)	<p>If <b>Enabled</b>, the power button can turn the system's power off and on. On an ACPI-compliant operating system, the system performs an orderly shutdown before power is turned off.</p> <p>When <b>Disabled</b>, the button can only turn on system power.</p> <p><b>NOTE:</b> You can still turn on the system by using the power button, even if the <b>Power Button</b> option is set to <b>Disabled</b>.</p>
AC Power Recovery (Last default)	<p>Determines how the system reacts when power is restored. If set to <b>Last</b>, the system returns to the last power state. <b>On</b> turns on the system after power is restored. <b>Off</b> allows the system to remain off after power is restored.</p>

## Exit Screen

After you press <Esc> to exit the System Setup program, the **Exit** screen displays the following options:

- Save Changes and Exit
- Discard Changes and Exit
- Return to Setup

# Entering the UEFI Boot Manager

- 1 Turn on or restart your system.
- 2 Press <F11> after you see the following message:

<F11> = UEFI Boot Manager



**NOTE:** The system does not respond until the USB keyboard is active.



**NOTE:** The Boot Mode option in System Setup must be set to UEFI to access the UEFI Boot Manager.

If your operating system begins to load before you press <F11>, allow the system to finish booting, and then restart your system and try again.

## UEFI Boot Manager Screen

Option	Description
Continue	Selecting this option executes the current boot options in listed order.
<Boot options>	The list of current boot options is displayed, with an asterisk. Select the boot option you wish to use and press <Enter>.
UEFI Boot Settings	Enables you to add, delete, enable, disable, and change boot options, or execute a one-time boot option.
System Utilities	Enables you to access the legacy System Setup program, System Services, and BIOS-level boot options.

## UEFI Boot Settings Screen

Option	Description
Add Boot Option	Adds a new boot option.
Delete Boot Option	Deletes an existing boot option.
Enable/Disable Boot Option	Disables and enables a boot option in the boot option list.
Change Boot Option	Changes the order of the boot option list.
One-Time Boot From File	Sets a one-time boot option not included in the boot option list.

## System Utilities Screen

Option	Description
System Setup	Accesses the System Setup program without rebooting.
System Services	Restarts the system and accesses the Unified Server Configurator, which allows you to run utilities such as system diagnostics. For more information, see the <i>Unified Server Configurator User's Guide</i> .
BIOS Boot Manager	Accesses the BIOS-level boot options list without rebooting.
Reboot System	Restarts the system.

## System and Setup Password Features

Your system is shipped without the system password feature enabled. Operate the system only with system password protection.



**NOTE:** The password features provide a basic level of security for the data on your system.



**NOTE:** Anyone can access the data stored on your system if the system is running and unattended.

### Using the System Password

When a system password is assigned, the system prompts for the system password after the system starts and only those with the password have full use of the system.

#### Assigning a System Password

Before assigning a system password, enter the System Setup program and check the **System Password** option.

When a system password is assigned, **System Password is Enabled**. If **Password Status is Unlocked**, you can change the system password. If **Locked**, you cannot change the system password. Disabling the password jumper on the system board sets **System Password** to **Disabled**, and you cannot change or enter a new system password.


When a system password is not assigned and the password jumper on the system board is in the enabled position, **System Password** is **Not Enabled** and **Password Status** is **Unlocked**. To assign a system password:

- 1 Verify that **Password Status** is **Unlocked**.
- 2 Highlight the **System Password** option and press <Enter>.
- 3 Type your new system password.


You can use up to 32 characters in your password.

As you type, placeholders appear in the field.


The password assignment is not case-sensitive. Certain key combinations are invalid and if you enter one, the system beeps. To erase a character, press <Backspace> or the left-arrow key.

 **NOTE:** To escape from the field without assigning a system password, press <Enter> to move to another field, or press <Esc> prior to completing step 5.

- 4 Press <Enter>.
- 5 To confirm your password, type it a second time and press <Enter>. **System Password** changes to **Enabled**. Exit the System Setup program and begin using your system.
- 6 Either reboot the system now for the password protection to take effect or continue working.

 **NOTE:** Password protection does not take effect until the system reboots.

### Using Your System Password to Secure Your System

 **NOTE:** If you have assigned a setup password (see "Using the Setup Password" on page 153), the system accepts your setup password as an alternate system password.

When **Password Status** is **Unlocked**, you have the option to leave the password security enabled or to disable password security.

To leave the password security enabled:

- 1 Turn on or reboot your system by pressing <Ctrl><Alt><Del>.
- 2 Type your password and press <Enter>.

To disable the password security:

- 1 Turn on or reboot your system by pressing <Ctrl><Alt><Del>.
- 2 Type your password and press <Ctrl><Enter>.

When **Password Status** is **Locked**, you must type the password and press <Enter> when prompted at reboot.

If an incorrect system password is entered, the system displays a message and prompts you to re-enter your password. You have three attempts to enter the correct password. After the third unsuccessful attempt, the system displays an error message that the system has halted and the system shuts down.

Even after you shut down and restart the system, the error message continues to be displayed until the correct password is entered.



**NOTE:** You can use the **Password Status** option in conjunction with the **System Password** and **Setup Password** options to protect your system from unauthorized changes.

### Changing an Existing System Password

- 1 Enter the System Setup program by pressing <F2> during POST.
- 2 Select the System Security screen.
- 3 Verify that the **Password Status** is **Unlocked**.
- 4 Type the new system password in the two password fields.

The **System Password** field changes to **Not Enabled** if the password was deleted.

### Using the Setup Password

#### Assigning a Setup Password

You can assign a setup password only when the **Setup Password** is **Not Enabled**. To assign a setup password, highlight the **Setup Password** option and press the <+> or <-> key. The system prompts you to enter and verify the password.



**NOTE:** The setup password can be the same as the system password. If the two passwords are different, the setup password can be used as an alternate system password. The system password cannot be used in place of the setup password.

You can use up to 32 characters in your password.

As you type, placeholders appear in the field.

The password assignment is not case-sensitive. Certain key combinations are invalid and if you enter one, the system beeps. To erase a character, press <Backspace> or the left-arrow key.

When you verify the password, the **Setup Password** changes to **Enabled**. The next time you enter the System Setup program, the system prompts you for the setup password.

A change to the **Setup Password** option becomes effective immediately (restarting the system is not required).

### **Operating With a Setup Password Enabled**

If **Setup Password** is **Enabled**, you must enter the correct setup password before modifying most of the System Setup options.

If you do not enter the correct password in three attempts, the system lets you view, but not modify, the System Setup screens. The following options are exceptions: If **System Password** is not **Enabled** and is not locked through the **Password Status** option, you can assign a system password. You cannot disable or change an existing system password.



**NOTE:** You can use the **Password Status** option in conjunction with the **Setup Password** option to protect the system password from unauthorized changes.

### **Deleting or Changing an Existing Setup Password**

- 1 Enter the System Setup program and select the **System Security**.
- 2 Highlight **Setup Password**, press <Enter> to access the setup password window. Press <Enter> twice to clear the existing setup password.  
The setting changes to **Not Enabled**.
- 3 If you want to assign a new setup password, perform the steps in "Assigning a Setup Password" on page 153.

# Installing Blade Components

## Recommended Tools

You may need the following items to perform the procedures in this section:

- #1 and #2 Phillips screwdrivers
- T8 and T10 Torx drivers
- Wrist grounding strap

## Removing and Installing a Blade

### Removing a Blade

- 1 Power down the blade using OS commands or the CMC, and ensure that the blade's power is off.

When a blade is powered off, its front-panel power indicator is off. See Figure 1-13.

- 2 Before removing full-height blades 3 or 4 or half-height blades 11 or 12, rotate the LCD panel to the storage position to prevent accidental damage to the LCD screen.
- 3 Press the release button on the handle. See Figure 3-1 or Figure 3-2.
- 4 Pull out the handle to unlock the blade from the enclosure.
- 5 Slide the blade out of the enclosure.
- 6 Install the I/O connector cover over the I/O connector.

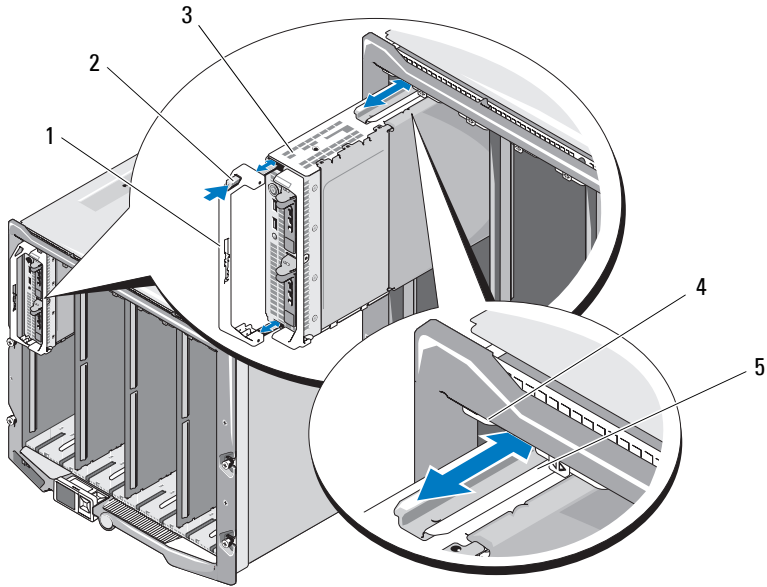


**CAUTION:** To protect the I/O connector pins, install the I/O connector cover any time a blade is removed from the enclosure. (A full-height blade requires two connector covers.)



**CAUTION:** If you are permanently removing the blade, install a blade blank. (A full-height blade requires two blade blanks.) Operating the system for extended periods of time without a blade blank installed can cause the enclosure to overheat. See "Installing a Blade Blank" on page 159.

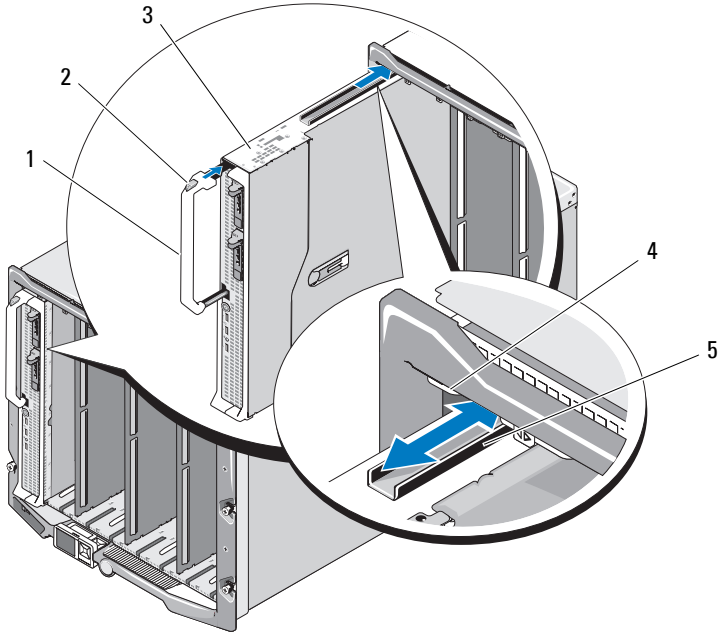
**Figure 3-1. Removing and Installing a Half-Height Blade**



- |   |                                      |   |                                |
|---|--------------------------------------|---|--------------------------------|
| 1 | blade handle                         | 2 | release button                 |
| 3 | blade                                | 4 | guide rail on M1000e enclosure |
| 5 | guide rail on blade (or blade blank) |   |                                |



**Figure 3-2. Removing and Installing a Full-Height Blade**



- 1 blade handle
- 3 blade
- 5 guide rail on blade

- 2 release button
- 4 guide rail on M1000e enclosure

## Installing a Blade

- 1 If you are installing a new blade, remove the plastic cover from the I/O connector(s) and save for future use. See Figure 3-3.
- 2 Orient the blade so that the handle is on the left side of the blade.
- 3 If you are installing a blade in one of the eight upper bays, align the guide rail on the upper edge of the blade so that the rail fits between the plastic guides on the enclosure.

If you are installing a half-height blade in one of the eight lower bays, align the edge of the blade with the guide rail on the floor of the M1000e enclosure.

If you are installing a full-height blade in bays 1 or 2 or a half-height blade in bays 12 or 13, rotate the LCD module to the horizontal storage position to prevent accidental damage to the LCD screen.

- 4 Slide the blade into the enclosure until the handle engages and locks the blade in place.

## Removing and Installing a Blade Blank



**CAUTION: If you are permanently removing the blade, install a blade blank. (A full-height blade requires two blade blanks.) Operating the system for extended periods of time without a blade blank installed can cause the enclosure to overheat. See "Installing a Blade Blank" on page 159.**

### Removing a Blade Blank

*If you are removing a blade blank from one of the eight upper bays, press the blue latch at the upper edge of the blank faceplate and slide the blank out of the enclosure.*

*If you are removing a blade blank from one of the eight lower bays, press the blue latch at the lower edge of the blank faceplate, and slide the blank out of the enclosure.*

## Installing a Blade Blank

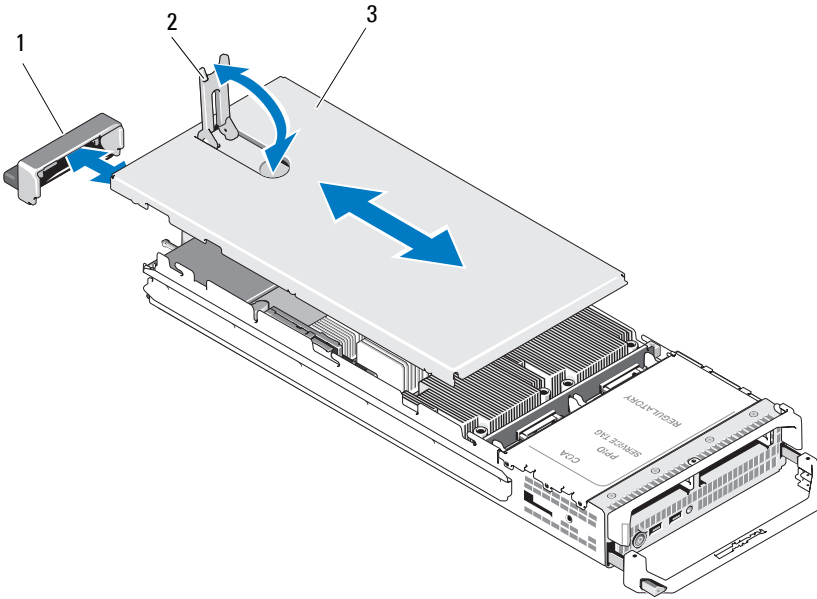
- 1 Hold the blank with the guide rail facing upwards (see detail in Figure 3-1).
- 2 Install the blank in the enclosure:
  - *If you are installing a blade blank in one of the eight upper bays, align the metal guide rail on the upper edge of the blade blank so that the guide rail fits between the plastic guides on the enclosure (see detail in Figure 3-1).*
  - *If you are installing a blade blank in one of the eight lower bays, align the edge of the blank with the plastic guide rail on the floor of the M1000e enclosure, and slide the blank into the enclosure until the lower latch engages.*

## Opening and Closing the Blade

### Opening the Blade

- 1 Remove the blade from the enclosure. See "Removing a Blade" on page 155.
- 2 Install the I/O connector cover(s). See Figure 3-3.  
A full-height blade requires two connector covers.
- 3 Orient the blade as shown in Figure 3-3 so that the cover-release latch faces up.
- 4 Lift the cover-release latch and slide the cover toward the back of the blade until it stops.
- 5 Carefully lift the cover away from the blade.

**Figure 3-3. Opening a Blade (PowerEdge M600 Shown)**



1 I/O connector cover

2 cover-release latch

3 chassis cover

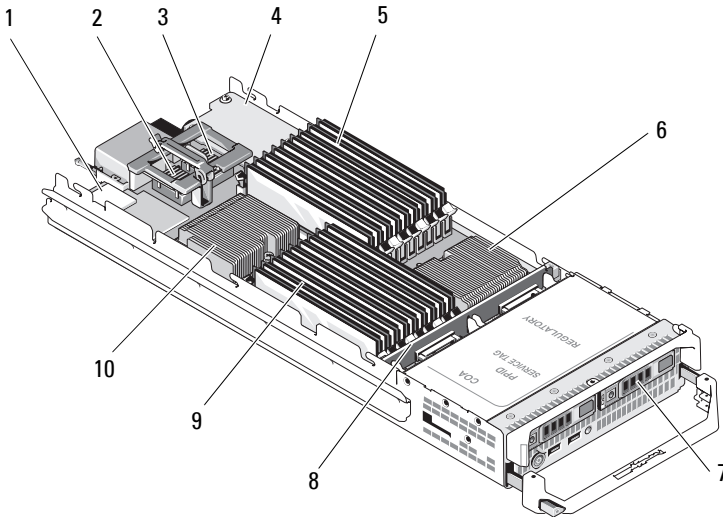
## **Closing the Blade**

- 1** Ensure that no tools or parts are left inside the blade.
- 2** Align the notches in the edges of the enclosure with the cover alignment pins on the inner sides of the cover.
- 3** Check that these cover-release latch is fully open, and lower the cover onto the enclosure.
- 4** Close the cover-release latch until it is flush with the surface of the cover.

# Inside the System

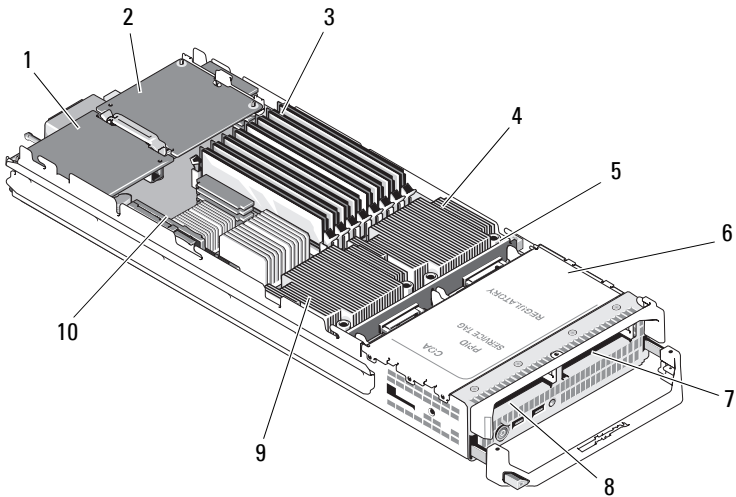
Figure 3-4 through Figure 3-12 show the interior components in the blades.

**Figure 3-4. Inside a Half-Height Blade (PowerEdge M710HD)**



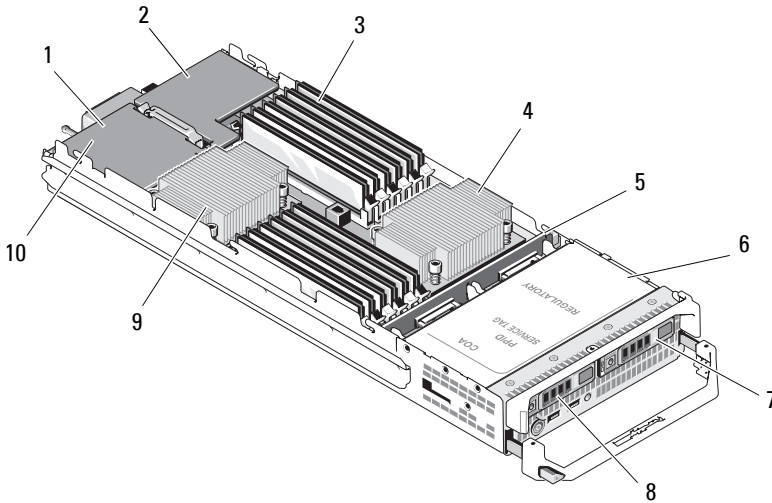
- |   |                                      |    |                                      |
|---|--------------------------------------|----|--------------------------------------|
| 1 | iDRAC6 enterprise card               | 2  | optional mezzanine card 1 - Fabric C |
| 3 | optional mezzanine card 2 - Fabric B | 4  | network daughter card                |
| 5 | memory modules (A1 to A9)            | 6  | processor CPU2 and heat sink         |
| 7 | hard drives (2)                      | 8  | hard-drive backplane                 |
| 9 | memory modules (B1 to B9)            | 10 | processor CPU1 and heat sink         |

**Figure 3-5. Inside a Half-Height Blade (PowerEdge M600)**



- |   |                                  |    |  |
|---|----------------------------------|----|--|
| 1 | optional Fabric C mezzanine card | 2  | optional Fabric B mezzanine card           |
| 3 | memory modules                   | 4  | processor CPU1 and heat sink               |
| 5 | hard-drive backplane             | 6  | storage controller card (under drive bays) |
| 7 | hard drive 1                     | 8  | hard drive 0                               |
| 9 | processor CPU2 and heat sink     | 10 | video riser card                           |

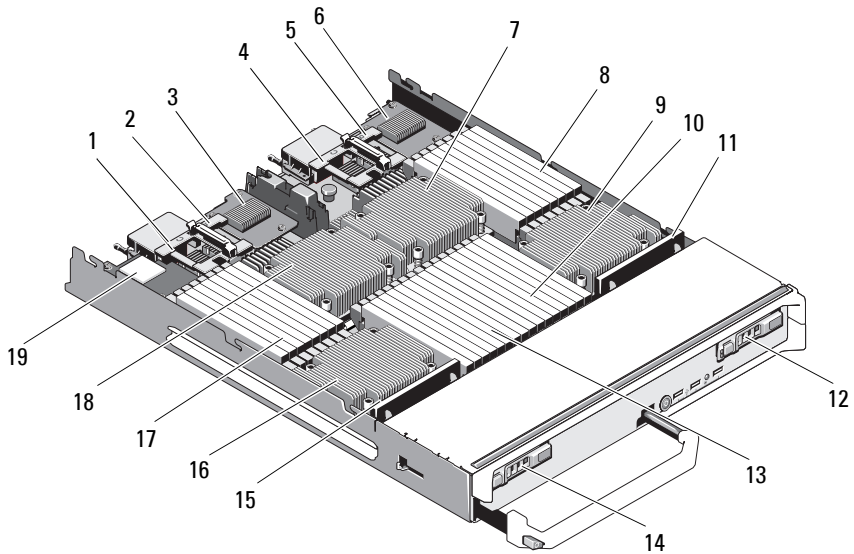
**Figure 3-6. Inside a Half-Height Blade (PowerEdge M610)**



- |   |  |    |  |
|---|--|----|--|
| 1 | optional mezzanine card<br>Mezz3_Fab_C | 2  | optional mezzanine card -<br>Mezz4_Fab_B         |
| 3 | memory modules                         | 4  | processor CPU2 and heat sink                     |
| 5 | hard-drive backplane                   | 6  | storage controller card (under<br>drive bays)    |
| 7 | hard drive 1                           | 8  | hard drive 0                                     |
| 9 | processor CPU1 and heat sink           | 10 | iDRAC6 Enterprise card (under<br>mezzanine card) |

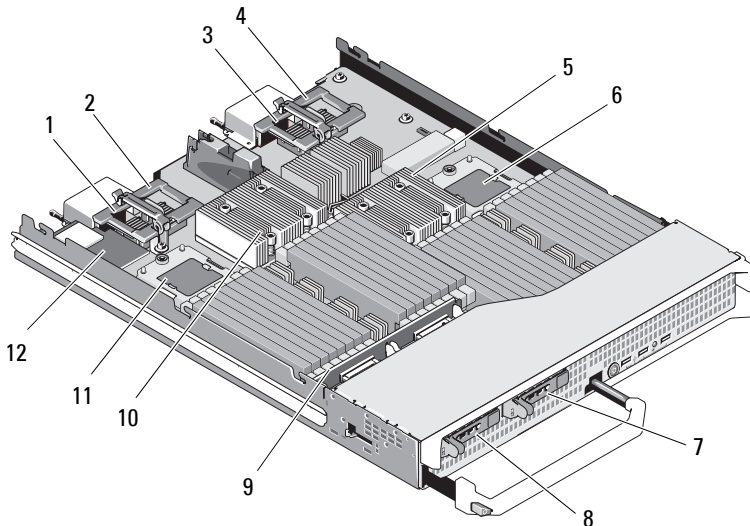


**Figure 3-7. Inside a Full-Height Blade (PowerEdge M915)**



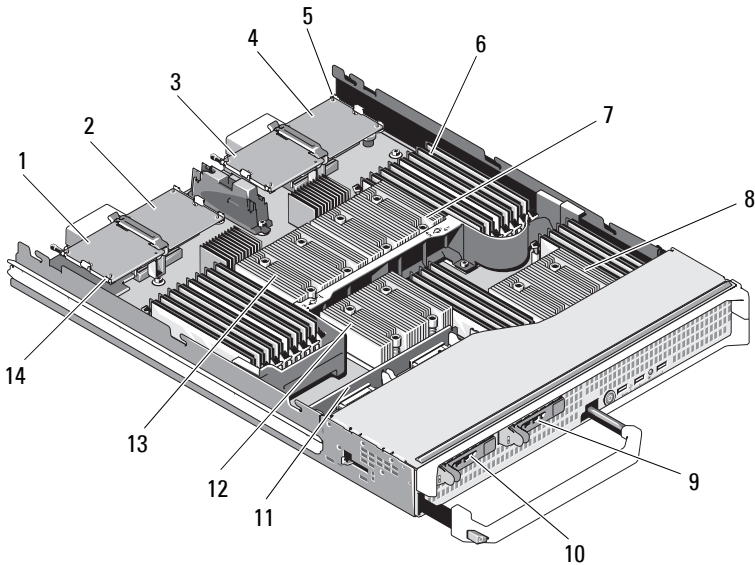
- |    |  |    |  |
|----|--|----|--|
| 1  | optional mezzanine card<br>Mezz1_Fab_C   | 2  | optional mezzanine card -<br>Mezz2_Fab_B |
| 3  | LOM Riser A                              | 4  | optional mezzanine card<br>Mezz3_Fab_C   |
| 5  | optional mezzanine card -<br>Mezz4_Fab_B | 6  | LOM Riser B                              |
| 7  | processor CPU2 and heat sink             | 8  | memory modules<br>(for CPU 2)            |
| 9  | processor CPU4 and heat sink             | 10 | memory modules<br>(for CPU 4)            |
| 11 | hard-drive backplane 2                   | 12 | hard-drive 1                             |
| 13 | memory modules<br>(for CPU 3)            | 14 | hard-drive 0                             |
| 15 | hard-drive backplane 1                   | 16 | processor CPU3 and heat sink             |
| 17 | memory modules<br>(for CPU 1)            | 18 | processor CPU1 and heat sink             |
| 19 | iDRAC6 enterprise card                   |    |  |

**Figure 3-8. Inside a Full-Height Blade (PowerEdge M910)**



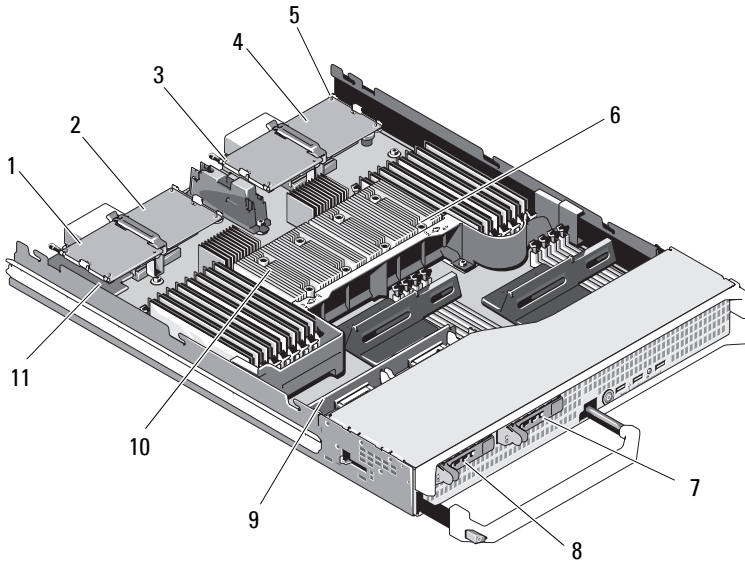
- |    |                                      |    |                                      |
|----|--------------------------------------|----|--------------------------------------|
| 1  | optional mezzanine card 1 - Fabric C | 2  | optional mezzanine card 2 - Fabric B |
| 3  | optional mezzanine card 3 - Fabric C | 4  | optional mezzanine card 4 - Fabric B |
| 5  | processor CPU2 and heat sink         | 6  | processor CPU4                       |
| 7  | hard drive 1                         | 8  | hard drive 0                         |
| 9  | hard-drive backplane                 | 10 | processor CPU1 and heat sink         |
| 11 | processor CPU3                       | 12 | iDRAC6 Enterprise card               |

**Figure 3-9. Inside a Full-Height Blade (PowerEdge M905)**



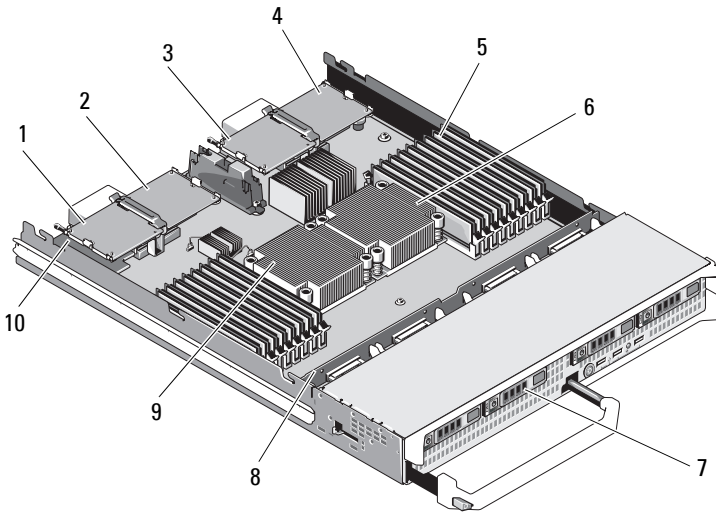
- |    |                                      |    |                                      |
|----|--------------------------------------|----|--------------------------------------|
| 1  | optional mezzanine card 1 - Fabric C | 2  | optional mezzanine card 2 - Fabric B |
| 3  | optional mezzanine card 3 - Fabric C | 4  | optional mezzanine card 4 - Fabric B |
| 5  | SD card location                     | 6  | memory modules                       |
| 7  | processor CPU2 and heat sink         | 8  | processor CPU4 and heat sink         |
| 9  | hard drive 1                         | 10 | hard drive 0                         |
| 11 | hard-drive backplane                 | 12 | processor CPU3 and heat sink         |
| 13 | processor CPU1 and heat sink         | 14 | video riser card                     |

**Figure 3-10. Inside a Full-Height Blade (PowerEdge M805)**



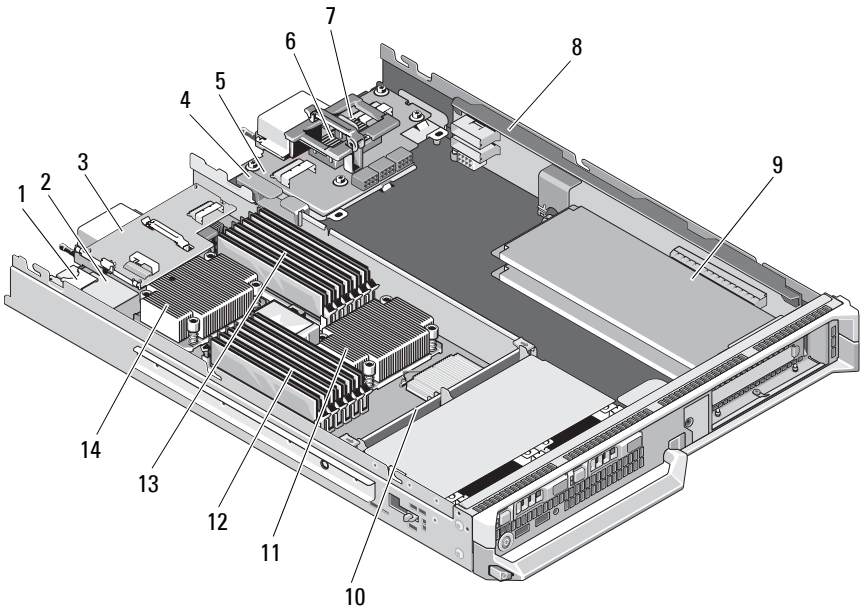
- |    |                                      |    |                                      |
|----|--------------------------------------|----|--------------------------------------|
| 1  | optional mezzanine card 1 - Fabric C | 2  | optional mezzanine card 2 - Fabric B |
| 3  | optional mezzanine card 3 - Fabric C | 4  | optional mezzanine card 4 - Fabric B |
| 5  | SD card location                     | 6  | processor CPU2 and heat sink         |
| 7  | hard drive 1                         | 8  | hard drive 0                         |
| 9  | hard-drive backplane                 | 10 | processor CPU1 and heat sink         |
| 11 | video riser card                     |    |                                      |

**Figure 3-11. Inside a Full-Height Blade (PowerEdge M710)**



- |   |                                      |    |   |
|---|--------------------------------------|----|---|
| 1 | optional mezzanine card 1 - Fabric C | 2  | optional mezzanine card 2 - Fabric B          |
| 3 | optional mezzanine card 3 - Fabric C | 4  | optional mezzanine card 4 - Fabric B          |
| 5 | memory modules                       | 6  | processor CPU2 and heat sink                  |
| 7 | hard drives (4)                      | 8  | hard-drive backplane                          |
| 9 | processor CPU1 and heat sink         | 10 | iDRAC6 Enterprise card (under mezzanine card) |

**Figure 3-12. Inside a Full-Height Blade (PowerEdge M610x)**



- |    |  |    |   |
|----|--|----|---|
| 1  | internal SD vFlash card slot                         | 2  | iDRAC6 Enterprise card                  |
| 3  | mezzanine interface card                             | 4  | cable management clip                   |
| 5  | midplane interface card                              | 6  | optional mezzanine card<br>Mezz1_Fab_C1 |
| 7  | optional mezzanine card -<br>Mezz2_Fab_B1            | 8  | PCIe riser                              |
| 9  | standard PCIe cards or PCIe<br>expansion-card blanks | 10 | hard-drive backplane                    |
| 11 | processor CPU2 and heat sink                         | 12 | memory modules (B1 to B6)               |
| 13 | memory modules (A1 to A6)                            | 14 | processor CPU1 and heat sink            |

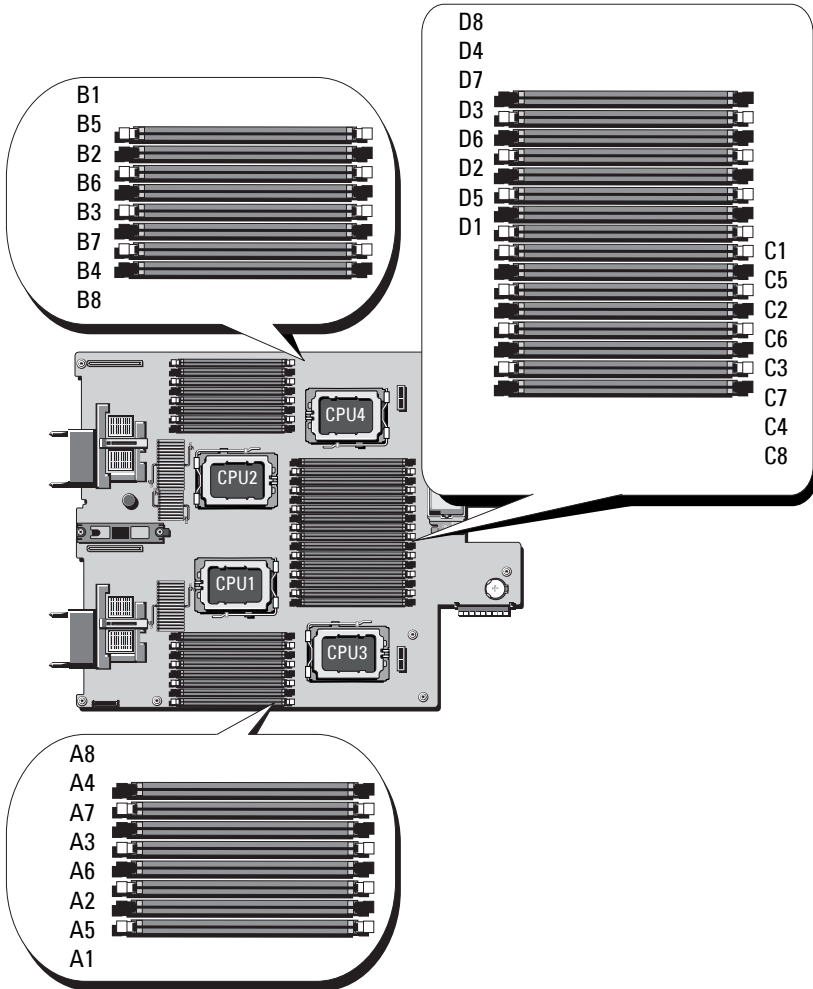
# System Memory

## System Memory – PowerEdge M915

The system board has 32 memory sockets organized in four channels per processor with two LV DIMMs per channel. This configuration permits the following maximum memory configurations:

1 GB, 2 GB, 4 GB, 8 GB, and 16 GB LV DIMMs are supported per channel, for a total of up to 512 GB. Single-rank, dual rank, and quad-rank RDIMMs are supported.


**Figure 3-13. Memory Locations – PowerEdge M915**





## General Memory Module Installation Guidelines – PowerEdge M915

To ensure optimal performance of your system, observe the following guidelines when configuring your system memory:

 **CAUTION: Memory module blanks must be installed in unoccupied memory sockets to maintain proper cooling airflow.**

- Memory modules must be installed in pairs, beginning with the first two sockets in each set of memory modules. These sockets are marked by white retention levers.
- The memory configuration for each processor must be identical.
- Memory modules must be identical in size, speed, and technology in lock-step pair (same colored levers).
- If quad-rank memory modules are mixed with single- or dual-rank modules, the quad-rank modules must be installed in the sockets with the white release levers.
- If pairs of memory modules of different sizes are installed, the larger capacity memory modules must be installed in the lower numbered slots.
- Memory sparing is supported in a four-processor system only if 32 memory modules are installed.
- Memory sparing is supported in a two-processor system only if 16 memory modules are installed.

**Table 3-1. Examples of PowerEdge M915 Memory Configurations**



**NOTE:** DIMMs A1-A8 are assigned to processor 1, DIMMs B1-B8 are assigned to processor 2, and so on.

Total Physical Memory	Number of Processors	Memory Modules – Number and Type	Memory Sparing Support	Memory Module Locations
8 GB	Two	Eight 1 GB	N	A1, A2, A3, A4, B1, B2, B3, B4
16 GB	Two	Eight 2 GB	N	A1, A2, A3, A4, B1, B2, B3, B4
16 GB	Four	Sixteen 1 GB	N	A1, A2, A3, A4, B1, B2, B3, B4, C1, C2, C3, C4, D1, D2, D3, D4

<b>Total Physical Memory</b>	<b>Number of Processors</b>	<b>Memory Modules – Number and Type</b>	<b>Memory Sparing Support</b>	<b>Memory Module Locations</b>
32 GB	Two	Sixteen 2 GB	Y	A1, A2, A3, A4, A5, A6, A7, A8, B1, B2, B3, B4, B5, B6, B7, B8
32 GB	Four	Sixteen 2 GB	N	A1, A2, A3, A4, B1, B2, B3, B4, C1, C2, C3, C4, D1, D2, D3, D4
64 GB	Two	Sixteen 4 GB	Y	A1, A2, A3, A4, A5, A6, A7, A8, B1, B2, B3, B4, B5, B6, B7, B8
64 GB	Four	Sixteen 4 GB	N	A1, A2, A3, A4, B1, B2, B3, B4, C1, C2, C3, C4, D1, D2, D3, D4
96 GB	Two	Eight 4 GB and Eight 8 GB	N	A1, A2, A3, A4, B1, B2, B3, B4, A5, A6, A7, A8, B5, B6, B7, B8 <b>NOTE: 8 GB memory modules must be installed in the slots numbered x1, x2, x3, and x4 and 4 GB memory modules must be installed in slots x5, x6, x7, and x8.</b>
96 GB	Four	Sixteen 4 GB and Sixteen 2 GB	N	A1, A2, A3, A4, A5, A6, A7, A8, B1, B2, B3, B4, B5, B6, B7, B8, C1, C2, C3, C4, C5, C6, C7, C8, D1, D2, D3, D4, D5, D6, D7, D8 <b>NOTE: 4 GB memory modules must be installed in the slots numbered x1, x2, x3, and x4 and 2 GB memory modules must be installed in slots x5, x6, x7, and x8.</b>
128 GB	Two	Sixteen 8 GB	Y	A1, A2, A3, A4, A5, A6, A7, A8, B1, B2, B3, B4, B5, B6, B7, B8

<b>Total Physical Memory</b>	<b>Number of Processors</b>	<b>Memory Modules – Number and Type</b>	<b>Memory Sparring Support</b>	<b>Memory Module Locations</b>
128 GB	Four	Thirty two 4 GB	Y	A1, A2, A3, A4, A5, A6, A7, A8, B1, B2, B3, B4, B5, B6, B7, B8, C1, C2, C3, C4, C5, C6, C7, C8, D1, D2, D3, D4, D5, D6, D7, D8
192 GB <sup>a</sup>	Two	Eight 16 GB and Eight 8 GB	N	A1, A2, A3, A4, B1, B2, B3, B4, A5, A6, A7, A8, B5, B6, B7, B8 <b>NOTE:</b> 8 GB memory modules must be installed in the slots numbered <i>x1, x2, x3,</i> and <i>x4</i> and 4 GB memory modules must be installed in slots <i>x5, x6, x7,</i> and <i>x8.</i>
192 GB	Four	Sixteen 8 GB and Sixteen 4 GB	N	A1, A2, A3, A4, A5, A6, A7, A8, B1, B2, B3, B4, B5, B6, B7, B8, C1, C2, C3, C4, C5, C6, C7, C8, D1, D2, D3, D4, D5, D6, D7, D8 <b>NOTE:</b> 8 GB memory modules must be installed in the slots numbered <i>x1, x2, x3,</i> and <i>x4</i> and 4 GB memory modules must be installed in slots <i>x5, x6, x7,</i> and <i>x8.</i>
256 GB <sup>a</sup>	Two	Sixteen 16 GB	Y	A1, A2, A3, A4, A5, A6, A7, A8, B1, B2, B3, B4, B5, B6, B7, B8
256 GB	Four	Thirty two 8 GB	Y	A1, A2, A3, A4, A5, A6, A7, A8, B1, B2, B3, B4, B5, B6, B7, B8, C1, C2, C3, C4, C5, C6, C7, C8, D1, D2, D3, D4, D5, D6, D7, D8

<b>Total Physical Memory</b>	<b>Number of Processors</b>	<b>Memory Modules – Number and Type</b>	<b>Memory Sparring Support</b>	<b>Memory Module Locations</b>
512 GB	Four	Thirty two 16 GB <sup>a</sup>	Y	A1, A2, A3, A4, A5, A6, A7, A8, B1, B2, B3, B4, B5, B6, B7, B8, C1, C2, C3, C4, C5, C6, C7, C8, D1, D2, D3, D4, D5, D6, D7, D8
1 TB <sup>a</sup>	Four	Thirty two 32 GB <sup>b</sup>	Y	A1, A2, A3, A4, A5, A6, A7, A8, B1, B2, B3, B4, B5, B6, B7, B8, C1, C2, C3, C4, C5, C6, C7, C8, D1, D2, D3, D4, D5, D6, D7, D8

<sup>a</sup> indicates DIMM configurations that operate at 1066 MHz while the rest of the configurations operate at 1333 MHz.

<sup>b</sup> when available

### **Non-Optimal Memory Configurations**

System performance can be affected if your memory configuration does not conform to the preceding installation guidelines. Your system may issue an error message during start-up stating that your memory configuration is non-optimal.

### **Memory Sparring Support – PowerEdge M915**

The memory sparring feature must also be enabled in the **Memory Information** screen of the System Setup program. See "Memory Settings Screen" on page 140. To use memory sparring, you must disable node interleaving.

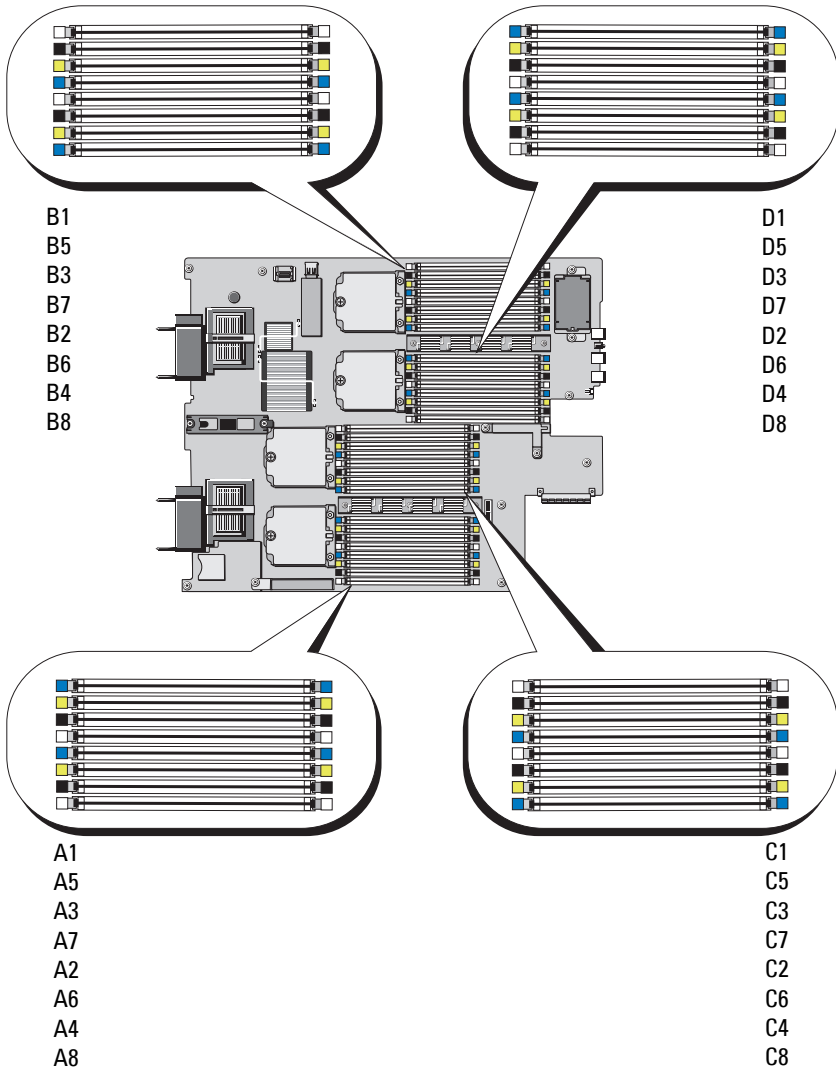
## **System Memory – PowerEdge M910**

Your system supports DDR3 registered DIMMs (RDIMMS) only.

32 memory sockets are located on the system board, organized in eight channels with four DIMMs per channel. This configuration permits the following maximum memory configurations:

Up to four 2 GB, 4 GB, 8 GB, and 16 GB RDIMMs are supported per channel, for a total of up to 512 GB. Single-rank, dual rank, and quad-rank RDIMMs are supported.

**Figure 3-14. Memory Locations - PowerEdge M910**



## General Memory Module Installation Guidelines - PowerEdge M910

To ensure optimal performance of your system, observe the following general guidelines when configuring your system memory:

- Memory modules must be installed in pairs, beginning with the first two sockets in each set of memory modules. These sockets are marked by white retention levers.
- The memory configuration for each processor must be identical.
- Memory modules must be identical in size, speed, and technology in lock-step pair (same colored levers).
- If quad-rank memory modules are mixed with single- or dual-rank modules, the quad-rank modules must be installed in the sockets with the white release levers.
- If pairs of memory modules of different sizes are installed, the larger capacity memory modules must be installed in the lower numbered slots.
- Memory mirroring and memory sparing are supported only if 32 memory modules are installed.

**Table 3-2. Examples of PowerEdge M910 Memory Configurations**

<b>Total Physical Memory</b>	<b>Memory Modules – Number and Type</b>	<b>Memory Module Locations</b>
4 GB	Four 1 GB	A1, A2, B1, B2
8 GB	Eight 1 GB	A1, A2, B1, B2, C1, C2, D1, D2
16 GB	Eight 2 GB	A1, A2, B1, B2, C1, C2, D1, D2
32 GB	Eight 4 GB	A1, A2, B1, B2, C1, C2, D1, D2
64 GB	Sixteen 4 GB	A1, A2, A3, A4, B1, B2, B3, B4, C1, C2, C3, C4, D1, D2, D3, D4
96 GB	Twenty-four 4 GB	A1, A2, A3, A4, A5, A6, B1, B2, B3, B4, B5, B6, C1, C2, C3, C4, C5, C6, D1, D2, D3, D4, D5, D6
128 GB	Thirty-two 4 GB	A1, A2, A3, A4, A5, A6, A7, A8, B1, B2, B3, B4, B5, B6, B7, B8, C1, C2, C3, C4, C5, C6, C7, C8, D1, D2, D3, D4, D5, D6, D7, D8
128 GB	Sixteen 8 GB	A1, A2, A3, A4, B1, B2, B3, B4, C1, C2, C3, C4, D1, D2, D3, D4

**Table 3-2. Examples of PowerEdge M910 Memory Configurations (continued)**

<b>Total Physical Memory</b>	<b>Memory Modules – Number and Type</b>	<b>Memory Module Locations</b>
128 GB	Eight 16 GB	A1, A2, B1, B2, C1, C2, D1, D2
160 GB	Twenty-four 4 GB and Eight 8 GB	A1, A2, A3, A4, A5, A6, A7, A8, B1, B2, B3, B4, B5, B6, B7, B8, C1, C2, C3, C4, C5, C6, C7, C8, D1, D2, D3, D4, D5, D6, D7, D8  <b>NOTE:</b> 8 GB memory modules must be installed in the lower numbered slots x1, x2 and 4 GB memory modules must be installed in slots x3, x4, x5, x6, x7, x8.
192 GB	Twenty-four 8 GB	A1, A2, A3, A4, A5, A6, B1, B2, B3, B4, B5, B6, C1, C2, C3, C4, C5, C6, D1, D2, D3, D4, D5, D6
192 GB	Sixteen 4 GB and Sixteen 8 GB	A1, A2, A3, A4, A5, A6, A7, A8, B1, B2, B3, B4, B5, B6, B7, B8, C1, C2, C3, C4, C5, C6, C7, C8, D1, D2, D3, D4, D5, D6, D7, D8  <b>NOTE:</b> 8 GB memory modules must be installed in the lower numbered slots x1, x2, x3, x4 and 4 GB memory modules must be installed in slots x5, x6, x7, x8.
256 GB	Thirty-two 8 GB	A1, A2, A3, A4, A5, A6, A7, A8, B1, B2, B3, B4, B5, B6, B7, B8, C1, C2, C3, C4, C5, C6, C7, C8, D1, D2, D3, D4, D5, D6, D7, D8
256 GB	Sixteen 16 GB	A1, A2, A3, A4, B1, B2, B3, B4, C1, C2, C3, C4, D1, D2, D3, D4
384 GB	Sixteen 8 GB and Sixteen 16 GB	A1, A2, A3, A4, A5, A6, A7, A8, B1, B2, B3, B4, B5, B6, B7, B8, C1, C2, C3, C4, C5, C6, C7, C8, D1, D2, D3, D4, D5, D6, D7, D8  <b>NOTE:</b> 16 GB memory modules must be installed in the lower numbered slots x1, x2, x3, x4 and 8 GB memory modules must be installed in slots x5, x6, x7, x8.
512 GB	Thirty-two 16 GB	A1, A2, A3, A4, A5, A6, A7, A8, B1, B2, B3, B4, B5, B6, B7, B8, C1, C2, C3, C4, C5, C6, C7, C8, D1, D2, D3, D4, D5, D6, D7, D8



## Non-Optimal Memory Configurations

System performance can be affected if your memory configuration does not conform to the preceding installation guidelines. Your system may issue an error message during start-up stating that your memory configuration is non-optimal.

## Memory Sparing Support – PowerEdge M910

Memory sparing (spare bank) is supported in systems that have one of the memory configurations shown in Table 3-3. The memory sparing feature must also be enabled in the **Memory Information** screen of the System Setup program. See "Memory Settings Screen" on page 140. To use memory sparing, you must disable node interleaving.

**Table 3-3. Memory Sparing Configurations - PowerEdge M910**

<b>Total System Memory</b>	<b>Usable System Memory</b>	<b>Memory Modules - Number and Size</b>	<b>Memory Module Locations</b>
128 GB	112 GB	Thirty-two 4 GB	A1, A2, A3, A4, A5, A6, A7, A8, B1, B2, B3, B4, B5, B6, B7, B8, C1, C2, C3, C4, C5, C6, C7, C8, D1, D2, D3, D4, D5, D6, D7, D8
256 GB	224 GB	Thirty-two 8 GB	
512 GB	448 GB	Thirty-two 16 GB	

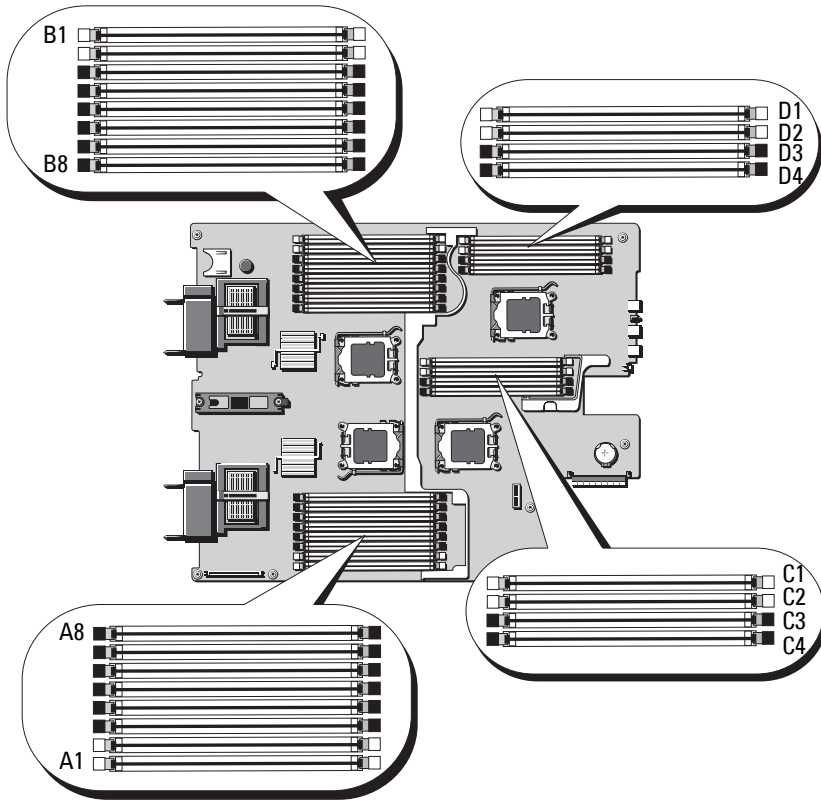
## System Memory – PowerEdge M905

You can upgrade your system memory to a maximum of 192 GB by installing up to twenty-four 667 MHz registered DDR2 memory modules in sets of 1 GB, 2 GB, 4 GB, or 8 GB memory modules. (Dual-rank 8 GB modules are supported; quad-rank 8 GB modules are not supported.) Each processor has four memory channels, organized in sets of two channels.



**NOTE:** If more than four memory modules are installed per processor, the memory modules are downclocked to operate at 533 MHz.

**Figure 3-15. Memory Locations – PowerEdge M905**



**General Memory Module Installation Guidelines – PowerEdge M905**

To ensure optimal performance of your system, observe the following guidelines when configuring your system memory:

- Memory modules must be installed in pairs, beginning with the first two sockets in each set of memory modules. These sockets are marked by white retention levers.
- All memory modules in the blade must be identical in speed and technology. The memory modules in each pair must be the same size.

- If pairs of memory modules of different sizes are installed, the larger capacity memory modules must be installed in the lower numbered slots.
- Memory sparing is supported if 24 memory modules are installed. (Memory mirroring is not supported.)

Table 3-4 shows examples of supported memory configurations.



**CAUTION: Memory module blanks must be installed in unoccupied memory sockets to maintain proper cooling airflow.**

**Table 3-4. Examples of PowerEdge M905 Memory Configurations**

<b>Total System Memory</b>	<b>Memory Modules - Number and Size</b>	<b>Memory Module Locations</b>
8 GB	Eight 1 GB	A1, A2, B1, B2, C1, C2, D1, D2
16 GB	Sixteen 1 GB	A1, A2, A3, A4, B1, B2, B3, B4, C1, C2, C3, C4, D1, D2, D3, D4
16 GB	Eight 2 GB	A1, A2, B1, B2, C1, C2, D1, D2
32 GB	Eight 4 GB	A1, A2, B1, B2, C1, C2, D1, D2
32 GB	Sixteen 2 GB	A1, A2, A3, A4, B1, B2, B3, B4, C1, C2, C3, C4, D1, D2, D3, D4
48 GB	Twenty-four 2 GB	A1, A2, A3, A4, A5, A6, A7, A8, B1, B2, B3, B4, B5, B6, B7, B8, C1, C2, C3, C4, D1, D2, D3, D4
64 GB*	Eight 8 GB	A1, A2, B1, B2, C1, C2, D1, D2
64 GB*	Sixteen 4 GB	A1, A2, A3, A4, B1, B2, B3, B4, C1, C2, C3, C4, D1, D2, D3, D4
96 GB	Twenty-four 4 GB	A1, A2, A3, A4, A5, A6, A7, A8, B1, B2, B3, B4, B5, B6, B7, B8, C1, C2, C3, C4, D1, D2, D3, D4
128 GB	Sixteen 8 GB	A1, A2, A3, A4, B1, B2, B3, B4, C1, C2, C3, C4, D1, D2, D3, D4
192 GB	Twenty-four 8 GB	A1, A2, A3, A4, A5, A6, A7, A8, B1, B2, B3, B4, B5, B6, B7, B8, C1, C2, C3, C4, D1, D2, D3, D4

\*If 64 GB of memory is installed, the system recognizes only 63.75 GB during POST.

## Non-Optimal Memory Configurations

System performance can be affected if your memory configuration does not conform to the preceding installation guidelines. Your system may issue an error message during start-up stating that your memory configuration is non-optimal.

## Memory Sparing Support – PowerEdge M905

Memory sparing (spare bank) is supported in systems that have one of the memory configurations shown in Table 3-5. The memory sparing feature must also be enabled in the **Memory Information** screen of the System Setup program. See "Memory Settings Screen" on page 140. To use memory sparing, you must disable node interleaving.

**Table 3-5. Memory Sparing Configurations – PowerEdge M905**



**NOTE:** Memory sparing is supported if 24 identical memory modules are installed.

<b>Total System Memory</b>	<b>Usable System Memory</b>	<b>Memory Modules - Number and Size</b>	<b>Memory Module Locations</b>
48 GB	40 GB	Twenty-four 2 GB	A1, A2, A3, A4, A5, A6, A7, A8, B1, B2, B3, B4, B5, B6, B7, B8, C1, C2, C3, C4, D1, D2, D3, D4
96 GB	80 GB	Twenty-four 4 GB	
192 GB	160 GB	Twenty-four 8 GB	

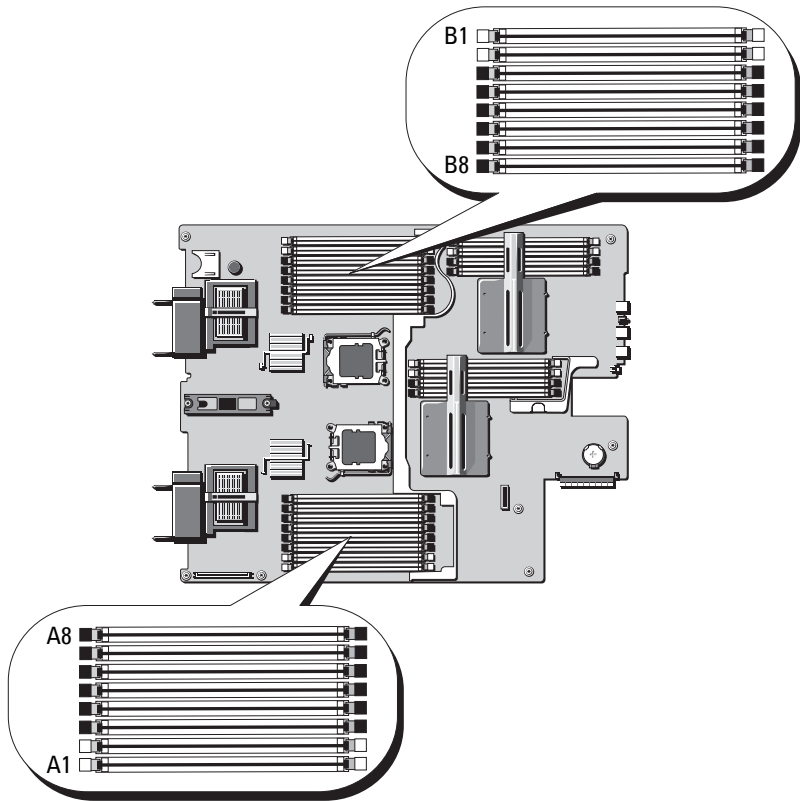
## System Memory – PowerEdge M805

You can upgrade your system memory to a maximum of 128 GB by installing 667 MHz registered DDR2 memory modules in sets of 1 GB, 2 GB, 4 GB, or 8 GB memory modules. (Dual-rank 8 GB modules are supported; quad-rank 8 GB modules are not supported.) Each processor has four memory channels, organized in sets of two channels.



**NOTE:** If more than four memory modules are installed per processor, the memory modules are downclocked to operate at 533 MHz.

**Figure 3-16. Memory Locations – PowerEdge M805**



**General Memory Module Installation Guidelines – PowerEdge M805**

To ensure optimal performance of your system, observe the following guidelines when installing your system memory:

- Memory modules must be installed in pairs of identically-sized DIMMs, beginning with slots A1 and A2 (processor 1) and B1 and B2. These slots are marked by white ejector tabs.
- All memory modules in the blade must be identical in speed and technology. The memory modules in each pair must be the same size.

- Memory must be installed in the same configuration (symmetrically) for both processors.
- If pairs of memory modules of different sizes are installed, the larger capacity memory modules must be installed in the lower numbered slots.
- Memory sparing is supported if 16 memory modules are installed. (Memory mirroring is not supported.)

Table 3-6 shows examples of supported memory configurations.



**CAUTION: Memory module blanks must be installed in unoccupied memory sockets to maintain proper cooling airflow.**

**Table 3-6. Examples of PowerEdge M805 Memory Configurations**

<b>Total System Memory</b>	<b>Memory Modules - Number and Size</b>	<b>Memory Module Locations</b>
4 GB	Four 1 GB	A1, A2, B1, B2
8 GB	Eight 1 GB	A1, A2, A3, A4, B1, B2, B3, B4
8 GB	Four 2 GB	A1, A2, B1, B2
12 GB	Twelve 2 GB	A1, A2, A3, A4, A5, A6, B1, B2, B3, B4, B5, B6
16 GB	Sixteen 1 GB	A1, A2, A3, A4, A5, A6, A7, A8, B1, B2, B3, B4, B5, B6, B7, B8
16 GB	Eight 2 GB	A1, A2, A3, A4, B1, B2, B3, B4
16 GB	Four 4 GB	A1, A2, B1, B2
24 GB	Twelve 2 GB	A1, A2, A3, A4, A5, A6, B1, B2, B3, B4, B5, B6
32 GB	Sixteen 2 GB	A1, A2, A3, A4, A5, A6, A7, A8, B1, B2, B3, B4, B5, B6, B7, B8
32 GB	Eight 4 GB	A1, A2, A3, A4, B1, B2, B3, B4
48 GB	Twelve 4 GB	A1, A2, A3, A4, A5, A6, B1, B2, B3, B4, B5, B6
64 GB*	Sixteen 4 GB	A1, A2, A3, A4, A5, A6, A7, A8, B1, B2, B3, B4, B5, B6, B7, B8

**Table 3-6. Examples of PowerEdge M805 Memory Configurations (continued)**

<b>Total System Memory</b>	<b>Memory Modules - Number and Size</b>	<b>Memory Module Locations</b>
64 GB*	Eight 8 GB	A1, A2, A3, A4, B1, B2, B3, B4
128 GB	Sixteen 8 GB	A1, A2, A3, A4, A5, A6, A7, A8, B1, B2, B3, B4, B5, B6, B7, B8

\*If 64 GB of memory is installed, the system recognizes only 63.75 GB during POST.

### Non-Optimal Memory Configurations

System performance can be affected if your memory configuration does not conform to the preceding installation guidelines. Your system may issue an error message during start-up stating that your memory configuration is non-optimal.

### Memory Sparring Support - PowerEdge M805

Memory sparing (spare bank) is supported in systems that have one of the memory configurations shown in Table 3-7. The memory sparing feature must also be enabled in the **Memory Information** screen of the System Setup program. See "Memory Settings Screen" on page 140. To use memory sparing, you must disable node interleaving.

**Table 3-7. Memory Sparring Configurations – PowerEdge M805**

**NOTE:** Memory sparing is supported if 16 identical memory modules are installed.

<b>Total System Memory</b>	<b>Usable System Memory</b>	<b>Memory Modules - Number and Size</b>	<b>Memory Module Locations</b>
32 GB	28 GB	Sixteen 2 GB	A1, A2, A3, A4, A5, A6, A7, A8, B1, B2, B3, B4, B5, B6, B7, B8
64 GB	56 GB	Sixteen 4 GB	A1, A2, A3, A4, A5, A6, A7, A8, B1, B2, B3, B4, B5, B6, B7, B8
128 GB	112 GB	Sixteen 8 GB	A1, A2, A3, A4, A5, A6, A7, A8, B1, B2, B3, B4, B5, B6, B7, B8

## **System Memory – PowerEdge M710**

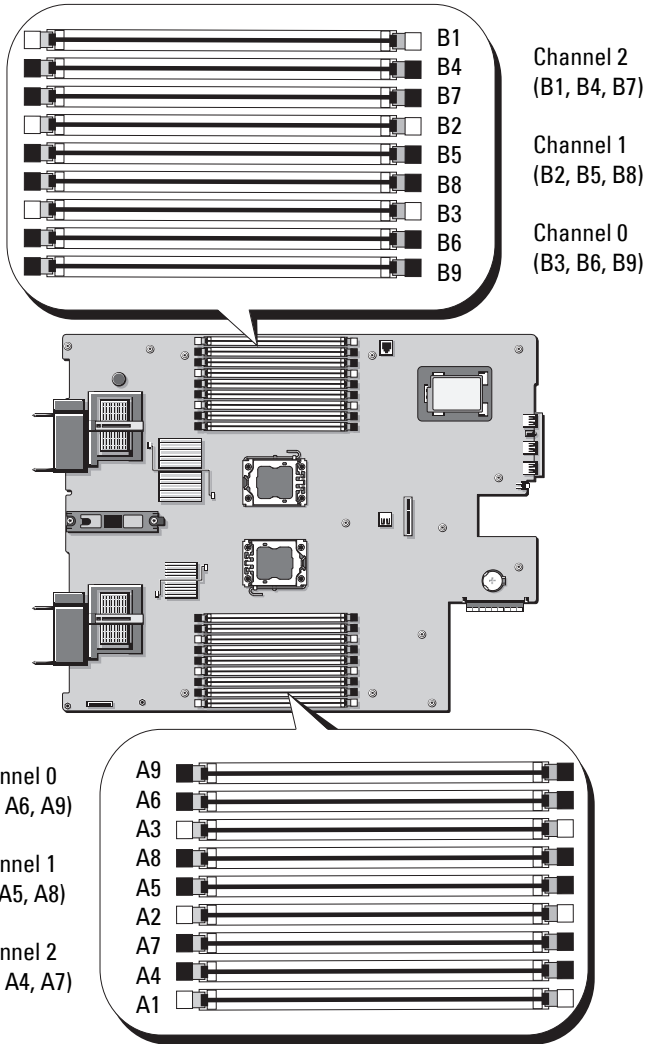
Your system supports DDR3 registered DIMMs (RDIMMS) or unbuffered DIMMs (UDIMMs).

Eighteen memory sockets are located on the system board, organized in three channels with three DIMMs per channel. This configuration permits the following maximum memory configurations:

- Up to three 1 GB, 2 GB, 4 GB, 8 GB and 16 GB RDIMMs are supported per channel, for a total of up to 288 GB. Single-rank, dual rank, and quad-rank RDIMMs are supported.
- One or two 1 GB and 2 GB UDIMMs per channel are supported, for a total of up to 24 GB.



**Figure 3-17. Memory Locations – PowerEdge M710**



## **General Memory Module Installation Guidelines – PowerEdge M710**

To ensure optimal performance of your system, observe the following general guidelines when configuring your system memory:

- RDIMMs and UDIMMs cannot be mixed.
- Memory modules are populated beginning with the socket farthest from the processor (this socket is indicated by a white socket-release lever).
- In a dual-processor configuration, the memory configuration for each processor must be identical.
- If quad-rank memory modules are installed, a maximum of two DIMMs per channel is supported.
- If memory modules with different speeds are installed, they operate at the speed of the slowest installed memory modules.

Three memory channels are allocated to each processor. The number of channels used and the allowable configurations depend on the memory mode selected. The channels are organized as follows:

- Channel 0 - sockets 3, 6, 9
- Channel 1 - sockets 2, 5, 8
- Channel 2 - sockets 1, 4, 7

Sockets A1 through A9 are assigned to CPU1; sockets B1 through B9 are assigned to CPU2.

## **Advanced ECC Mode Support – PowerEdge M710**

In this configuration, channels 0 and 1 are combined to form one 128-bit channel. If a memory error occurs on a given chip, the faulty chip is disabled. Memory modules must be identical in size, speed, and technology in corresponding slots.

## **Memory Mirroring Support – PowerEdge M710**

The system supports memory mirroring if identical memory modules are installed in channel 0 and channel 1 (memory is not installed in channel 2). Mirroring must also be enabled in the System Setup program. In a mirrored configuration, the total available system memory is one-half of the total installed physical memory.

### Independent Channel Mode (Optimizer Mode) – PowerEdge M710

In this mode, all three channels are populated with identical memory modules. This mode permits a larger total memory capacity, but does not support the reliability features of the other modes. To enable this mode, select the **Optimizer** option on the **Memory Settings** screen of the System Setup program. See "Memory Settings Screen" on page 140.

A minimal single-channel configuration of one 1 GB memory module per processor is also supported in this mode.

**Table 3-8. Examples of PowerEdge M710 Memory Configurations**

<b>Total Physical Memory</b>	<b>Memory Modules – Number and Type</b>	<b>Memory Module Locations</b>	<b>Processors</b>	<b>Memory Mode</b>	<b>Available Memory</b>
1 GB	One 1 GB UDIMM	A1	One	Independent channel	1 GB
2 GB	Two 1 GB UDIMMs	A2, A3	One	Mirroring	1 GB
2 GB	Two 1 GB UDIMMs	A2, A3	One	Advanced ECC	2 GB
2 GB	Two 1 GB UDIMMs	A1, B1	Two	Independent channel	2 GB
4 GB	Two 2 GB UDIMMs	A2, A3	One	Mirroring	2 GB
4 GB	Two 2 GB UDIMMs	A2, A3	One	Advanced ECC	4 GB
4 GB	Four 1 GB UDIMMs	A2, A3, B2, B3	Two	Mirroring	2 GB
4 GB	Four 1 GB UDIMMs	A2, A3, B2, B3	Two	Advanced ECC	4 GB
6 GB	Six 1 GB UDIMMs	A1, A2, A3, B1, B2, B3	Two	Independent channel	6 GB
6 GB	Three 2 GB UDIMMs	A1, A2, A3	One	Independent channel	6 GB
8 GB	Four 2 GB UDIMMs	A2, A3, B2, B3	Two	Mirroring	4 GB

**Table 3-8. Examples of PowerEdge M710 Memory Configurations (continued)**

<b>Total Physical Memory</b>	<b>Memory Modules – Number and Type</b>	<b>Memory Module Locations</b>	<b>Processors</b>	<b>Memory Mode</b>	<b>Available Memory</b>
8 GB	Four 2 GB UDIMMs	A2, A3, B2, B3	Two	Advanced ECC	8 GB
8 GB	Four 2 GB UDIMMs	A2, A3, A5, A6	One	Mirroring	4 Gb
8 GB	Four 2 GB UDIMMs	A2, A3, A5, A6	One	Advanced ECC	8 Gb
12 GB	Six 2 GB UDIMMs	A1, A2, A3, A4, A5, A6	One	Independent channel	12 GB
12 GB	Six 2 GB UDIMMs	A1, A2, A3, B1, B2, B3	Two	Independent channel	12 GB
16 GB	Eight 2 GB UDIMMs	A2, A3, A5, A6, B2, B3, B5, B6	Two	Mirroring	8 GB
16 GB	Eight 2 GB UDIMMs	A2, A3, A5, A6, B2, B3, B5, B6	Two	Advanced ECC	16 GB
24 GB	Twelve 2 GB RDIMMs	A2, A3, A5, A6, A8, A9, B2, B3, B5, B6, B8, B9	One	Advanced ECC	24 GB
24 GB	Six 4 GB UDIMMs	A1, A2, A3, A4, A5, A6	One	Independent channel	24 GB
24 GB	Six 4 GB RDIMMs	A1, A2, A3, B1, B2, B3	Two	Independent channel	24 GB
32 GB	Eight 4 GB RDIMMs	A2, A3, A5, A6, B2, B3, B5, B6	Two	Mirroring	16 GB
32 GB	Eight 4 GB RDIMMs	A2, A3, A5, A6, B2, B3, B5, B6	Two	Advanced ECC	32 GB
36 GB	Nine 4 GB RDIMMs	A1, A2, A3, A4, A5, A6, A7, A8, A9	One	Independent channel	36 GB
64 GB	Eight 8 GB RDIMMs	A2, A3, A5, A6, B2, B3, B5, B6	Two	Mirroring	32 GB

**Table 3-8. Examples of PowerEdge M710 Memory Configurations (continued)**

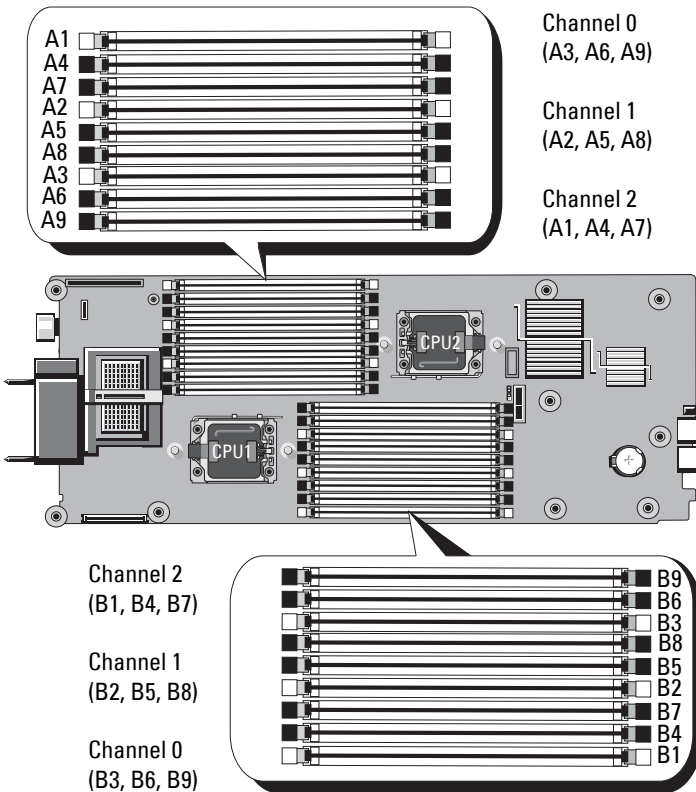
<b>Total Physical Memory</b>	<b>Memory Modules – Number and Type</b>	<b>Memory Module Locations</b>	<b>Processors</b>	<b>Memory Mode</b>	<b>Available Memory</b>
64 GB	Eight 8 GB RDIMMs	A2, A3, A5, A6, B2, B3, B5, B6	Two	Advanced ECC	64 GB
72 GB	Eighteen 4 GB RDIMMs	A1, A2, A3, A4, A5, A6, A7, A8, A9, B1, B2, B3, B4, B5, B6, B7, B8, B9	Two	Independent channel	72 GB
96 GB	Twelve 8 GB RDIMMs	A1, A2, A3, A4, A5, A6, B1, B2, B3, B4, B5, B6	Two	Independent channel	96 GB
144 GB	Eighteen 8 GB RDIMMs	A1, A2, A3, A4, A5, A6, A7, A8, A9, B1, B2, B3, B4, B5, B6, B7, B8, B9	Two	Independent channel	144 GB
192 GB	Twelve 16 GB RDIMMs	A1, A2, A3, A4, A5, A6, B1, B2, B3, B4, B5, B6	Two	Independent channel	192 GB
288 GB	Eighteen 16 GB RDIMMs	A1, A2, A3, A4, A5, A6, A7, A8, A9, B1, B2, B3, B4, B5, B6, B7, B8, B9	Two	Independent channel	288 GB

## System Memory – PowerEdge M710HD

Your system supports DDR3 registered DIMMs (RDIMMs).

Eighteen memory sockets are located on the system board, organized in three channels per processor with three DIMMs per channel. This configuration supports up to three 2 GB, 4 GB, 8 GB and up to two 16 GB RDIMMs per channel, for a total of up to 192 GB. Single-rank, dual-rank, and quad-rank RDIMMs are supported.

**Figure 3-18. Memory Locations – PowerEdge M710HD**



## **General Memory Module Installation Guidelines – PowerEdge M710HD**

To ensure optimal performance of your system, observe the following general guidelines when configuring your system memory:

- Memory modules are populated beginning with the socket farthest from the processor (this socket is indicated by a white socket-release lever).
- In a dual-processor configuration, the memory configuration for each processor must be identical.
- If quad-rank memory modules are installed, a maximum of two DIMMs per channel is supported.
- If memory modules with different speeds are installed, they operate at the speed of the slowest installed memory modules.

Three DDR3 memory channels are allocated to each processor. The number of channels used and the allowable configurations depend on the memory mode selected. The channels are organized as follows:

- Channel 0 - sockets 3, 6, 9
- Channel 1 - sockets 2, 5, 8
- Channel 2 - sockets 1, 4, 7

Sockets A1 through A9 are assigned to CPU1; sockets B1 through B9 are assigned to CPU2.

## **Advanced ECC Mode Support – PowerEdge M710HD**

In this configuration, channels 0 and 1 are combined to form one 128-bit channel. If a memory error occurs on a given chip, the faulty chip is disabled. Memory modules must be identical in size, speed, and technology in corresponding slots.

## **Memory Mirroring Support – PowerEdge M710HD**

The system supports memory mirroring if identical memory modules are installed in channel 0 and channel 1 (memory is not installed in channel 2). Mirroring must also be enabled in the System Setup program. In a mirrored configuration, the total available system memory is one-half of the total installed physical memory.

## Memory Sparing Support – PowerEdge M710HD



**NOTE:** For memory sparing support, your system must be installed with Intel Xeon 5600 series processors.

Memory sparing (spare bank) is supported in systems that have one of the memory configurations shown in Table 3-9. The memory sparing feature must also be enabled in the **Memory Information** screen of the System Setup program. See "Memory Settings Screen" on page 140. To use memory sparing, you must disable node interleaving.

## Independent Channel Mode (Optimizer Mode) – PowerEdge M710HD

In this mode, all three channels are populated with identical memory modules. This mode permits a larger total memory capacity, but does not support the reliability features of the other modes. To enable this mode, select the **Optimizer** option on the **Memory Settings** screen of the System Setup program. See "Memory Settings Screen" on page 140.

A minimal single-channel configuration of one 1 GB memory module per processor is also supported in this mode.

**Table 3-9. Examples of PowerEdge M710HD Memory Configurations**

<b>Total Physical Memory</b>	<b>Memory Modules – Number and Type</b>	<b>Memory Module Locations</b>	<b>Processors</b>	<b>Memory Mode</b>	<b>Available Memory</b>
1 GB	One 1 GB UDIMM	A1	One	Independent channel	1 GB
2 GB	Two 1 GB UDIMMs	A2, A3	One	Mirroring	1 GB
2 GB	Two 1 GB UDIMMs	A2, A3	One	Advanced ECC	2 GB
2 GB	Two 1 GB UDIMMs	A1, B1	Two	Independent channel	2 GB
4 GB	Two 2 GB UDIMMs	A2, A3	One	Mirroring	2 GB
4 GB	Two 2 GB UDIMMs	A2, A3	One	Advanced ECC	4 GB



**Table 3-9. Examples of PowerEdge M710HD Memory Configurations (continued)**

<b>Total Physical Memory</b>	<b>Memory Modules – Number and Type</b>	<b>Memory Module Locations</b>	<b>Processors</b>	<b>Memory Mode</b>	<b>Available Memory</b>
4 GB	Four 1 GB UDIMMs	A2, A3, B2, B3	Two	Mirroring	2 GB
4 GB	Four 1 GB UDIMMs	A2, A3, B2, B3	Two	Advanced ECC	4 GB
6 GB	Six 1 GB UDIMMs	A1, A2, A3, B1, B2, B3	Two	Independent channel	6 GB
6 GB	Three 2 GB UDIMMs	A1, A2, A3	One	Independent channel	6 GB
8 GB	Four 2 GB UDIMMs	A2, A3, B2, B3	Two	Mirroring	4 GB
8 GB	Four 2 GB UDIMMs	A2, A3, B2, B3	Two	Advanced ECC	8 GB
8 GB	Four 2 GB UDIMMs	A2, A3, A5, A6	One	Mirroring	4 Gb
8 GB	Four 2 GB UDIMMs	A2, A3, A5, A6	One	Advanced ECC	8 Gb
12 GB	Six 2 GB UDIMMs	A1, A2, A3, A4, A5, A6	One	Independent channel	12 GB
12 GB	Six 2 GB UDIMMs	A1, A2, A3, B1, B2, B3	Two	Independent channel	12 GB
16 GB	Eight 2 GB UDIMMs	A2, A3, A5, A6, B2, B3, B5, B6	Two	Mirroring	8 GB
16 GB	Eight 2 GB UDIMMs	A2, A3, A5, A6, B2, B3, B5, B6	Two	Advanced ECC	16 GB
24 GB	Six 4 GB UDIMMs	A1, A2, A3, A4, A5, A6	One	Independent channel	24 GB
24 GB	Six 4 GB RDIMMs	A1, A2, A3, B1, B2, B3	Two	Independent channel	24 GB
32 GB	Eight 4 GB RDIMMs	A2, A3, A5, A6, B2, B3, B5, B6	Two	Mirroring	16 GB

**Table 3-9. Examples of PowerEdge M710HD Memory Configurations (continued)**

<b>Total Physical Memory</b>	<b>Memory Modules – Number and Type</b>	<b>Memory Module Locations</b>	<b>Processors</b>	<b>Memory Mode</b>	<b>Available Memory</b>
32 GB	Eight 4 GB RDIMMs	A2, A3, A5, A6, B2, B3, B5, B6	Two	Advanced ECC	32 GB
36 GB	Nine 4 GB RDIMMs	A1, A2, A3, A4, A5, A6, A7, A8, A9	One	Independent channel	36 GB
64 GB	Eight 8 GB RDIMMs	A2, A3, A5, A6, B2, B3, B5, B6	Two	Mirroring	32 GB
64 GB	Eight 8 GB RDIMMs	A2, A3, A5, A6, B2, B3, B5, B6	Two	Advanced ECC	64 GB
72 GB	Eighteen 4 GB RDIMMs	A1, A2, A3, A4, A5, A6, A7, A8, A9, B1, B2, B3, B4, B5, B6, B7, B8, B9	Two	Independent channel	72 GB
96 GB	Twelve 8 GB RDIMMs	A1, A2, A3, A4, A5, A6, B1, B2, B3, B4, B5, B6	Two	Independent channel	96 GB
128 GB	Eight 16 GB RDIMMs	A2, A3, A5, A6, B2, B3, B5, B6	Two	Mirroring	64 GB
128 GB	Eight 16 GB RDIMMs	A2, A3, A5, A6, B2, B3, B5, B6	Two	Advanced ECC	128 GB
144 GB	Eighteen 8 GB RDIMMs	A1, A2, A3, A4, A5, A6, A7, A8, A9, B1, B2, B3, B4, B5, B6, B7, B8, B9	Two	Independent channel	144 GB
192 GB	Twelve 16 GB RDIMMs	A1, A2, A3, A4, A5, A6, B1, B2, B3, B4, B5, B6	Two	Independent channel	192 GB

**Table 3-9. Examples of PowerEdge M710HD Memory Configurations (continued)**

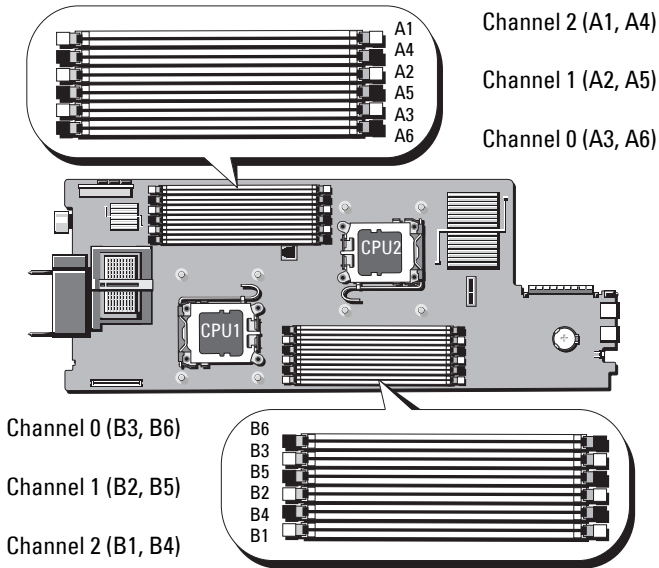
<b>Total Physical Memory</b>	<b>Memory Modules – Number and Type</b>	<b>Memory Module Locations</b>	<b>Processors</b>	<b>Memory Mode</b>	<b>Available Memory</b>
288 GB	Eighteen 16 GB RDIMMs	A1, A2, A3, A4, A5, A6, A7, A8, A9, B1, B2, B3, B4, B5, B6, B7, B8, B9	Two	Independent channel	288 GB

### **System Memory – PowerEdge M610/M610x**

Your system supports DDR3 registered DIMMs (RDIMMS) or unbuffered DIMMs (UDIMMs). Twelve memory sockets are located on the system board, allowing for the following maximum memory configurations:

- 1 GB, 2 GB, 4 GB, 8 GB, and 16 GB RDIMMs (when available) are supported, for a total of up to 192 GB. Single-rank, dual-rank, and quad-rank RDIMMs are supported.
- 1 GB and 2 GB UDIMMs are supported, for a total of up to 24 GB.

**Figure 3-19. Memory Locations – PowerEdge M610/M610x**



**General Memory Module Installation Guidelines – PowerEdge M610/M610x**

To ensure optimal performance of your system, observe the following general guidelines when configuring your system memory:

- RDIMMs and UDIMMs cannot be mixed.
- Memory modules are populated beginning with the socket farthest from the processor (this socket is indicated by a white socket-release lever).
- In a dual-processor configuration, the memory configuration for each processor must be identical
- If quad-rank memory modules are installed, a maximum of two DIMMs per channel is supported.
- If memory modules with different speeds are installed, they operate at the speed of the slowest installed memory modules.

Three memory channels are allocated to each processor. The number of channels used and the allowable configurations depend on the memory mode selected. The channels are organized as follows:

- Channel 0 - sockets 3, 6
- Channel 1 - sockets 2, 5
- Channel 2 - sockets 1, 4

Sockets A1 through A6 are assigned to CPU1; sockets B1 through B6 are assigned to CPU2.

### **Advanced ECC Mode Support – PowerEdge M610/M610x**

In this configuration, channels 0 and 1 are combined to form one 128-bit channel. If a memory error occurs on a given chip, the faulty chip is disabled. Memory modules must be identical in size, speed, and technology in corresponding slots.

### **Memory Mirroring Support – PowerEdge M610/M610x**

The system supports memory mirroring if identical memory modules are installed in channel 0 and channel 1 (memory is not installed in channel 2). Mirroring must also be enabled in the System Setup program. In a mirrored configuration, the total available system memory is one-half of the total installed physical memory.

### Independent Channel Mode (Optimizer Mode) – PowerEdge M610/M610x

In this mode, all three channels are populated with identical memory modules. This mode permits a larger total memory capacity, but does not support the reliability features of the other modes. To enable this mode, select the **Optimizer** option on the **Memory Settings** screen of the System Setup program. See "Memory Settings Screen" on page 140. A minimal single-channel configuration of one 1 GB memory module per processor is also supported in this mode.

**Table 3-10. Examples of PowerEdge M610/M610x Memory Configurations**

<b>Total Physical Memory</b>	<b>Memory Modules – Number and Type</b>	<b>Memory Module Locations</b>	<b>Processors</b>	<b>Memory Mode</b>	<b>Available Memory</b>
1 GB	One 1 GB UDIMM	A1	One	Independent channel	1 GB
2 GB	Two 1 GB UDIMMs	A2, A3	One	Advanced ECC or mirroring	1 GB
2 GB	Two 1 GB UDIMMs	A1, B1	Two	Independent channel	2 GB
4 GB	Two 2 GB UDIMMs	A2, A3	One	Mirroring	2 GB
4 GB	Two 2 GB UDIMMs	A2, A3	One	Advanced ECC	4 GB
4 GB	Four 1 GB UDIMMs	A2, A3, B2, B3	Two	Mirroring	2 GB
4 GB	Four 1 GB UDIMMs	A2, A3, B2, B3	Two	Advanced ECC	4 GB
6 GB	Six 1 GB UDIMMs	A1, A2, A3, B1, B2, B3	Two	Independent channel	6 GB
6 GB	Three 2 GB UDIMMs	A1, A2, A3	One	Independent channel	6 GB
8 GB	Four 2 GB UDIMMs	A2, A3, B2, B3	Two	Mirroring	4 GB

**Table 3-10. Examples of PowerEdge M610/M610x Memory Configurations (continued)**

<b>Total Physical Memory</b>	<b>Memory Modules – Number and Type</b>	<b>Memory Module Locations</b>	<b>Processors</b>	<b>Memory Mode</b>	<b>Available Memory</b>
8 GB	Four 2 GB UDIMMs	A2, A3, B2, B3	Two	Advanced ECC	8 GB
8 GB	Four 2 GB UDIMMs	A2, A3, A5, A6	One	Mirroring	4 Gb
8 GB	Four 2 GB UDIMMs	A2, A3, A5, A6	One	Advanced ECC	8 Gb
12 GB	Six 2 GB UDIMMs	A1, A2, A3, B1, B2, B3	Two	Advanced ECC	12 GB
12 GB	Six 2 GB UDIMMs	A1, A2, A3, A4, A5, A6	One	Advanced ECC	12 GB
16 GB	Eight 2 GB UDIMMs	A2, A3, A5, A6, B2, B3, B5, B6	Two	Mirroring	8 GB
16 GB	Eight 2 GB UDIMMs	A2, A3, A5, A6, B2, B3, B5, B6	Two	Advanced ECC	16 GB
24 GB	Twelve 2 GB UDIMMs	A1, A2, A3, A4, A5, A6, B1, B2, B3, B4, B5, B6	Two	Independent channel	24 GB
24 GB	Six 4 GB RDIMMs	A1, A2, A3, B1, B2, B3	Two	Independent channel	24 GB
32 GB	Eight 4 GB RDIMMs	A2, A3, A5, A6, B2, B3, B5, B6	Two	Mirroring	16 GB
32 GB	Eight 4 GB RDIMMs	A2, A3, A5, A6, B2, B3, B5, B6	Two	Advanced ECC	32 GB
48 GB	Twelve 4 GB RDIMMs	A1, A2, A3, A4, A5, A6, B1, B2, B3, B4, B5, B6	Two	Independent channel	48 GB
64 GB	Eight 8 GB RDIMMs	A2, A3, A5, A6, B2, B3, B5, B6	Two	Mirroring	32 GB
64 GB	Eight 8 GB RDIMMs	A2, A3, A5, A6, B2, B3, B5, B6	Two	Advanced ECC	64 GB

**Table 3-10. Examples of PowerEdge M610/M610x Memory Configurations (continued)**

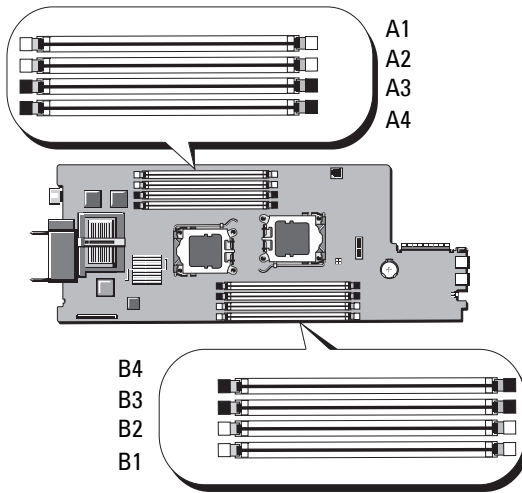
<b>Total Physical Memory</b>	<b>Memory Modules – Number and Type</b>	<b>Memory Module Locations</b>	<b>Processors</b>	<b>Memory Mode</b>	<b>Available Memory</b>
96 GB	Twelve 8 GB RDIMMs	A1, A2, A3, A4, A5, A6, B1, B2, B3, B4, B5, B6	Two	Independent channel	96 GB
128 GB	Eight 16 GB RDIMMs	A2, A3, A5, A6, B2, B3, B5, B6	Two	Mirroring	64 GB
128 GB	Eight 16 GB RDIMMs	A2, A3, A5, A6, B2, B3, B5, B6	Two	Advanced ECC	128 GB
192 GB	Twelve 16 GB RDIMMs	A1, A2, A3, A4, A5, A6, B1, B2, B3, B4, B5, B6	Two	Independent channel	192 GB

**System Memory – PowerEdge M605**

You can upgrade your system memory to a maximum of 16 GB (single processor) or 32 GB (dual processors) by installing 667 or 800 MHz registered DDR2 memory modules in sets of 512 MB, 1 GB, 2 GB, 4 GB, or 8 GB modules. Each processor has four memory channels, organized in sets of two channels.



**Figure 3-20. Memory Locations – PowerEdge M605**



**General Memory Module Installation Guidelines – PowerEdge M605**

To ensure optimal performance of your system, observe the following guidelines when installing your system memory:

- Memory modules must be installed in pairs of identically-sized DIMMs, beginning with slots A1 and A2 (processor 1) and B1 and B2 (processor 2, if installed). These slots are marked by white ejector tabs.
- All memory modules in the blade must be identical in speed and technology. The memory modules in each pair must be the same size.
- In two-processor configurations, memory must be installed in the same configuration (symmetrically) for both processors.
- If pairs of memory modules of different sizes are installed, the larger capacity memory modules must be installed in the lower numbered slots.
- Memory sparing is supported if four (single-processor systems) or eight (dual-processor systems) memory modules are installed.

Table 3-11 and Table 3-12 show examples of supported single- and dual-processor memory configurations.

### Single-Processor Memory Configurations

 **CAUTION:** Memory module blanks must be installed in unoccupied memory sockets to maintain proper cooling airflow.

**Table 3-11. Single-Processor Memory Configurations – PowerEdge M605**

Total System Memory	CPU 1			
	A1	A2	A3	A4
1 GB	512 MB	512 MB	blank	blank
2 GB	512 MB	512 MB	512 MB	512 MB
2 GB	1 GB	1 GB	blank	blank
4 GB	1 GB	1 GB	1 GB	1 GB
4 GB	2 GB	2 GB	blank	blank
6 GB	2 GB	2 GB	1 GB	1 GB
8 GB	2 GB	2 GB	2 GB	2 GB
8 GB	4 GB	4 GB	blank	blank
12 GB	4 GB	4 GB	2 GB	2 GB
16 GB	4 GB	4 GB	4 GB	4 GB
32 GB	8 GB	8 GB	8 GB	8 GB

### Dual-Processor Memory Configurations

 **CAUTION:** Memory module blanks must be installed in unoccupied memory sockets to maintain proper cooling airflow.

**Table 3-12. Dual-Processor Memory Configurations – PowerEdge M605**

Total System Memory	CPU1				CPU2			
	A1	A2	A3	A4	B1	B2	B3	B4
2 GB	512 MB	512 MB	blank	blank	512 MB	512 MB	blank	blank
4 GB	512 MB	512 MB	512 MB	512 MB	512 MB	512 MB	512 MB	512 MB
4 GB	1 GB	1 GB	blank	blank	1 GB	1 GB	blank	blank
6 GB	1 GB	1 GB	512 MB	512 MB	1 GB	1 GB	512 MB	512 MB
8 GB	1 GB	1 GB	1 GB	1 GB	1 GB	1 GB	1 GB	1 GB
8 GB	2 GB	2 GB	blank	blank	2 GB	2 GB	blank	blank
12 GB	2 GB	2 GB	1 GB	1 GB	2 GB	2 GB	1 GB	1 GB
16 GB	2 GB	2 GB	2 GB	2 GB	2 GB	2 GB	2 GB	2 GB
16 GB	4 GB	4 GB	blank	blank	4 GB	4 GB	blank	blank
24 GB	4 GB	4 GB	2 GB	2 GB	4 GB	4 GB	2 GB	2 GB
32 GB	4 GB	4 GB	4 GB	4 GB	4 GB	4 GB	4 GB	4 GB
64 GB*	8 GB	8 GB	8 GB	8 GB	8 GB	8 GB	8 GB	8 GB

\*If 64 GB of memory is installed, the system recognizes only 63.75 GB during POST.

### **Non-Optimal Memory Configurations**

System performance can be affected if your memory configuration does not conform to the preceding installation guidelines. Your system may issue an error message during start-up stating that your memory configuration is non-optimal.

### **Memory Sparing Support – PowerEdge M605**

Memory sparing is supported in single- or dual-processor systems that have one of the fully populated memory configurations shown in Table 3-13. The memory sparing feature must be enabled in the **Memory Information** screen of the System Setup program. See "Memory Settings Screen" on page 140. To use memory sparing, you must disable node interleaving.

Memory sparing allocates only the first rank of memory of a DIMM. For a single-rank DIMM, the entire capacity of the DIMM must be allocated for sparing along with the adjacent single-rank DIMM to spare a memory channel. For dual-rank DIMMs, two DIMMs are also required for sparing, but as only the first rank of each DIMM is allocated, only half of a dual-rank DIMM's capacity is allocated for sparing. The second ranks on both DIMMs are available memory. Table 3-13 shows how memory sparing splits the available and spared memory in each memory module configuration.

**Table 3-13. Memory Sparing Configurations – PowerEdge M605**

Processor 1				Processor 2				Available Memory	Spared Memory
DIMM 1	DIMM 2	DIMM 3	DIMM 4	DIMM 5	DIMM 6	DIMM 7	DIMM 8	1 CPU / 2 CPUs	1 CPU / 2 CPUs
512 MB	512 MB	512 MB*	512 MB*	512 MB	512 MB	512 MB*	512 MB*	1 GB / 2 GB	1 GB / 2 GB
1 GB*	1 GB*	512 MB	512 MB	1 GB*	1 GB*	512 MB	512 MB	1 GB / 2 GB	2 GB / 4 GB
1 GB	1 GB	1 GB*	1 GB*	1 GB	1 GB	1 GB*	1 GB*	2 GB / 4 GB	2 GB / 4 GB
2 GB*	2 GB*	512 MB	512 MB	2 GB*	2 GB*	512 MB	512 MB	3 GB / 6 GB	2 GB / 4 GB
2 GB	2 GB	1 GB*	1 GB*	2 GB	2 GB	1 GB*	1 GB*	4 GB / 8 GB	2 GB / 4 GB
2 GB	2 GB	2 GB*	2 GB*	2 GB	2 GB	2 GB*	2 GB*	6 GB / 12 GB	2 GB / 4 GB
4 GB*	4 GB*	512 MB	512 MB	4 GB*	4 GB*	512 MB	512 MB	5 GB / 10 GB	4 GB / 8 GB
4 GB*	4 GB*	1 GB	1 GB	4 GB*	4 GB*	1 GB	1 GB	6 GB / 12 GB	4 GB / 8 GB
4 GB*	4 GB*	2 GB	2 GB	4 GB*	4 GB*	2 GB	2 GB	8 GB / 16 GB	4 GB / 8 GB
4 GB	4 GB	4 GB*	4 GB*	4 GB	4 GB	4 GB*	4 GB*	12 GB / 24 GB	4 GB / 8 GB

\* Indicates a spared single-rank DIMM (512 MB or 1 GB). The entire capacity of this DIMM is reserved for sparing.

Indicates a spared dual-rank DIMM (2 GB and higher). One-half of this DIMM's capacity is reserved for sparing.

## System Memory – PowerEdge M600

You can upgrade your system memory to a maximum of 32 GB by installing 667 MHz registered DDRII fully-buffered DIMMs (FBDs). 512 MB, 1 GB, 2 GB, 4 GB, and 8 GB memory modules are supported.

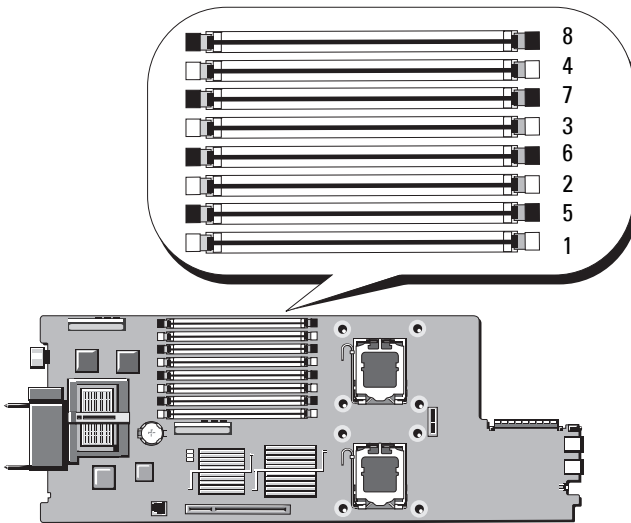
The memory module sockets are divided into two equal branches (0 and 1). Each branch consists of two channels and each channel consists of two memory module sockets:

- Branch 0, Channel 0 consists of slot 1 and slot 5.
- Branch 0, Channel 1 consists of slot 2 and slot 6.
- Branch 1, Channel 2 consists of slot 3 and slot 7.
- Branch 1, Channel 3 consists of slot 4 and slot 8.

The first DIMM socket of each channel has white release tabs.

Figure 3-21 shows the locations of the memory module sockets.

**Figure 3-21. Memory Locations – PowerEdge M600**



### General Memory Module Installation Guidelines – PowerEdge M600

To ensure optimal performance of your system, observe the following guidelines when configuring your system memory:

- Memory modules must be installed in pairs of identically-sized DIMMs. The total number of memory modules must equal two, four, or eight. Six modules are not supported.
- All memory modules in the blade must be identical in speed and technology. The memory modules in each pair must be the same size. For best system performance, all memory modules should be identical memory size, speed, and technology.
- Memory sparing and memory mirroring require eight memory modules of identical size, speed, and technology.  
Memory sparing and memory mirroring cannot be implemented at the same time.

Table 3-14 shows examples of supported memory configurations.

 **CAUTION: Memory module blanks must be installed in unoccupied memory sockets to maintain proper cooling airflow.**

**Table 3-14. Examples of Memory Configurations – PowerEdge M600**

Total Memory	DIMM							
	1	2	3	4	5	6	7	8
1 GB	512 MB	512 MB	blank	blank	blank	blank	blank	blank
2 GB	512 MB	512 MB	512 MB	512 MB	blank	blank	blank	blank
2 GB	1 GB	1 GB	blank	blank	blank	blank	blank	blank
4 GB	512 MB	512 MB	512 MB	512 MB	512 MB	512 MB	512 MB	512 MB
4 GB	1 GB	1 GB	1 GB	1 GB	blank	blank	blank	blank
8 GB	1 GB	1 GB	1 GB	1 GB	1 GB	1 GB	1 GB	1 GB
8 GB	2 GB	2 GB	2 GB	2 GB	blank	blank	blank	blank
16 GB	2 GB	2 GB	2 GB	2 GB	2 GB	2 GB	2 GB	2 GB
16 GB	4 GB	4 GB	4 GB	4 GB	blank	blank	blank	blank
32 GB	4 GB	4 GB	4 GB	4 GB	4 GB	4 GB	4 GB	4 GB

### Non-Optimal Memory Configurations

System performance can be affected if your memory configuration does not conform to the preceding installation guidelines. Your system may issue an error message during start-up stating that your memory configuration is non-optimal.

### Memory Sparing Support – PowerEdge M600

Memory sparing requires eight identical memory modules. The memory sparing feature must also be enabled in the System Setup program, and can be used only if memory mirroring is not enabled.

Table 3-15 shows how memory sparing splits the available and spared memory in each memory module configuration.

**Table 3-15. Memory Sparing Configurations – PowerEdge M600**

DIMMs	Size/Type	Total Memory	Available	Spare
8	512 MB	4 GB	2 GB	2 GB
8	1 GB single-rank	8 GB	4 GB	4 GB
8	2 GB dual-rank	16 GB	12 GB	4 GB
8	4 GB dual-rank	32 GB	24 GB	8 GB

### Memory Mirroring Support – PowerEdge M600

The system supports memory mirroring if eight identical memory modules are installed in the system. Mirroring must be enabled in the System Setup program and can be used only if memory sparing is not enabled. In a mirrored configuration, the total available system memory is one-half of the total installed memory.

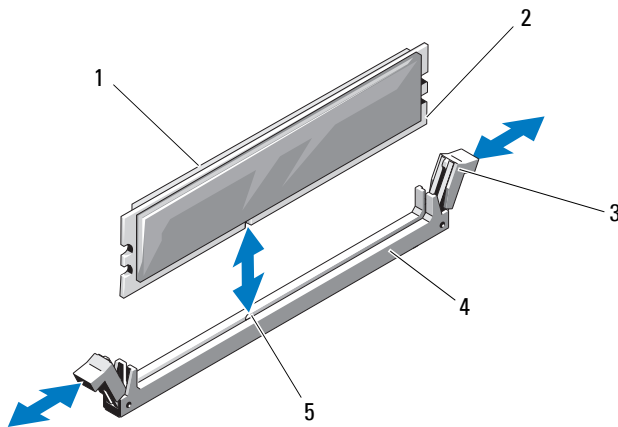


## Installing Memory Modules

**⚠ WARNING:** The memory modules are hot to the touch for some time after the blade has been powered down. Allow time for the memory modules to cool before handling them. Handle the memory modules by the card edges and avoid touching the components.

- 1 Remove the blade. See "Removing a Blade" on page 155.
- 2 Open the blade. See "Opening the Blade" on page 159.
- 3 Locate the memory module sockets. See Figure 7-13 or Figure 7-12.
- 4 *PowerEdge M910 and M905 systems only* - You must slide the system board back in the blade chassis to access memory sockets (B1-B8) and (D1-D8) for M910 and (C1-C4) and (D1-D4) for M905. See step 1 through step 8 in "Removing the System Board" on page 276.
- 5 Press the ejectors on the memory module socket down and out, as shown in Figure 3-22, to allow the memory module to be inserted into the socket.  
If a memory module blank is installed in the socket, remove it.

**Figure 3-22. Installing and Removing a Memory Module or Memory Module Blank**



- |   |               |   |                |
|---|---------------|---|----------------|
| 1 | memory module | 2 | edge connector |
| 3 | ejectors (2)  | 4 | socket         |
| 5 | alignment key |   |                |

- 6 Align the memory module's edge connector with the alignment key on the memory module socket, and insert the memory module in the socket.



**NOTE:** The memory module socket has an alignment key that allows you to install the memory module in the socket in only one way.

- 7 Press down on the memory module with your thumbs to lock the memory module into the socket.

When the memory module is properly seated in the socket, the ejectors on the memory module socket align with the ejectors on the other sockets that have memory modules installed.

- 8 Repeat step 5 through step 7 of this procedure to install the remaining memory modules. See Table 3-14, Table 3-11, or Table 3-12 for sample memory configurations.
- 9 *PowerEdge M910 and M905 systems only* - If you removed the system board to access the memory modules, reinstall the system board.
- 10 Close the blade. See "Closing the Blade" on page 161.
- 11 Install the blade. See "Installing a Blade" on page 158.
- 12 (Optional) Press <F2> to enter the System Setup program, and check the **System Memory** setting on the main **System Setup** screen.  
The system should have already changed the value to reflect the newly installed memory.
- 13 If the value is incorrect, one or more of the memory modules may not be installed properly. Check to ensure that the memory modules are firmly seated in their sockets.
- 14 Run the system memory test in the system diagnostics. See "Running System Diagnostics" on page 325.

## Removing Memory Modules



**WARNING:** The DIMMs are hot to the touch for some time after the blade has been powered down. Allow time for the DIMMs to cool before handling them. Handle the DIMMs by the card edges and avoid touching the DIMM components.


- 1 Remove the blade. See "Removing a Blade" on page 155.
- 2 Open the blade. See "Opening the Blade" on page 159.
- 3 Locate the memory module sockets. See Figure 7-13 or Figure 7-12.

- 4 *PowerEdge M910 and M905 systems only* - You must slide the system board back in the blade chassis to access memory sockets (B1-B8) and (D1-D8) for M910 and (C1-C4) and (D1-D4) for M905. See step 1 through step 9 in "Removing the System Board" on page 276.
- 5 Press down and out on the ejectors on each end of the socket until the memory module pops out of the socket. See Figure 3-22.
- 6 *PowerEdge M910 and M905 systems only* - If you removed the system board to access the memory modules, reinstall the system board.
- 7 Close the blade. See "Closing the Blade" on page 161.
- 8 Install the blade. See "Installing a Blade" on page 158.

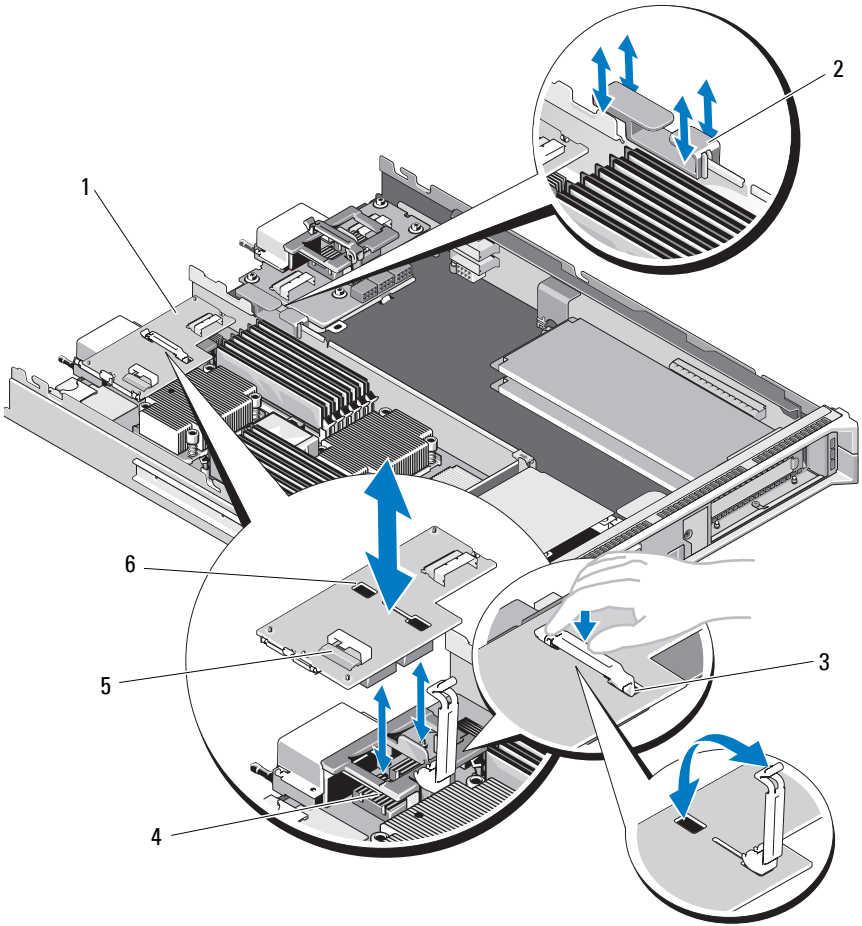
## Mezzanine Interface Card (PowerEdge M610x Only)

The mezzanine interface card is installed on the MEZZ1\_FAB\_C and MEZZ2\_FAB\_B connectors on the system board and provides connectivity between the PCIe expansion-card riser and the system board.

### Removing the Mezzanine Interface Card

- 1 Remove the blade. See "Removing a Blade" on page 155.
- 2 Open the blade. See "Opening the Blade" on page 159.
- 3 Disconnect the data cables from the interface-card connectors.  
To disconnect a data cable, press the release latch on the connector, push inward slightly, then outward to release the cable connector from the interface-card connector.
- 4 Remove the cable management clip from the chassis inner wall. See Figure 3-12.
- 5 Open the card retention latch by pressing the ridged area on the latch with your thumb, and lifting the end of the latch. See Figure 3-23.  
 **NOTE:** Hold the mezzanine interface card by its edges only.
- 6 Lift the interface card straight up from the system board.
- 7 Close the card retention latch.
- 8 Close the blade. See "Closing the Blade" on page 161.

**Figure 3-23. Removing and Installing the Mezzanine Interface Card (PowerEdge M610x Only)**



- |   |                          |   |                              |
|---|--------------------------|---|------------------------------|
| 1 | mezzanine interface card | 2 | cable management clip        |
| 3 | card retention latch     | 4 | mezzanine card connector (2) |
| 5 | data cable connector (2) | 6 | retention latch slot         |

## Installing the Mezzanine Interface Card

- 1 Remove the blade. See "Removing a Blade" on page 155.
- 2 Open the blade. See "Opening the Blade" on page 159.
- 3 Open the card retention latch by pressing the ridged area on the latch with your thumb and lifting the end of the latch. See Figure 3-23.
- 4 If present, remove the connector cover from the interface card bay.



**NOTE:** Hold the mezzanine interface card by its edges only.

- 5 Orient the interface card so that the connectors on the bottom of the interface card align with the corresponding sockets on the system board.
- 6 Insert the end of the retention latch into the retention latch slot on the interface card.
- 7 Lower the interface card into place until it is fully seated and the plastic clip on the outer edge of the card fits over the side of the blade chassis.
- 8 Close the card retention latch to secure the interface card.
- 9 Insert the cable management clip on the chassis inner wall and route the data cables appropriately. See Figure 3-37.
- 10 Connect the data cables to the interface-card connectors.
- 11 Close the blade. See "Closing the Blade" on page 161.
- 12 Install the blade. See "Installing a Blade" on page 158.

## I/O Module Mezzanine Cards

The blades support a variety of optional mezzanine cards. If installed, the mezzanine card(s) must be used in conjunction with a matching I/O module(s). For more information on I/O modules, see "Guidelines for Installing I/O Modules" on page 52.

## Mezzanine Card Installation Guidelines

### Full-Height Blades

Full-height blades support up to four mezzanine cards.



**NOTE:** Even though PowerEdge M610x is a full blade system, only two mezzanine card slots (MEZZ1\_Fab\_C1 and MEZZ2\_FAB\_B1) in the expansion bay are available for use. The other two slots on the system board (MEZZ1\_FAB\_C and MEZZ2\_FAB\_B) are occupied by the mezzanine interface card which provides connectivity between the PCIe expansion-card riser and the system board.

- Slot 1 and slot 3 support Fabric C. They must match the fabric type of the I/O modules installed in I/O module bays C1 and C2.
- Slot 2 and slot 4 support Fabric B. They must match the fabric type of I/O module installed in I/O module bays B1 and B2.



**CAUTION:** For PowerEdge M610x only, a bifurcated mezzanine card (that uses two independent PCIe x4 controllers) cannot be installed in MEZZ1\_FAB\_C1 slot unless either a bifurcated mezzanine card is also installed in MEZZ2\_FAB\_B1 slot or no mezzanine card is installed in MEZZ2\_FAB\_B1. BIOS halts during POST if a non-supported mezzanine card configuration is detected.



**NOTE:** Quad-port Ethernet mezzanine cards are bifurcated.



**NOTE:** The four mezzanine card slots do not need to be fully populated.

If a blade does require support by a particular fabric and only two external I/O port connections are needed, only one mezzanine card is required. For example, a Fibre Channel I/O module in I/O bay C1 or C2 only requires one Fibre Channel mezzanine card in slot 1 or slot 3 in the blade.

If a blade does not require support from a particular fabric, a mezzanine card is not required in either of the corresponding mezzanine card slots.

### *Types of Cards Supported*

- PowerEdge M915 supports SFF mezzanine cards in all four slots. x8 PCIe Gen 2 cards are supported.
- PowerEdge M910 supports SFF mezzanine cards in all four slots. x8 PCIe Gen 1 and x8 PCIe Gen 2 cards are supported.
- PowerEdge M905 and M805 support LFF x8 PCIe Gen 1 mezzanine cards in all four slots.
- PowerEdge M710 supports SFF and LFF mezzanine cards in all four slots. x8 PCIe Gen 1 and x4 PCIe Gen 2 cards are supported.

- PowerEdge M610x supports two small-form factor (SFF) mezzanine cards. x8 PCIe Gen 1 and x8 PCIe Gen 2 cards are supported.

### **Half-Height Blades**

Half-height blades support two mezzanine cards:

- Mezzanine card slot C supports Fabric C. This card must match the fabric type of I/O modules installed in I/O module bays C1 and C2.
- Mezzanine card slot B supports Fabric B. This card must match the fabric type of I/O modules installed in I/O module bays B1 and B2.

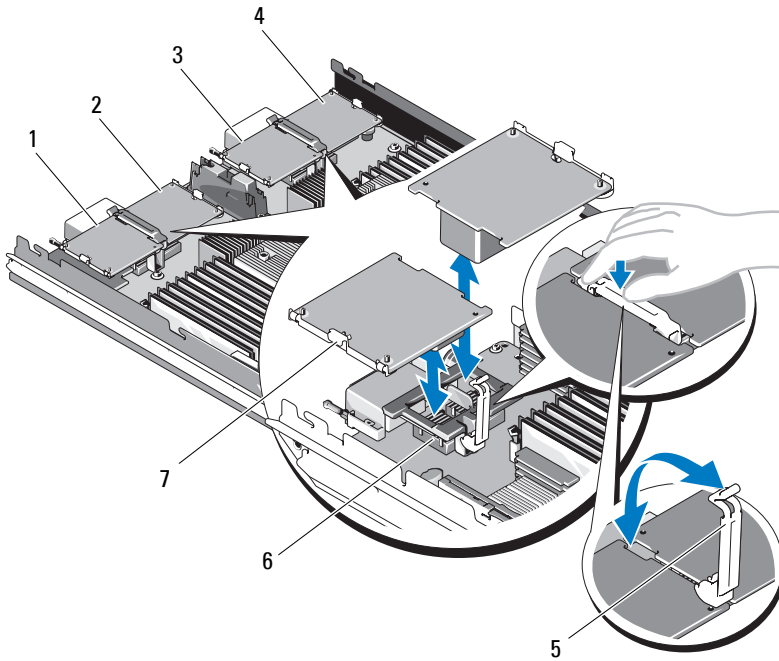
### ***Types of Cards Supported***

- PowerEdge M710HD supports SFF and LFF mezzanine cards. x8 PCIe Gen 1 and x4 PCIe Gen 2 cards are supported.
- PowerEdge M610 supports two SFF or one SFF card and one LFF mezzanine card. x8 PCIe Gen 1 and x4 PCIe Gen 2 cards are supported.
- PowerEdge M605 and M600 support two LFF x8 PCIe Gen 1 mezzanine cards.

### **Installing a Mezzanine Card**

- 1** Remove the blade. See "Removing a Blade" on page 155.
- 2** Open the blade. See "Opening the Blade" on page 159.
- 3** Open the mezzanine card latch by pressing the ridged area on the latch with your thumb and lifting the end of the latch. See Figure 3-24 or Figure 3-25.

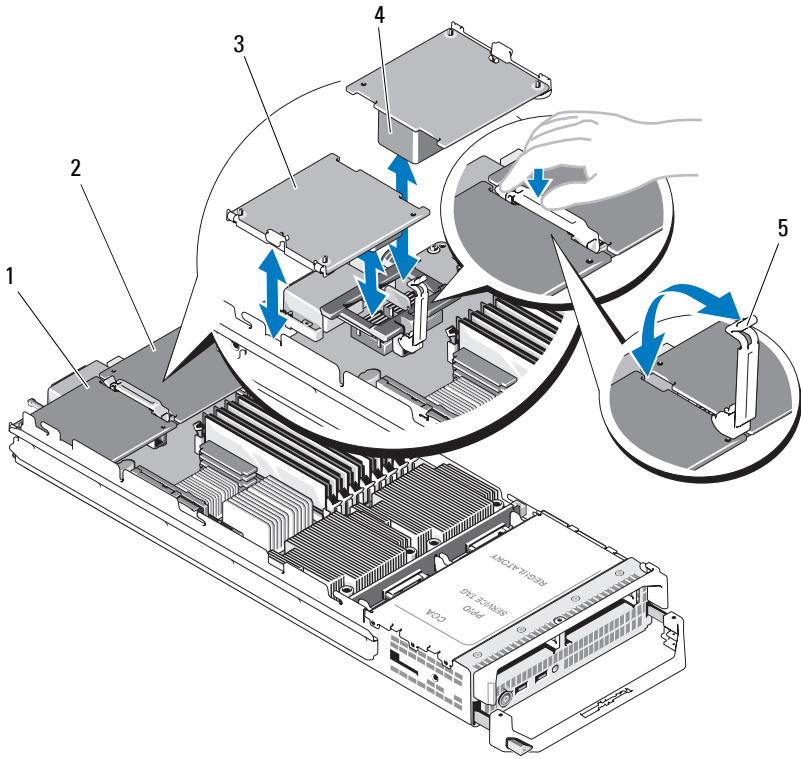
**Figure 3-24. Installing and Removing a Mezzanine Card - Full-Height Blades**



- |   |                                    |   |                                    |
|---|------------------------------------|---|------------------------------------|
| 1 | optional Fabric C mezzanine card 1 | 2 | optional Fabric B mezzanine card 2 |
| 3 | optional Fabric C mezzanine card 3 | 4 | optional Fabric B mezzanine card 4 |
| 5 | retention latch                    | 6 | mezzanine card connector           |
| 7 | mezzanine card                     |   |                                    |




**Figure 3-25. Installing and Removing a Mezzanine Card - Half-Height Blades**



- |   |                              |   |                              |
|---|------------------------------|---|------------------------------|
| 1 | Fabric C mezzanine card slot | 2 | Fabric B mezzanine card slot |
| 3 | mezzanine card               | 4 | mezzanine card connector     |
| 5 | retention latch              |   |                              |

4 If present, remove the connector cover from the mezzanine card bay.

 **NOTE:** Hold the mezzanine card by its edges only.

5 Mezzanine cards are designed to fit in either card slot. Rotate the card to align the connector on the bottom of the mezzanine card with the corresponding socket on the blade board.

- 6 Lower the card into place until it is fully seated and the plastic clip on the outer edge of the card fits over the side of the blade chassis.
- 7 Close the retention latch to secure the mezzanine card.
- 8 Close the blade. See "Closing the Blade" on page 161.
- 9 Install the blade. See "Installing a Blade" on page 158.

### Removing a Mezzanine Card

- 1 Remove the blade. See "Removing a Blade" on page 155.
- 2 Open the blade. See "Opening the Blade" on page 159.
- 3 Open the mezzanine card latch by pressing the ridged area on the latch with your thumb, and lifting the end of the latch. See Figure 3-25.



**NOTE:** Hold the mezzanine card by its edges only.

- 4 Lift up the mezzanine card straight up from the system board.
- 5 Close the retention latch.
- 6 Close the blade. See "Closing the Blade" on page 161.
- 7 Install the blade. See "Installing a Blade" on page 158.

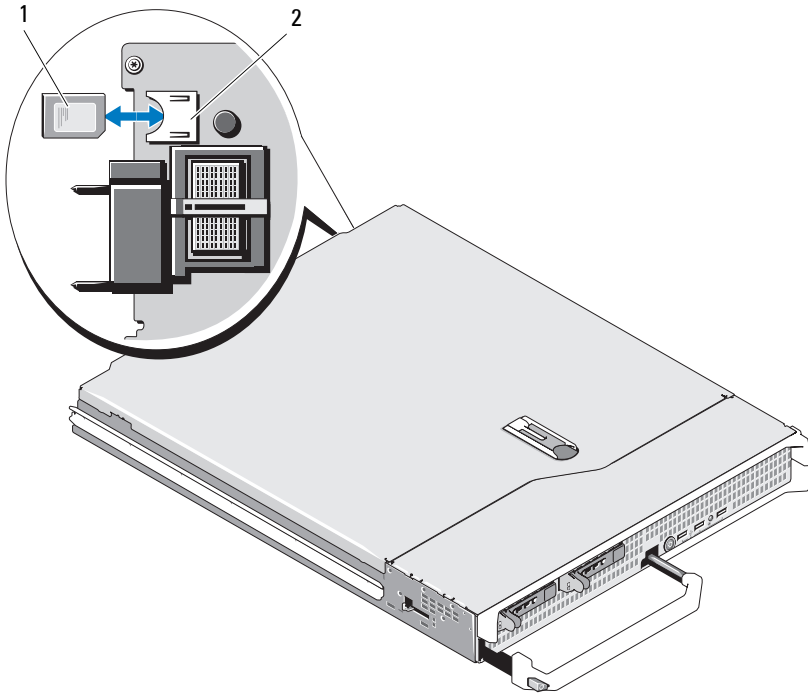
# SD Card

## PowerEdge M905 and M805

In these blades, the SD card is an unmanaged persistent storage card. A hypervisor may be installed using this card.

- 1 Remove the blade. See "Removing a Blade" on page 155.
- 2 Install the SD card in the lower card slot. See Figure 3-26.
- 3 Install the blade. See "Installing a Blade" on page 158.

**Figure 3-26. Installing and Removing an SD Card (PowerEdge M905 and M805)**



1 SD card

2 SD card connector

## PowerEdge M915, M910, M710, M710HD, M610, and M610x

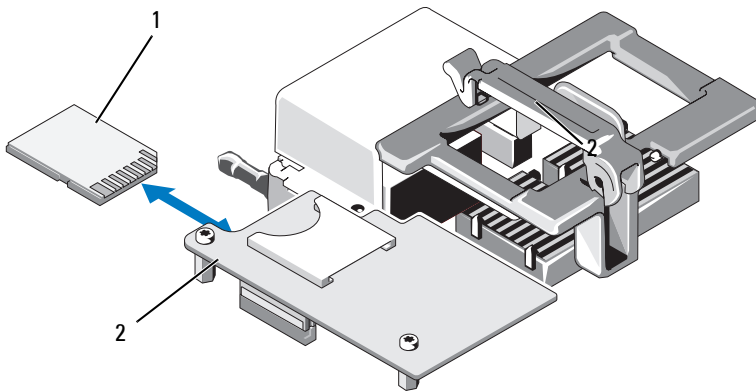
In these blades, the SD card is an unmanaged persistent storage card. A hypervisor may be installed using this card.

**NOTE:** For PowerEdge M915, M910, and M710HD, the iDRAC6 vFLASH card can be set to IDSDM function along with the SD card by setting the **Redundancy** option to **Mirror** mode in the **Integrated Devices** screen of system setup. When the IDSDM function is enabled, the vFlash functionality of the iDRAC6 vFlash card gets disabled.

**NOTE:** In IDSDM (PowerEdge M915, M910, and M710HD only), the SD card in the lower card slot is the primary card (SD1) and the SD card in upper card slot is the secondary card (SD2).

- 1 Remove the blade. See "Removing a Blade" on page 155.
- 2 Install the SD card in the lower card slot. See Figure 3-27.
- 3 Install the blade. See "Installing a Blade" on page 158.


**Figure 3-27. Installing and Removing an SD Card (PowerEdge M915, M910, M710, M710HD, M610, and M610x)**




1 SD card in lower card slot

2 iDRAC6 Enterprise card

## SD vFlash Card (PowerEdge M915, M910, M710, M710HD, M610, and M610x Only)

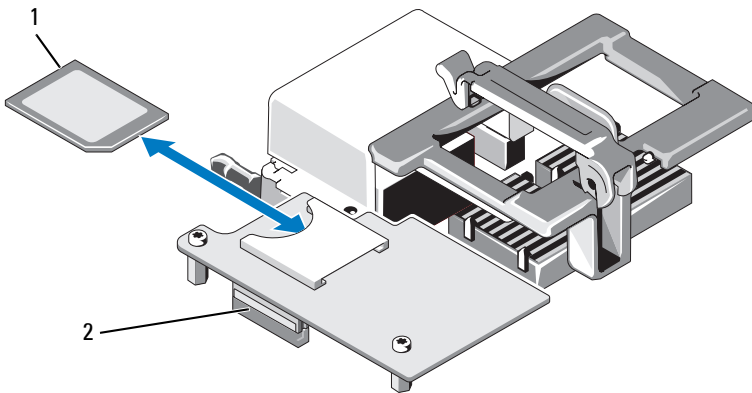
 **NOTE:** For PowerEdge M915, M910 and M710HD, the iDRAC6 vFLASH card can be set to IDSDM function along with the SD card by setting the **Redundancy** option to **Mirror** mode in the **Integrated Devices** screen of system setup. When the IDSDM function is enabled, the vFlash functionality of the iDRAC6 vFlash card gets disabled.

 **NOTE:** In IDSDM (PowerEdge M915, M910, and M710HD only), the SD card in the lower card slot is the primary card (SD1) and the SD card in upper card slot is the secondary card (SD2).

The SD vFlash card plugs into the iDRAC6 Enterprise card at the back corner of the blade.

- 1 Remove the blade. See "Removing a Blade" on page 155.
- 2 Install the SD vFlash card in the upper card slot. See Figure 3-28.
- 3 Install the blade. See "Installing a Blade" on page 158.


**Figure 3-28. Installing and Removing an SD vFlash Card (PowerEdge M915, M910, M710, M710HD, M610, and M610x)**



- 1 SD vFlash card in upper card slot      2 iDRAC6 Enterprise card

# RAID Battery

The information in this section applies only to systems with the optional PERC controller cards without an integral battery backup unit.

 **NOTE:** For PowerEdge M710, M610, and M610x the RAID battery connectors are located on the system board. To locate the connectors for the RAID battery on the system board, see the appropriate figure in "System Board Connectors" on page 338.

## Removing a RAID Battery

- 1 Remove the blade. See "Removing a Blade" on page 155.
- 2 Open the system. See "Opening the Blade" on page 159.
- 3 Press the tab on the RAID battery cable connector and pull the cable connector out of the connector on the storage card. See Figure 3-29.
- 4 Remove the battery.

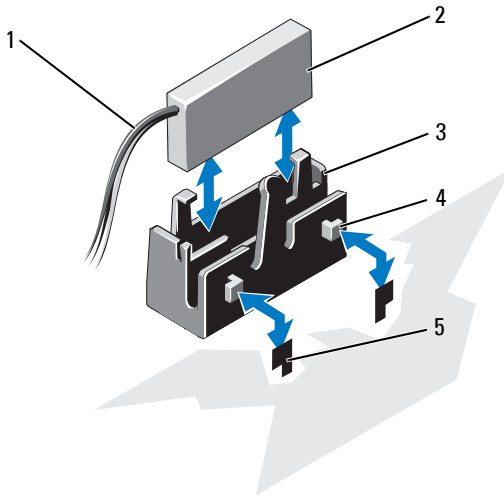
For systems with a battery carrier:

- a Pull the battery carrier release tab, and lift the battery carrier out of the battery-carrier slots on the chassis. See Figure 3-29.
- b Pull back gently on the two tabs holding the RAID battery and lift the RAID battery from the battery carrier. See Figure 3-29.

For PowerEdge M910, slide the battery to free the tabs on the RAID battery from the battery carrier on the system board and lift the RAID battery from the system board (see Figure 3-30).

For systems without a battery carrier (PowerEdge M710, M610, and M610x), slide the battery to free the tabs on the RAID battery from the metal standoffs on the system board and lift the RAID battery from the system board (see Figure 3-31 and Figure 3-32).

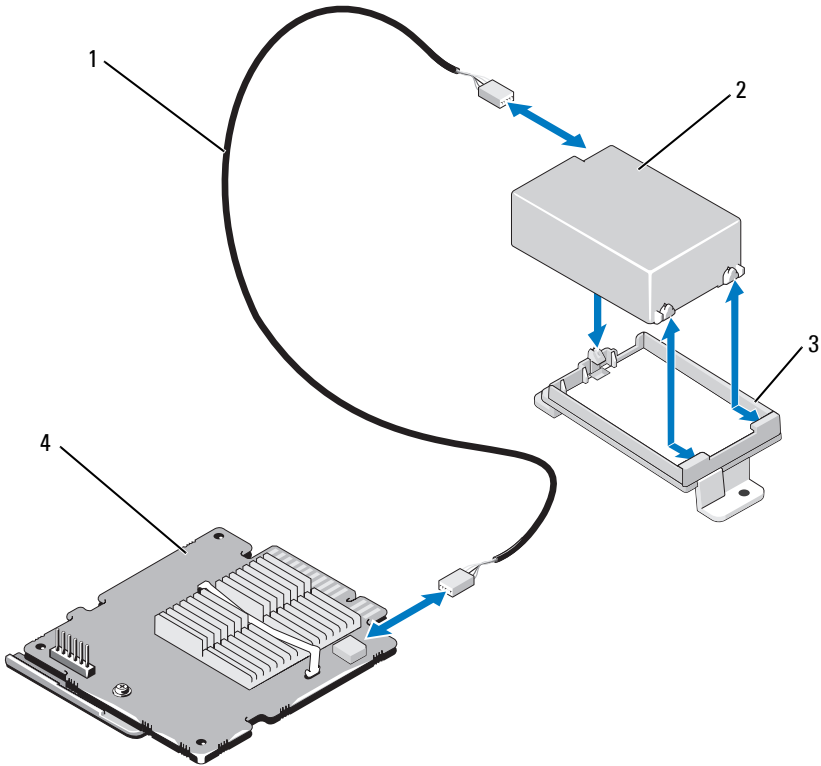
**Figure 3-29. Removing or Installing the RAID Battery**



- 1 RAID battery cable
- 3 battery carrier
- 5 slots (2)

- 2 RAID battery
- 4 tabs (2)

**Figure 3-30. Removing or Installing the RAID Battery (M915 and M910 Only)**

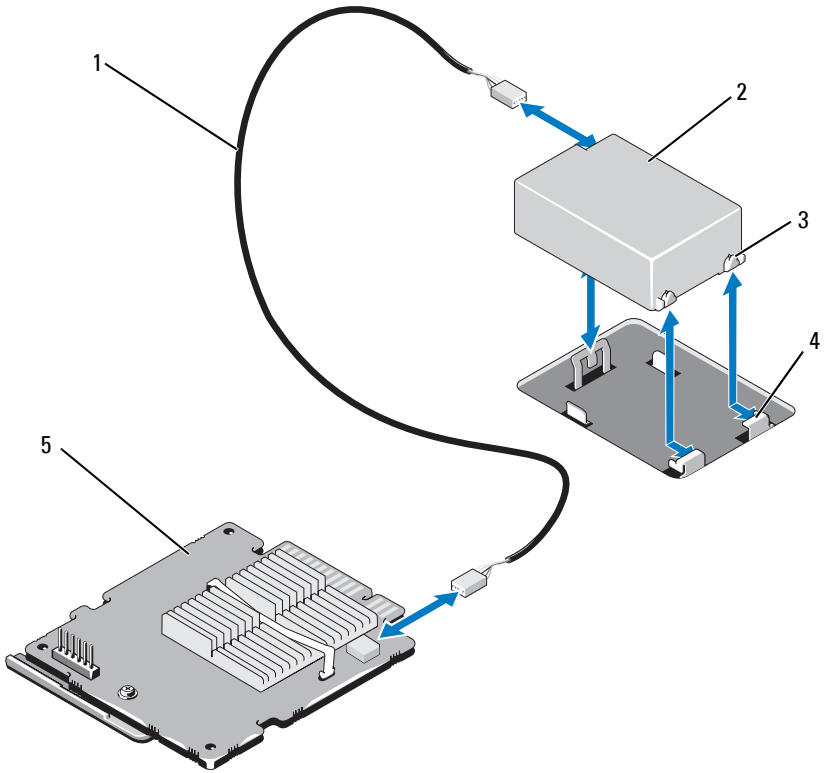


- 1 RAID battery cable
- 3 battery carrier

- 2 RAID battery
- 4 storage controller card



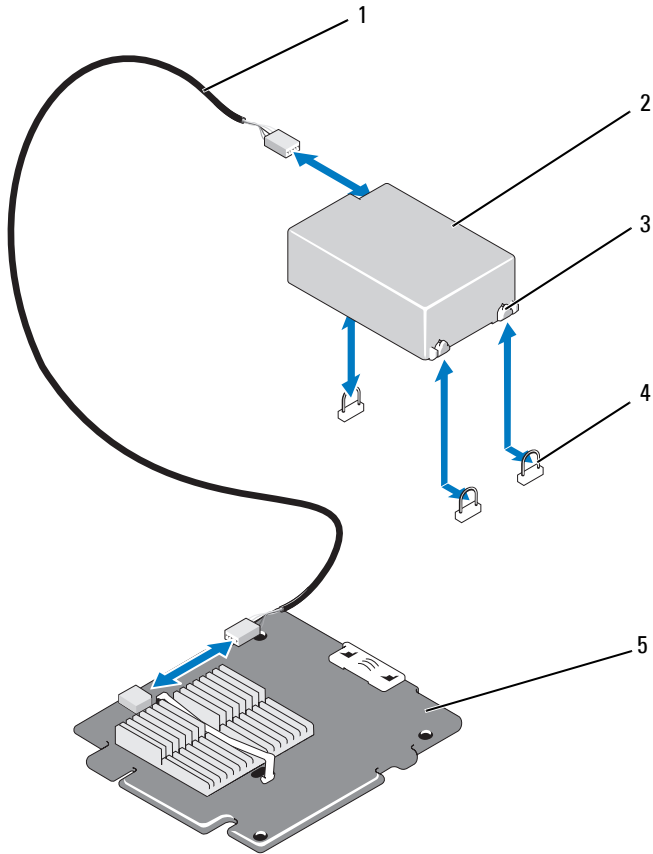
**Figure 3-31. Removing or Installing the RAID Battery (M710 Only)**



- 1 RAID battery cable
- 3 tabs (3)
- 5 storage controller card

- 2 RAID battery
- 4 metal standoffs

**Figure 3-32. Removing or Installing the RAID Battery (PowerEdge M610/M610x Only)**



- 1 RAID battery cable
- 3 tabs (3)
- 5 storage controller card

- 2 RAID battery
- 4 metal standoffs (3)

## Installing the RAID Battery

- 1** Insert the battery.

For systems with a battery carrier:

- a** Insert the RAID battery into the battery carrier. See Figure 3-29.
- b** Align the tabs on the battery carrier with the battery carrier slots on the chassis.
- c** Slide the battery carrier into the battery carrier slots until it locks into place. See Figure 3-29.


For PowerEdge M910, slide the battery in to secure the tabs on the RAID battery in the battery carrier on the system board (see Figure 3-30).

For PowerEdge M710, M610, and M610x, slide the battery in to secure the tabs on the RAID battery to the metal standoffs on the system board (see Figure 3-31 and Figure 3-32).

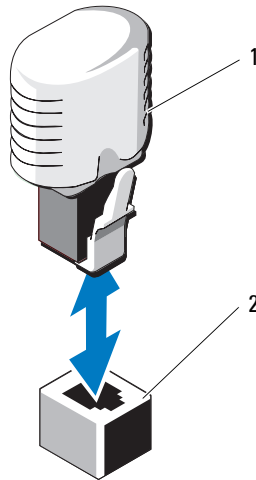
- 2** Connect the battery cable to the connector on the storage card.
- 3** Close the system. See "Closing the Blade" on page 161.
- 4** Install the blade. See "Installing a Blade" on page 158.

## Integrated NIC Hardware Key

Hardware functionality for the blade's integrated NICs is enabled by installing a NIC hardware key in the socket on the system board (see "System Board Connectors" on page 338.)

 **NOTE:** Operating system support is also required for full NIC functionality.

**Figure 3-33. Installing a NIC Hardware Key**



1 NIC hardware key

2 connector on system board

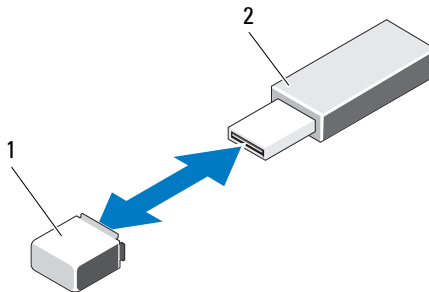
## Internal USB Key (PowerEdge M915, M910, M710, M710HD, M610, and M610x Only)

These blades provide an internal USB connector for a USB flash memory key. The USB memory key can be used as a boot device, security key, or mass storage device. To use the internal USB connector, the **Internal USB Port** option must be enabled in the **Integrated Devices** screen of the System Setup program.

To boot from the USB memory key, you must configure the USB memory key with a boot image, and then specify the USB memory key in the boot sequence in the System Setup program. See "Boot Settings Screen" on page 143. For information on creating a bootable file on the USB memory key, see the user documentation that accompanied the USB memory key.

**△ CAUTION: To avoid interference with other components in the blade, the maximum allowable dimensions of the USB key are 15.9 mm wide x 57.15 mm long x 7.9 mm high.**

**Figure 3-34. Installing a USB Memory Key**



1 USB memory key connector on system board (PowerEdge M915, M915, and M910) or backplane (PowerEdge M710HD, M610, and M610x)

2 USB memory key

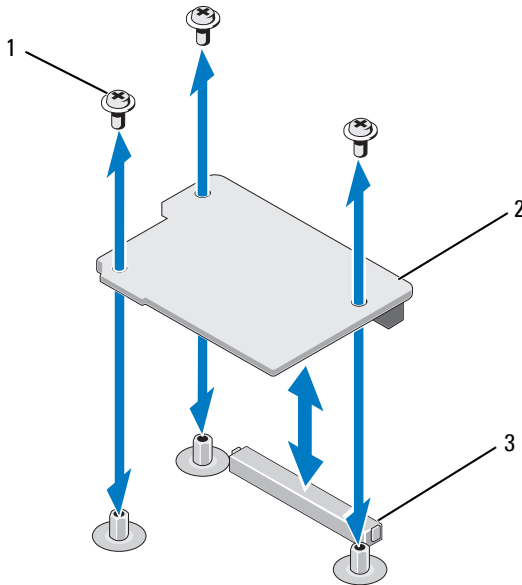
## Network Daughter Card/LOM Riser Card (PowerEdge M915 and M710HD Only)

### Removing the LOM Riser Card

- 1 Remove the blade. See "Removing a Blade" on page 155.
- 2 Open the blade. See "Opening the Blade" on page 159.
- 3 Remove the three screws that secure the LOM riser card to the system board. See Figure 3-35.

- 4 Lift the card from the system board.
- 5 Close the blade. See "Closing the Blade" on page 161.
- 6 Install the blade. See "Installing a Blade" on page 158.

**Figure 3-35. Removing or Installing the Integrated Network Card**



- |   |                          |   |                |
|---|--------------------------|---|----------------|
| 1 | screw (3)                | 2 | LOM riser card |
| 3 | LOM riser card connector |   |                |

### **Installing the LOM Riser Card**


- 1 Remove the blade. See "Removing a Blade" on page 155.
- 2 Open the blade. See "Opening the Blade" on page 159.
- 3 Install the Network Daughter Card:
  - a Lower the card into place until the card connector fits into the corresponding connector on the system board. See Figure 3-35.
  - b Secure the card with the three screws.

- 4 Tighten the screws to secure the card to the system board. See Figure 3-35.
- 5 Close the blade. See "Closing the Blade" on page 161.
- 6 Install the blade. See "Installing a Blade" on page 158.

## Expansion Cards and Expansion-Card Riser (PowerEdge M610x Only)

### Expansion Card Installation Guidelines

Your system supports up to two Generation 2 PCIe expansion cards installed in the connectors on the expansion-card riser. To locate the expansion-card connectors on the expansion-card riser, see Figure 3-39.

- The expansion slots support full-height, full-length, single- or double-width cards.
- Each expansion card can have a power consumption of up to 250 W.
  -  **NOTE:** If only a single PCIe expansion card is installed, it can have power consumption up to 300 W.
- Both the expansion slots are x16 connectors.
- Do not install an expansion card in slot 2 if a double-width card is installed in slot 1.

## Installing an Expansion Card



**CAUTION: Many repairs may only be done by a certified service technician. You should only perform troubleshooting and simple repairs as authorized in your product documentation, or as directed by the online or telephone service and support team. Damage due to servicing that is not authorized by Dell is not covered by your warranty. Read and follow the safety instructions that came with the product.**

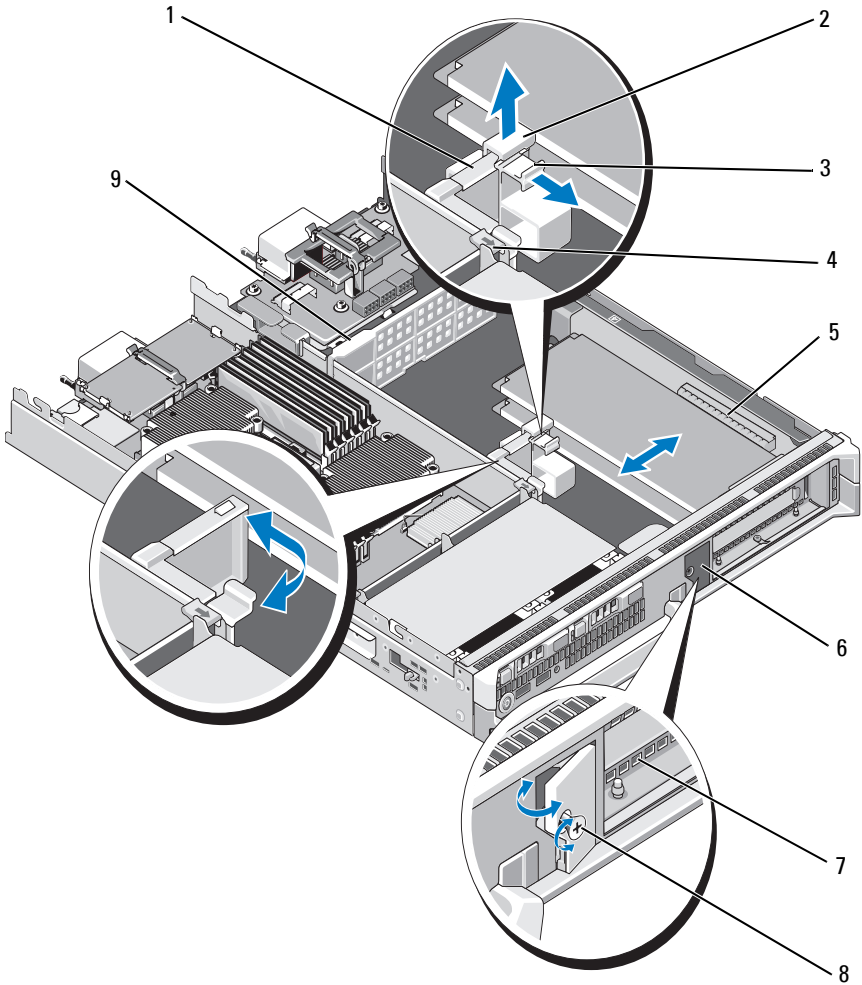
- 1 Unpack the expansion card and prepare it for installation.  
For instructions, see the documentation accompanying the card.
- 2 Open the blade. See "Opening the Blade" on page 159.
- 3 If installed, remove the expansion-card blank:
  - a Loosen the captive screw and open the filler-bracket retention latch by rotating the latch open. See Figure 3-36.
  - b Rotate the expansion-card retention latch away from the blank until it snaps into position under the securing tab. See Figure 3-36.
  - c Grasp the expansion-card blank and remove it from the expansion-card connector. See Figure 3-36.
- 4 Remove the metal filler bracket out of the blade.
- 5 Locate the expansion-card connector on the riser.
- 6 Holding the card by its edges, position the card so that the card-edge connector aligns with the expansion-card connector.
- 7 Insert the card-edge connector firmly into the expansion-card connector until the card is fully seated.

Additionally for NVIDIA M1060 GPGPU card, push the shipping lock up and snap into place. The shipping lock and the locking tab are installed on systems installed with a NVIDIA M1060 GPGPU card.

- 8 Lift the latch-release tab and rotate the expansion-card retention latch toward the expansion card. The retention latch holds the full-height expansion card in position. See Figure 3-36.
- 9 Close the filler-bracket retention latch and tighten the captive screw. See Figure 3-36.



**Figure 3-36. Installing and Removing an Expansion Card (PowerEdge M610x Only)**



- 1 expansion-card retention latch
- 3 locking tab
- 5 expansion-card connector (2)
- 7 filler bracket
- 9 impedance wall

- 2 shipping lock
- 4 securing tab
- 6 filler-bracket retention latch
- 8 captive screw

- 10 Connect the cables to the expansion card. See Figure 3-37 and Figure 3-38.



**NOTE:** Route the data cables connecting the expansion-card riser to the mezzanine interface card through the cable management clip to ensure that the chassis cover slides in without obstruction when you close the blade. See Figure 3-37.

- 11 Close the blade. See "Closing the Blade" on page 161.
- 12 Install the blade. See "Installing a Blade" on page 158.
- 13 Turn on the blade and install any device drivers required for the card as described in the documentation for the card.

## Removing an Expansion Card



**CAUTION:** Many repairs may only be done by a certified service technician. You should only perform troubleshooting and simple repairs as authorized in your product documentation, or as directed by the online or telephone service and support team. Damage due to servicing that is not authorized by Dell is not covered by your warranty. Read and follow the safety instructions that came with the product.

- 1 Open the blade. See "Opening the Blade" on page 159.
- 2 Disconnect all cables from the expansion card to be removed. See Figure 3-37 and Figure 3-38.
- 3 If present, pull the shipping lock upwards and pull the latch-release tab.
- 4 Rotate the expansion-card retention latch away from the blank until it snaps in to position under the latch-release tab. See Figure 3-36.
- 5 Loosen the captive screw and rotate the filler-bracket retention latch open. See Figure 3-36.
- 6 Grasp the expansion card by its edges and carefully remove it from the expansion-card connector.

- 7 If you are removing the card permanently, install a metal filler bracket over the empty expansion slot opening on the chassis:



**NOTE:** You must install a filler bracket over an empty expansion slot to maintain Federal Communications Commission (FCC) certification of the system. The brackets also keep dust and dirt out of the system and aid in proper cooling and airflow inside the system.

- a Loosen the captive screw and rotate the filler-bracket retention latch open as shown in Figure 3-36.
  - b Position the metal filler bracket over the empty expansion slot on the chassis and rotate the filler-bracket retention latch in toward the chassis.
  - c Tighten the captive screw on the filler-bracket retention latch to secure the metal filler bracket to the chassis.
- 8 Close the blade. See "Closing the Blade" on page 161.
  - 9 Install the blade. See "Installing a Blade" on page 158.

## Expansion-Card Riser (PowerEdge M610x Only)

The expansion-card riser supports Generation 2 PCIe expansion cards.

### Removing the Expansion-Card Riser

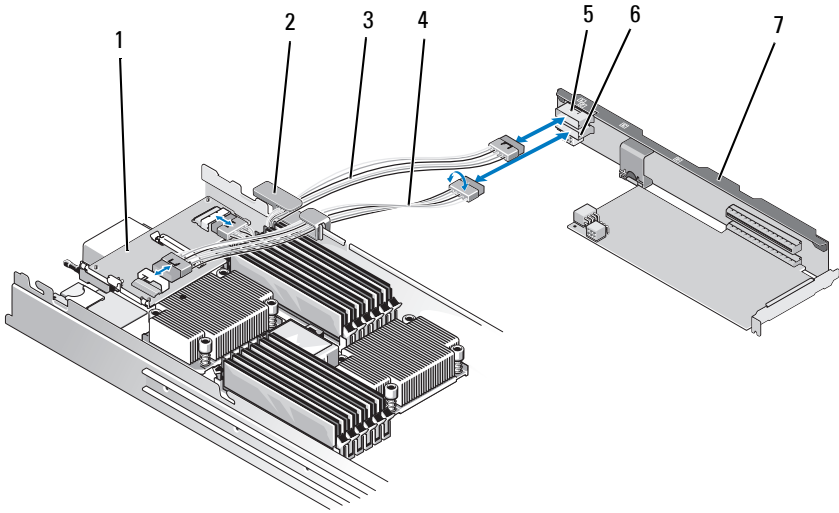


**CAUTION:** Many repairs may only be done by a certified service technician. You should only perform troubleshooting and simple repairs as authorized in your product documentation, or as directed by the online or telephone service and support team. Damage due to servicing that is not authorized by Dell is not covered by your warranty. Read and follow the safety instructions that came with the product.

- 1 Open the blade. See "Opening the Blade" on page 159.
- 2 Disconnect the power and data cables from the riser connectors. See Figure 3-37 and Figure 3-38.

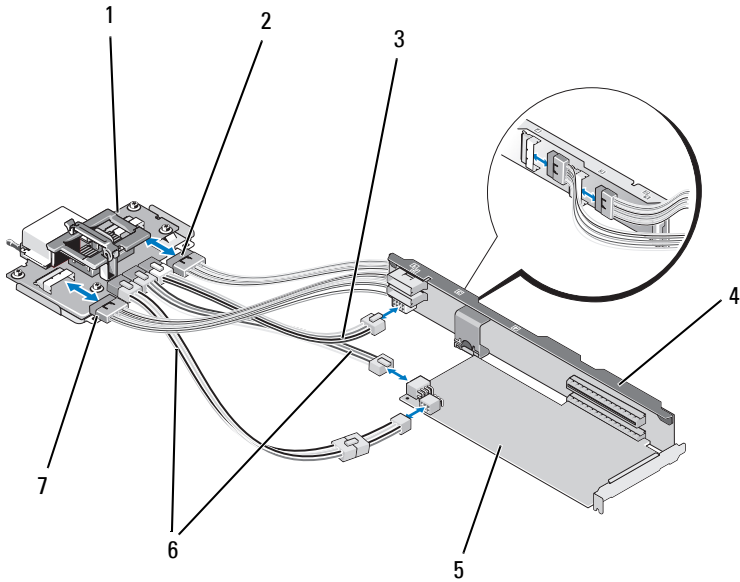
To disconnect the power and data cables, press the release latch on the connector, push inward slightly, then outward to release the cable connector from the board connector.

**Figure 3-37. Installing or Removing Cables Connecting the Expansion-Card Riser to the Mezzanine Interface Card (PowerEdge M610x Only)**



- |   |                          |   |                        |
|---|--------------------------|---|------------------------|
| 1 | mezzanine interface card | 2 | cable management clip  |
| 3 | data cable 2             | 4 | data cable 1           |
| 5 | data cable connector 2   | 6 | data cable connector 1 |
| 7 | expansion-card riser     |   |                        |

**Figure 3-38. Installing or Removing Cables Connecting the Expansion-Card Riser to the Midplane Interface Card (PowerEdge M610x Only)**



- |   |  |   |  |
|---|--|---|--|
| 1 | midplane interface card  | 2 | data cable 4   |
| 3 | power cable connecting midplane interface card to expansion-card riser | 4 | expansion-card riser   |
| 5 | expansion card   | 6 | power cables connecting midplane interface card to expansion cards (2) |

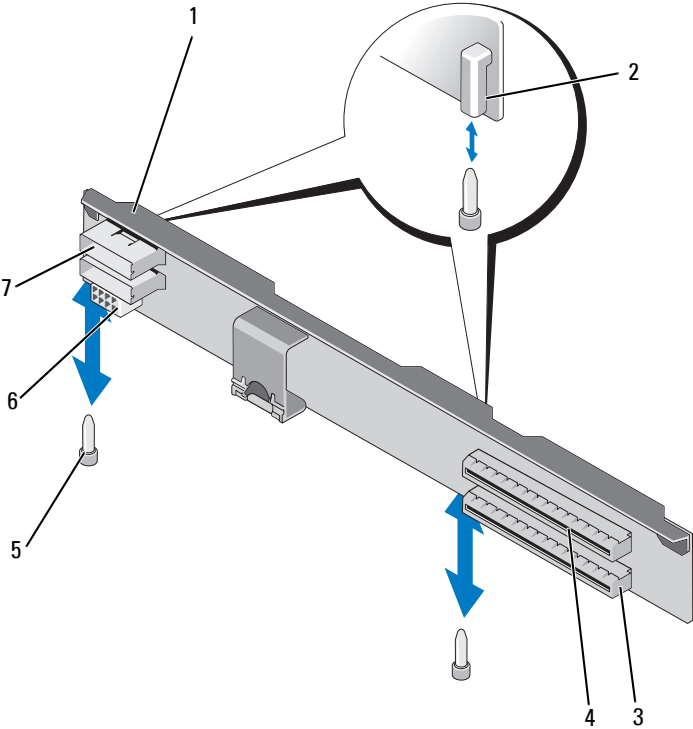
**NOTE:** You may use both power connections depending on the power requirements of the expansion card.

- 7 data cable 3

**3** If installed, remove the expansion card(s) from the expansion-card slot(s). See "Removing an Expansion Card" on page 238.

- 4 Lift up on the left side of the impedance wall to release it from the chassis inner wall, then slide the impedance wall out of the slot on the expansion-card riser. See Figure 3-36.
- 5 Lift the expansion-card riser off the riser guide posts and out of the system. See Figure 3-39.

**Figure 3-39. Installing or Removing the Expansion-Card Riser (PowerEdge M610x Only)**



- |   |  |   |                       |
|---|--|---|-----------------------|
| 1 | expansion-card riser                   | 2 | riser guide (2)       |
| 3 | expansion-card slot 1                  | 4 | expansion-card slot 2 |
| 5 | riser guide post (2)                   | 6 | power cable connector |
| 7 | data cable connector (2 front, 2 back) |   |                       |

## Installing the Expansion-Card Riser

- 1 Align the riser guides on each end of the expansion-card riser with the riser guide posts on the system board and lower the riser into the blade until the riser is fully seated on the system board. See Figure 3-39.
- 2 If applicable, reinstall the expansion card(s). See "Installing an Expansion Card" on page 236.
- 3 Connect the power and data cables to the riser connectors. See Figure 3-37 and Figure 3-38.
- 4 Slide the impedance wall into the slots on the expansion-card riser and the chassis inner wall. See Figure 3-36.
- 5 Close the blade. See "Closing the Blade" on page 161.

## Processors

### Processor Installation Guidelines

#### PowerEdge M915 System

- PowerEdge M915 supports two, four, eight, or twelve core AMD Opteron 6000 series processors only.
- Single-processor configuration is not supported.

#### PowerEdge M910 System

- PowerEdge M910 supports two or four eight core Intel Xeon 7xxx series processors only.
- Single-processor configuration is not supported.

#### PowerEdge M905 System

- PowerEdge M905 supports dual-core or quad-core AMD Opteron 8xxx series processors only.
- Four processors must be installed; dual-processor configurations are not supported.
- Only AMD 8xxx MP series processors are supported.

### PowerEdge M805 System

- PowerEdge M805 supports dual-core or quad-core AMD Opteron 2xxx series processors only.
- Two processors must be installed; single-processor configurations are not supported.
- Hypertransport (HT) bridge cards must be installed in sockets CPU3 and CPU4. See "HT Bridge Card (PowerEdge M905 Only)" on page 262.

### PowerEdge M710, M710HD, M610, M610x, and M600 Systems

- PowerEdge M710, M710HD, M610, M610x, and M600 support dual-core, quad-core, or six-core Intel Xeon processors only.
- Both single and dual-processor configurations are supported.

### PowerEdge M605 System

- PowerEdge M605 supports dual-core or quad-core AMD Opteron 2xxx MP series processors only.
- Both single and dual-processor configurations are supported.

### Removing a Processor

- 1 Remove the blade. See "Removing a Blade" on page 155.
- 2 Open the blade. See "Opening the Blade" on page 159.



**WARNING:** The processor and heat sink can become extremely hot. Be sure the processor has had sufficient time to cool before handling.

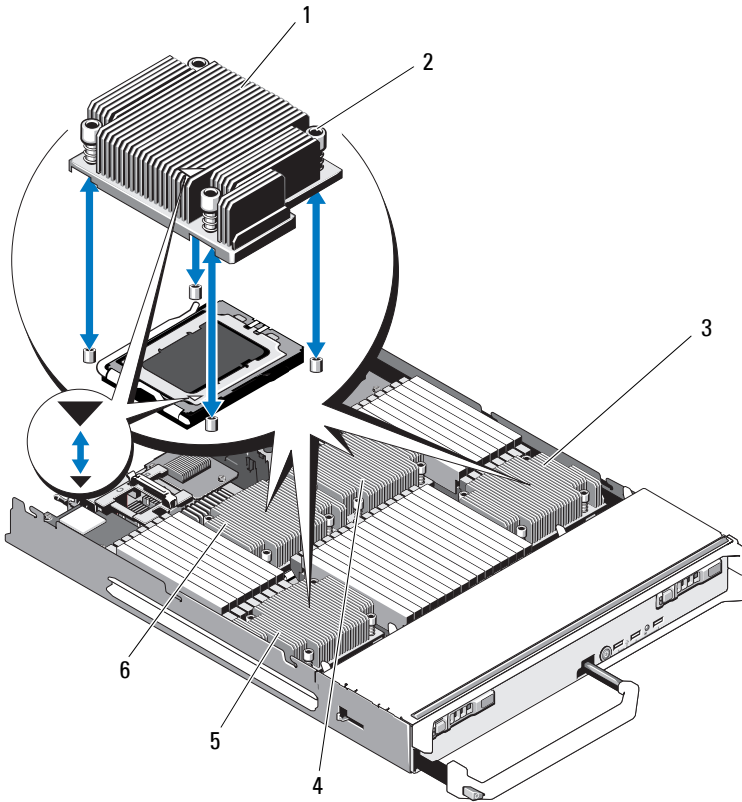


**NOTE:** Never remove the heat sink from a processor unless you intend to remove the processor. The heat sink is necessary to maintain proper thermal conditions.

- 3 Loosen the screws that secure the heat sink to the system board. See the appropriate illustration for your blade.



**Figure 3-40. Installing and Removing the Heat Sink (PowerEdge M915)**



1 heat sink

2 screws (4)

**NOTE:** You must install the heat sink in the orientation shown here.

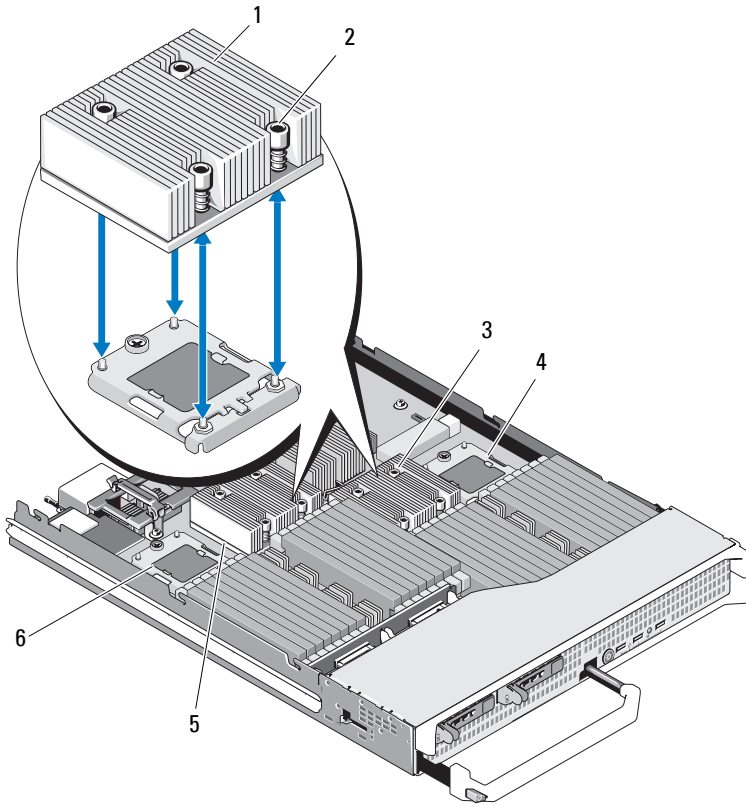
3 processor 4

4 processor 2

5 processor 3

6 processor 1

**Figure 3-41. Installing and Removing the Heat Sink (PowerEdge M910)**



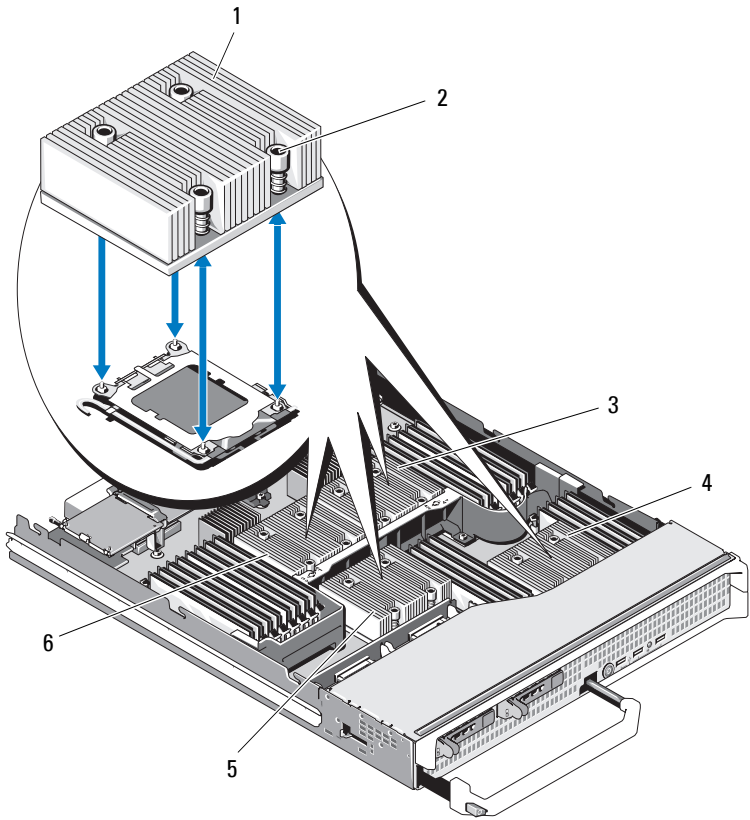
**NOTE:** The above illustration shows the 130 W heat sink. The 95 W / 105 W heat sinks look similar to the heat sink shown in Figure 3-42.

- |   |           |   |            |
|---|-----------|---|------------|
| 1 | heat sink | 2 | screws (4) |
|---|-----------|---|------------|

**NOTE:** You must install the heat sink in the orientation shown here.

- |   |             |   |             |
|---|-------------|---|-------------|
| 3 | socket CPU2 | 4 | socket CPU4 |
| 5 | socket CPU1 | 6 | socket CPU3 |

**Figure 3-42. Installing and Removing the Heat Sink (PowerEdge M905)**



1 heat sink

2 screws (4)

**NOTE:** You must install the heat sink in the orientation shown here.

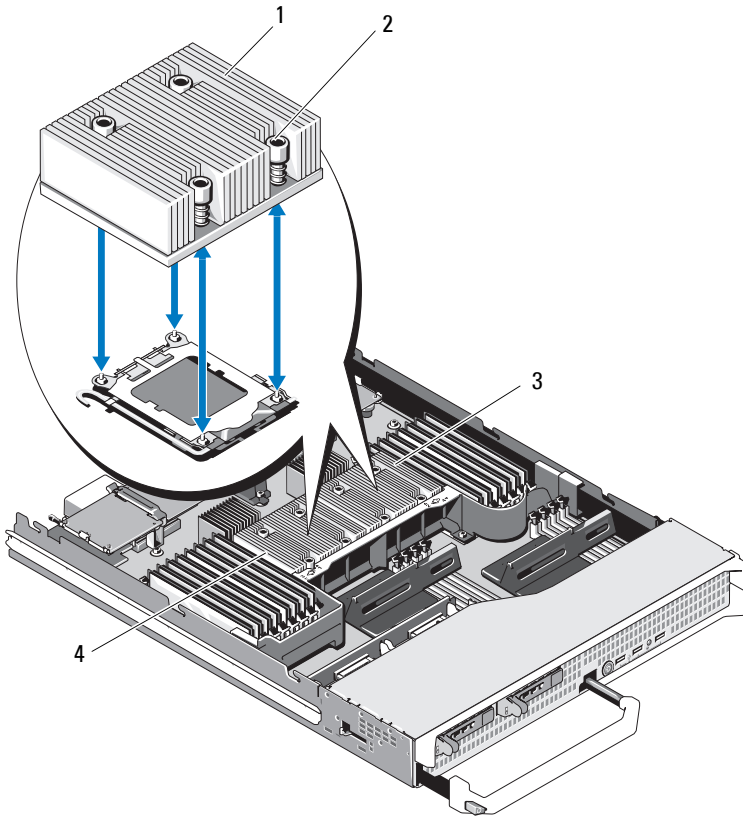
3 socket CPU2

4 socket CPU4

5 socket CPU3

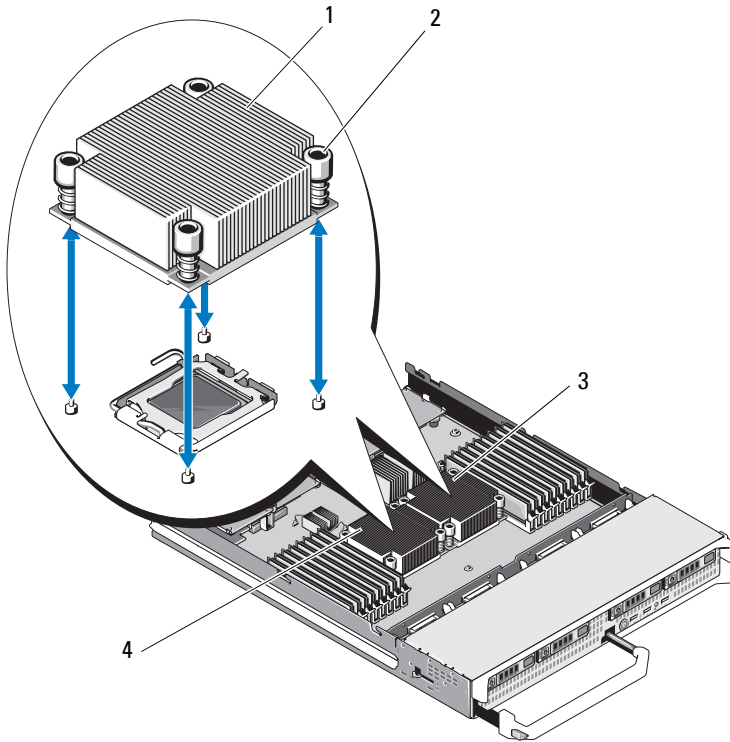
6 socket CPU1

**Figure 3-43. Installing and Removing a Heat Sink (PowerEdge M805)**



- |   |             |   |             |
|---|-------------|---|-------------|
| 1 | heat sink   | 2 | screws (4)  |
| 3 | socket CPU2 | 4 | socket CPU1 |
- NOTE:** You must install the heat sink in the orientation shown here.

**Figure 3-44. Installing and Removing a Heat Sink (PowerEdge M710)**



1 heat sink

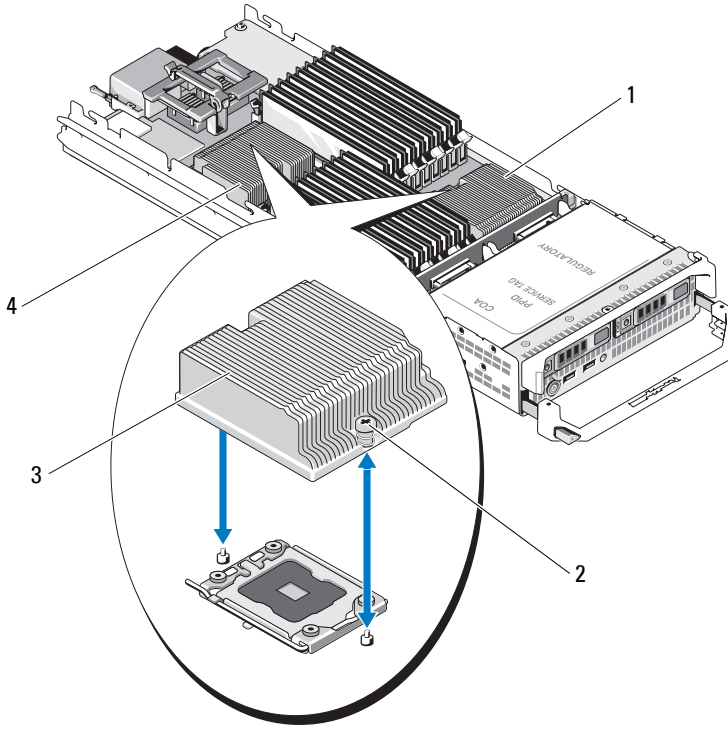
2 screws (4)

**NOTE:** You must install the heat sink in the orientation shown here.

3 socket CPU2

4 socket CPU1

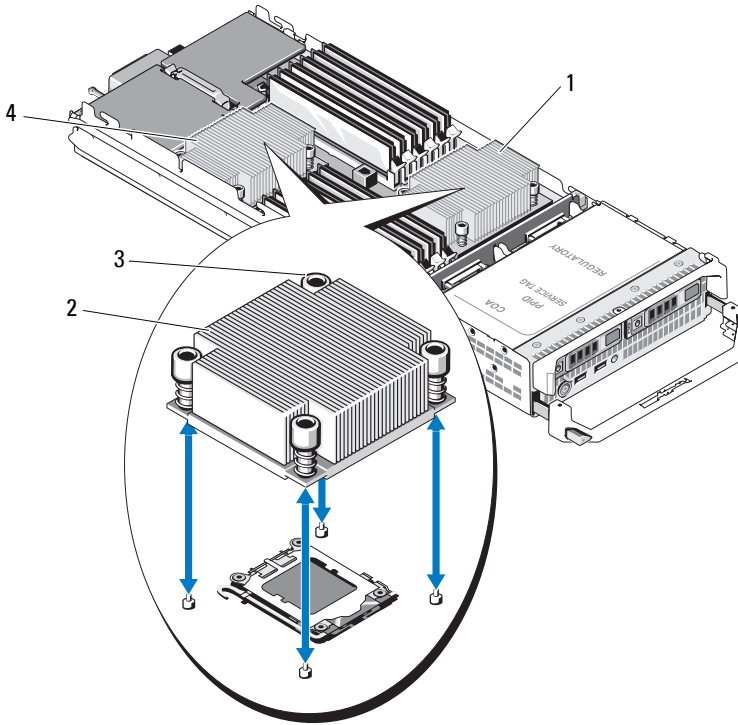
**Figure 3-45. Installing and Removing a Heat Sink (PowerEdge M710HD)**



- |   |             |   |             |
|---|-------------|---|-------------|
| 1 | socket CPU2 | 2 | screws (2)  |
| 3 | heat sink   | 4 | socket CPU1 |

**NOTE:** You must install the heat sink in the orientation shown here.

**Figure 3-46. Installing and Removing a Heat Sink (PowerEdge M610)**



1 socket CPU2

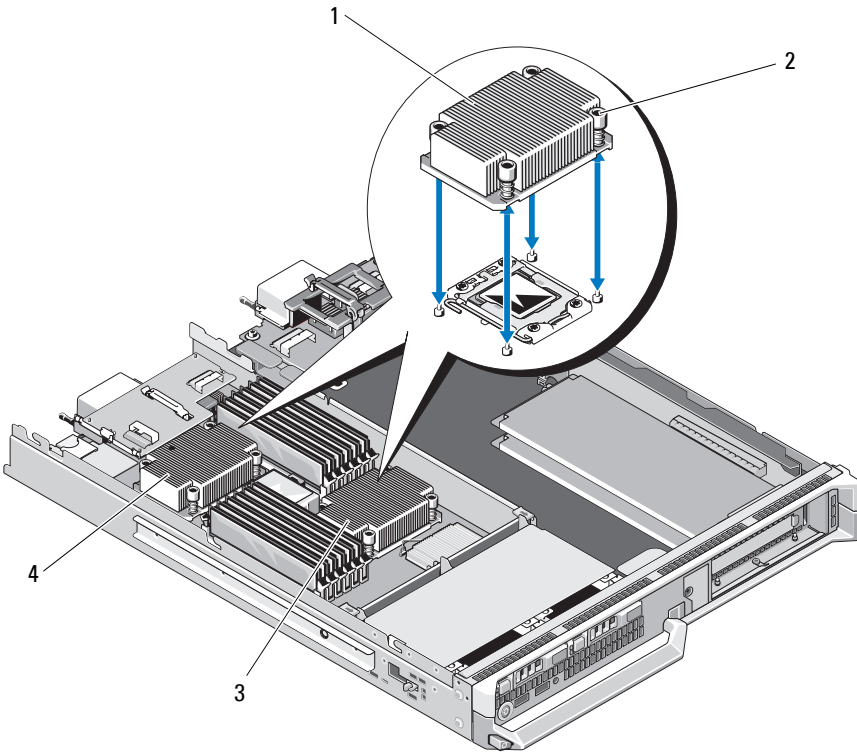
2 heat sink

**NOTE:** You must install the heat sink in the orientation shown here.

3 screws (4)

4 socket CPU1

**Figure 3-47. Installing and Removing a Heat Sink (PowerEdge M610x)**



1 heat sink

2 screws (4)

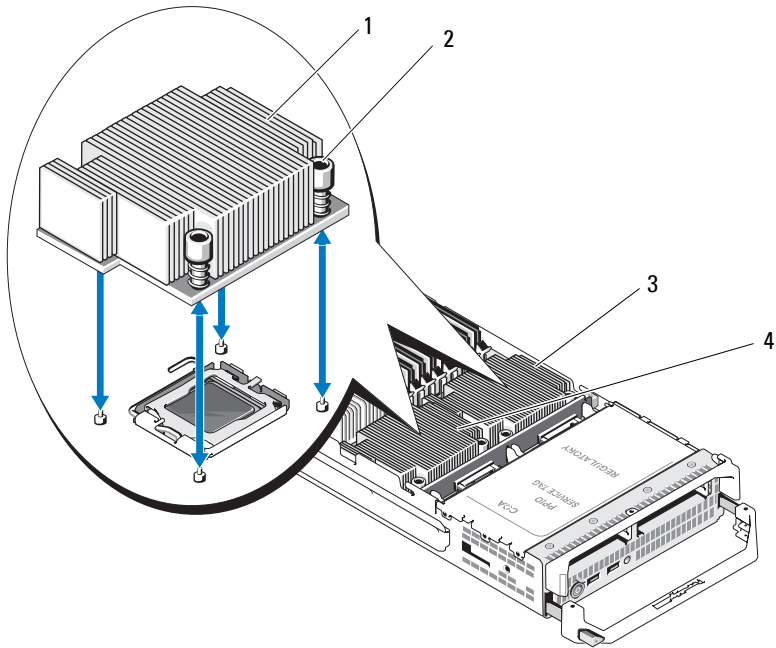
**NOTE:** You must install the heat sink in the orientation shown here.

3 socket CPU2

4 socket CPU1



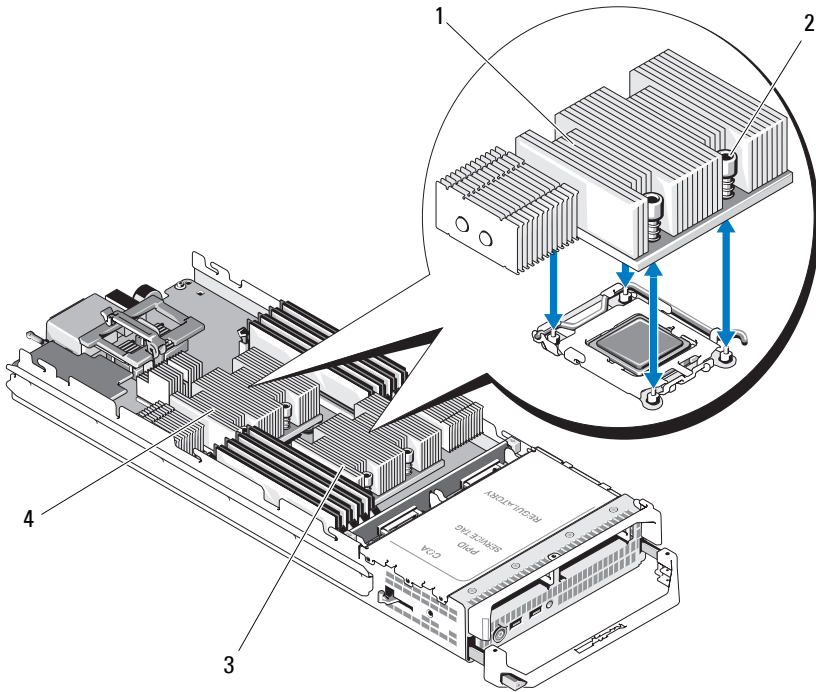
**Figure 3-48. Installing and Removing a Heat Sink (PowerEdge M600)**



- 1 heat sink
- 3 socket CPU1

- 2 screws (4)
- 4 socket CPU2

**Figure 3-49. Installing and Removing a Heat Sink (PowerEdge M605)**



- |   |             |   |             |
|---|-------------|---|-------------|
| 1 | heat sink   | 2 | screws (4)  |
| 3 | socket CPU2 | 4 | socket CPU1 |


**4** Remove the heat sink.

Set the heat sink upside down on the work surface to avoid contaminating the thermal grease.

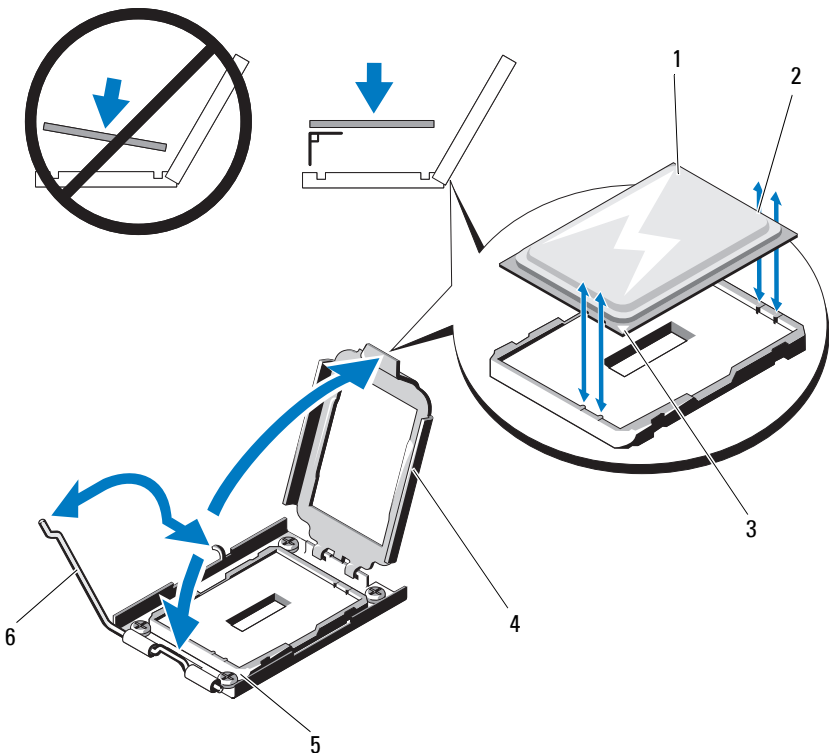
**5** Use a clean, lint-free cloth to remove any thermal grease from the surface of the processor shield.

- 6 For PowerEdge M910, remove the screw to release the processor shield and then lift the processor out of the socket. See Figure 3-51.

For other blades, pull the socket-release lever straight up until the processor is released from the socket. Open the processor shield and then lift the processor out of the socket. See Figure 3-50 (PowerEdge M915), Figure 3-52 (PowerEdge M710, M710HD, M610, M610x, or M600), or Figure 3-53 (PowerEdge M905, M805, or M605).

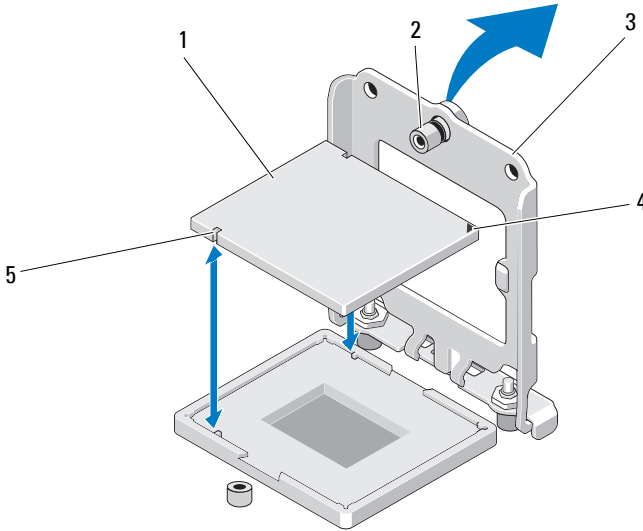
 **NOTE:** Leave the release lever up so that the socket is ready for the new processor.

**Figure 3-50. Installing and Removing the Processor (PowerEdge M915)**



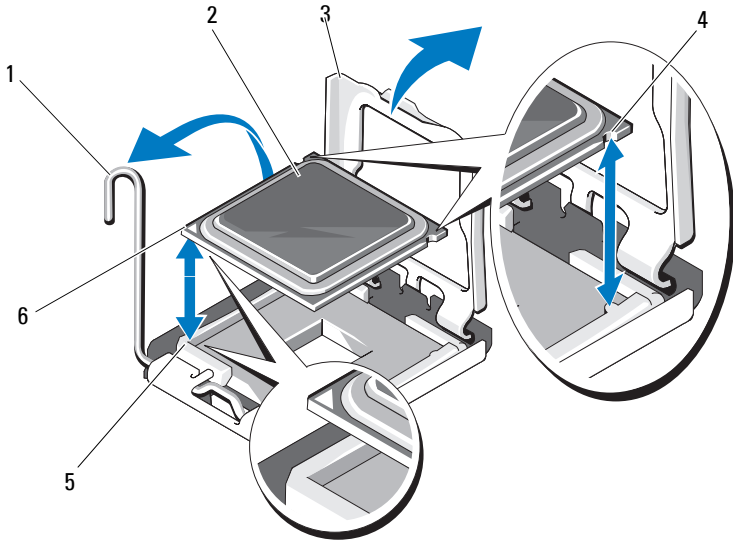
- |   |                           |   |                          |
|---|---------------------------|---|--------------------------|
| 1 | processor                 | 2 | notch in processor screw |
| 3 | pin-1 corner of processor | 4 | processor shield         |
| 5 | pin-1 corner of socket    | 6 | socket-release lever     |

**Figure 3-51. Installing and Removing an Intel Processor (PowerEdge M910)**



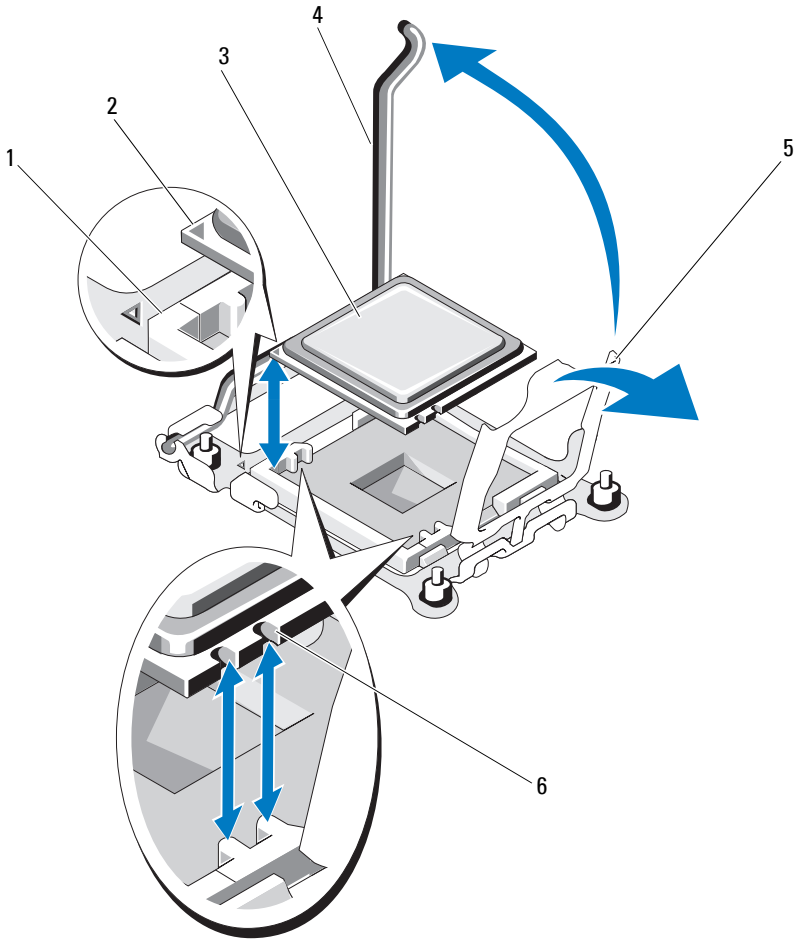
- |   |                    |   |                        |
|---|--------------------|---|------------------------|
| 1 | processor          | 2 | screw                  |
| 3 | processor shield   | 4 | pin-1 corner of socket |
| 5 | notch in processor |   |                        |

**Figure 3-52. Installing and Removing an Intel Processor (PowerEdge M710, M710HD, M610, M610x, or M600)**



- |   |                        |   |                           |
|---|------------------------|---|---------------------------|
| 1 | socket-release lever   | 2 | processor                 |
| 3 | processor shield       | 4 | notch in processor        |
| 5 | pin-1 corner of socket | 6 | pin-1 corner of processor |

**Figure 3-53. Installing and Removing an AMD Processor (PowerEdge M905, M805, or M605)**



- 1 pin-1 corner of socket
- 2 pin-1 corner of processor
- 3 processor
- 5 processor shield

- 4 socket-release lever
- 6 notch in processor

## Installing a Processor

- 1 If you are adding a processor to an unoccupied socket, perform the following steps first:



**NOTE:** If you are installing just one processor, it must be installed in socket CPU1. See Figure 7-13 or Figure 7-12.

- a Remove the processor filler blank.
- b Lift the plastic processor socket cover from the socket.
- c For PowerEdge M910, remove the screw securing the processor shield.  
For other blades, unlatch and rotate the socket-release lever 90 degrees upward and ensure that the socket-release is fully open during processor install.
- d Lift the processor shield.



**CAUTION: Positioning the processor incorrectly can permanently damage the processor and the system board when you turn it on. Be careful not to bend the pins on the LGA socket.**

- 2 Install the processor in the socket. See Figure 3-50 (PowerEdge M915), Figure 3-51 (PowerEdge M910), Figure 3-52 (PowerEdge M710, M710HD, M610, M610x, or M600), or Figure 3-53 (PowerEdge M915, M905, M805, or M605).
  - a Identify the pin-1 corner of the processor by locating the tiny gold triangle on one corner of the processor. Place this corner in the same corner of the ZIF socket identified by a corresponding triangle on the system board. Align the pin-1 corner of the processor with the pin-1 corner of the ZIF socket. See Figure 3-50 (PowerEdge M915), Figure 3-51 (PowerEdge M910), Figure 3-52 (PowerEdge M710, M710HD, M610, M610x, or M600), or Figure 3-53 (PowerEdge M905, M805, or M605).
  - b With the pin-1 corners of the processor and socket aligned, set the processor lightly in the socket.  
Because the system uses a ZIF processor socket, do not use force. When the processor is positioned correctly, it drops down into the socket with minimal pressure.
  - c Close the processor shield.





- 7 Run the system diagnostics to verify that the new processor operates correctly.  
See "Running System Diagnostics" on page 325 for information about running the diagnostics and troubleshooting processor problems.
- 8 Update the system BIOS.

### **FlexMem Bridge (PowerEdge M910 Only)**

A FlexMem bridge must be installed in the third or fourth CPU sockets on the PowerEdge M910 system board to support two-processor configurations. With FlexMem bridges installed, processor 1 can access DIMMs assigned to processor socket 3 and processor 2 can access DIMMs assigned to processor socket 4.

Consequently, if you replace the system board, you must transfer the FlexMem bridge to the replacement planar.

#### **Removing a FlexMem Bridge**

- 1 Remove the blade. See "Removing a Blade" on page 155.
- 2 Open the blade. See "Opening the Blade" on page 159.
- 3 Remove the single screw securing the processor shield. See Figure 3-51.
- 4 Open the processor shield and then lift the FlexMem Bridge out of the socket.

#### **Installing a FlexMem Bridge**

- 1 Perform the following steps to prepare the socket on the new system board:
  - a Remove the processor filler blank.
  - b Lift the plastic processor socket cover from the socket.
  - c Remove the securing screw and lift the processor shield.

- 2 Install the FlexMem Bridge in the socket.



**CAUTION: Positioning the card incorrectly can permanently damage the card and the system board when you turn on the system. Be careful not to bend the pins on the LGA socket.**

- a Identify the pin-1 corner of the card by locating the tiny gold triangle on one corner of the card. Place this corner in the same corner of the ZIF socket identified by a corresponding triangle on the system board.
  - b With the pin-1 corners of the card and socket aligned, set the processor lightly in the socket.  
Because the system uses a ZIF processor socket, do not use force. When the card is positioned correctly, it drops down into the socket with minimal pressure. See Figure 3-51.
  - c Close the processor shield.
  - d Tighten the screw to secure the processor shield.
- 3 Close the blade. See "Closing the Blade" on page 161.
  - 4 Install the blade. See "Installing a Blade" on page 158.

### **HT Bridge Card (PowerEdge M905 Only)**

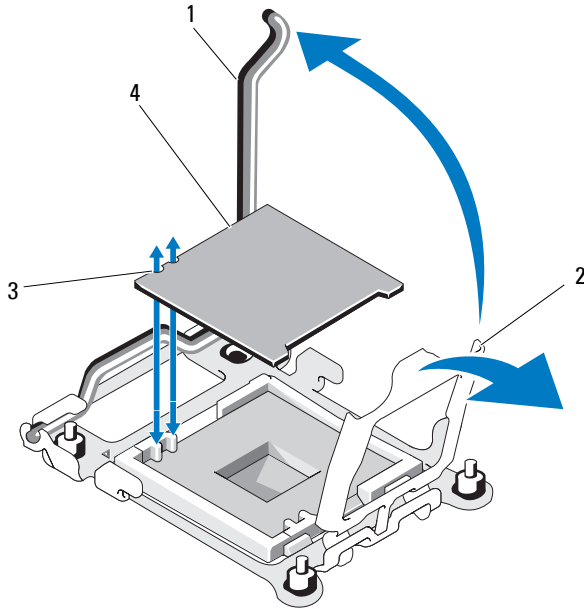
An HT (hypertransport) bridge card must be installed in the third and fourth CPU sockets on the PowerEdge M905 system board.

Consequently, if you replace the system board, you must transfer the HT bridge cards to the replacement planar.

#### **Removing an HT Bridge Card**

- 1 Remove the blade. See "Removing a Blade" on page 155.
- 2 Open the blade. See "Opening the Blade" on page 159.
- 3 Pull the socket-release lever straight up until the bridge card is released from the socket. See Figure 3-54.
- 4 Open the processor shield and then lift the card out of the socket.

**Figure 3-54. Installing and Removing an HT Bridge Card (PowerEdge M905 Only)**



- 1 socket-release lever
- 3 notch in card

- 2 processor shield
- 4 HT bridge card

## Installing an HT Bridge Card

- 1 Perform the following steps to prepare the two sockets on the new system board:
  - a Remove the processor filler blank.
  - b Lift the plastic processor socket cover from the socket.
  - c Unlatch and rotate the socket-release lever 90 degrees upward.
  - d Lift the processor shield.
  - e Repeat step a through step d to prepare the second processor socket.
- 2 Install the bridge card in the socket. See Figure 3-54.



**CAUTION: Positioning the card incorrectly can permanently damage the card and the system board when you turn the system on. Be careful not to bend the pins on the LGA socket.**

- a Identify the pin-1 corner of the card by locating the tiny gold triangle on one corner of the card. Place this corner in the same corner of the ZIF socket identified by a corresponding triangle on the system board.
  - b Ensure that the socket-release lever is fully open.
  - c With the pin-1 corners of the card and socket aligned, set the processor lightly in the socket.

Because the system uses a ZIF processor socket, do not use force. When the card is positioned correctly, it drops down into the socket with minimal pressure.
  - d Close the processor shield.
  - e Rotate the socket release lever down until it snaps into place, securing the card.
- 3 Close the blade. See "Closing the Blade" on page 161.
  - 4 Install the blade. See "Installing a Blade" on page 158.

# Blade System Board NVRAM Backup Battery

The NVRAM backup battery is a 3.0 V, coin-cell battery.

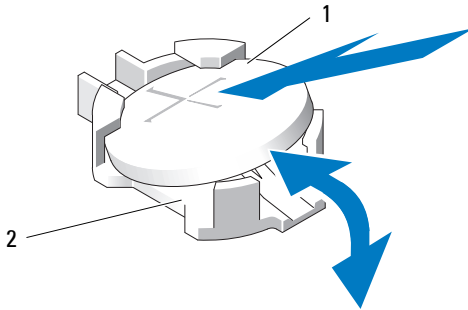
## Removing and Installing the NVRAM Backup Battery



**WARNING:** There is a danger of a new battery exploding if it is incorrectly installed. Replace the battery only with the same or equivalent type recommended by the manufacturer. Discard used batteries according to the manufacturer's instructions. See the safety instructions that came with your system for additional information.

- 1 Remove the blade. See "Removing a Blade" on page 155.
- 2 Open the blade. See "Opening the Blade" on page 159.
- 3 *If you are replacing the battery in a PowerEdge M915, M910, M905, M805, M710HD, M610x, or M605 system, you must remove the system board to access the battery. See "Blade System Board" on page 276.*
- 4 Remove the battery by lifting it straight up from its connector. See Figure 3-55.  
See Figure 7-1 (PowerEdge 915), Figure 7-2 (PowerEdge 910), Figure 7-3 (PowerEdge M905), Figure 7-4 (PowerEdge M805), Figure 7-5 (PowerEdge M710), Figure 7-6 (PowerEdge M710HD), Figure 7-7 (PowerEdge M610), Figure 7-8 (PowerEdge M610x), Figure 7-12 (PowerEdge M605), or Figure 7-13 (PowerEdge M600) to locate the battery on the blade board.
- 5 Install the new battery with the side labeled "+" facing up. See Figure 3-55.

**Figure 3-55. Replacing the NVRAM Backup Battery**



1 "+" side of battery

2 battery connector

- 6 If you removed the system board to replace the battery, reinstall the board now. See "Blade System Board" on page 276.
- 7 Close the blade. See "Closing the Blade" on page 161.
- 8 Install the blade. See "Installing a Blade" on page 158.
- 9 Enter the System Setup program to confirm that the battery is operating properly. See "Using the System Setup Program" in your *User's Guide*.
- 10 Enter the correct time and date in the System Setup program's **Time** and **Date** fields.
- 11 Exit the System Setup program.
- 12 To test the newly installed battery, remove the blade for at least an hour.
- 13 After an hour, reinstall the blade.
- 14 Enter the System Setup program and if the time and date are still incorrect, see "Getting Help" on page 361 for instructions about obtaining technical assistance.

## Hard Drives

- PowerEdge M915 supports two 2.5 inch SAS or SSD hard-disk drives.
- PowerEdge M910 supports up to two 2.5 inch SAS, SATA, or solid-state disk (SSD) hard drives.
- PowerEdge M905 and M805 support one or two 2.5 inch SAS hard-disk drives.
- PowerEdge M710 supports one to four 2.5 inch SAS hard drives.
- PowerEdge M710HD supports one or two 2.5 inch SAS or SSD hard drives.
- PowerEdge M610, M610x, M605, and M600 support one or two 2.5 inch SATA hard drives, one or two 2.5 inch SAS hard drives, or one or two SSD hard drives.



**NOTE:** SAS and SATA hard drives cannot be mixed within a blade.



**NOTE:** Hot-swap operation is supported if an optional RAID controller card is installed.



**NOTE:** SATA hard drives are not hot swappable with the SATA repeater daughter card.

### Hard Drive Installation Guidelines

- If a RAID controller storage card is installed, the blade supports hot-swappable drive removal and installation.
- If less than the maximum number of hard drives are installed, hard-drive blanks must be installed to maintain proper cooling airflow.

### Installing a Hard Drive



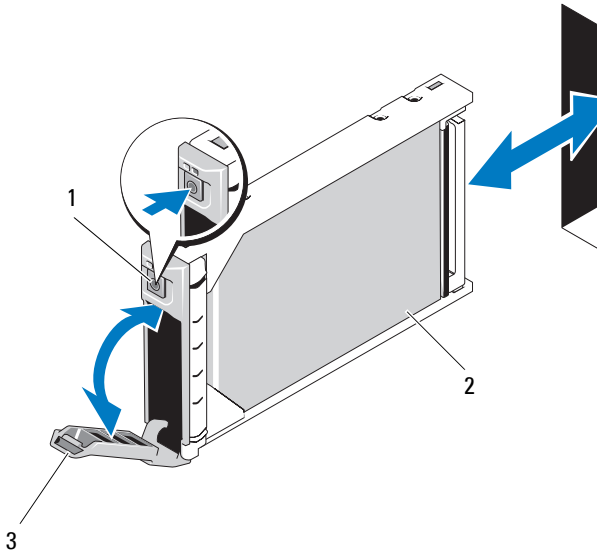
**NOTE:** When a replacement hot-swappable hard drive is installed and the blade is powered on, the hard drive automatically begins to rebuild. Make absolutely sure that the replacement hard drive is blank or contains data that you wish to have over-written. Any data on the replacement hard drive is immediately lost after the hard drive is installed.



**NOTE:** Not all operating systems support hot-swappable drive installation. See the documentation supplied with your operating system.

- 1 Open the hard-drive carrier handle. See Figure 3-56.

**Figure 3-56. Installing a Hard Drive**



- 1 release button
- 2 hard drive
- 3 carrier handle

- 2 Insert the hard-drive carrier into the drive bay. Carefully align the channel on the hard-drive carrier with the appropriate drive slot on the blade.
- 3 Push the drive carrier into the slot until the handle makes contact with the blade.
- 4 Rotate the carrier handle to the closed position while pushing the carrier into the slot until it locks into place.

The status LED indicator displays a steady green light if the drive is installed correctly. The drive carrier LED green indicator flashes as the drive rebuilds.



## Removing a Hard Drive



**NOTE:** Not all operating systems support hot-swappable drive installation. See the documentation supplied with your operating system.

- 1 Take the hard drive offline and wait until the hard-drive indicator codes on the drive carrier signal that the drive may be removed safely. See Figure 1-14.

When all indicators are off, the drive is ready for removal.

See your operating system documentation for more information on taking the hard drive offline.

- 2 Open the hard-drive carrier handle to release the drive. See Figure 3-56.
- 3 Slide the hard drive out until it is free of the drive bay.

If you are permanently removing the hard drive, install a blank insert.

## Shutdown Procedure for Servicing a Hard Drive



**NOTE:** This section applies only to situations where the blade must be powered down to service a hard drive. In many situations, the hard drive can be serviced while the blade is powered on.

If you need to power off the blade to service a hard drive, wait 30 seconds after the blade's power indicator turns off before removing the hard drive. Otherwise, the hard drive may not be recognized after the hard drive is reinstalled and the blade is powered on again.

## Configuring the Boot Drive

The drive or device from which the system boots is determined by the boot order specified in the System Setup program. See "Using the System Setup Program and UEFI Boot Manager" on page 137.

## Removing a Hard Drive From a Hard-Drive Carrier

Remove the four screws from the slide rails on the hard-drive carrier and separate the hard drive from the carrier. See Figure 3-57.

## Installing a Hard Drive in a Hard-Drive Carrier

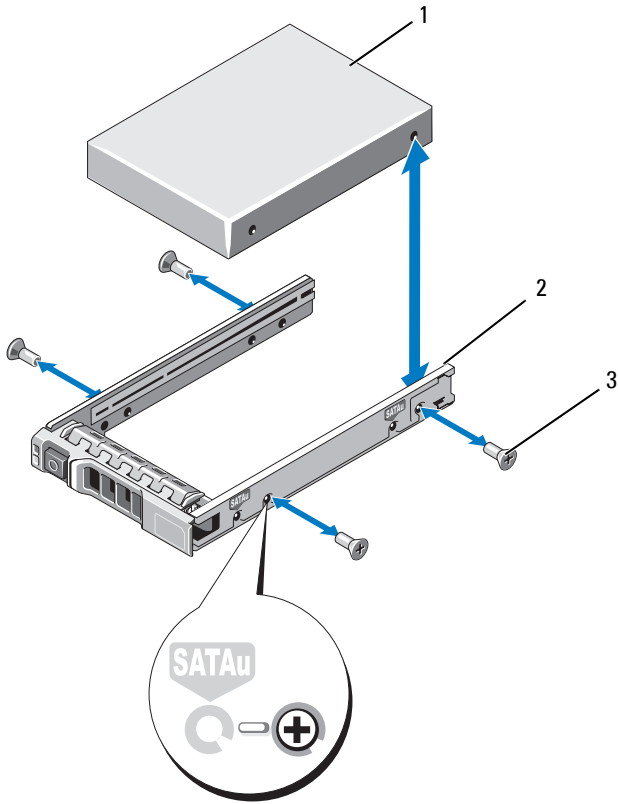
- 1 Insert the hard drive into the hard-drive carrier with the drive's controller board's connector end of the drive at the back of the carrier. See Figure 3-57.
- 2 From the back of the carrier, slide the drive into the carrier until it contacts the stop tab on the front of the carrier.
- 3 Align the screw holes on the hard drive with the holes on the hard-drive carrier. For SATA drives, align the drive mounting holes with the carrier mounting holes marked **SATA**. See Figure 3-57.



**CAUTION: To avoid damaging the drive or the carrier, do not overtighten the screws.**

- 4 Attach the four screws to secure the hard drive to the hard-drive carrier.

**Figure 3-57. Removing and Installing a Hard Drive in a Hard-Drive Carrier**



- 1 hard drive
- 3 screws (4)

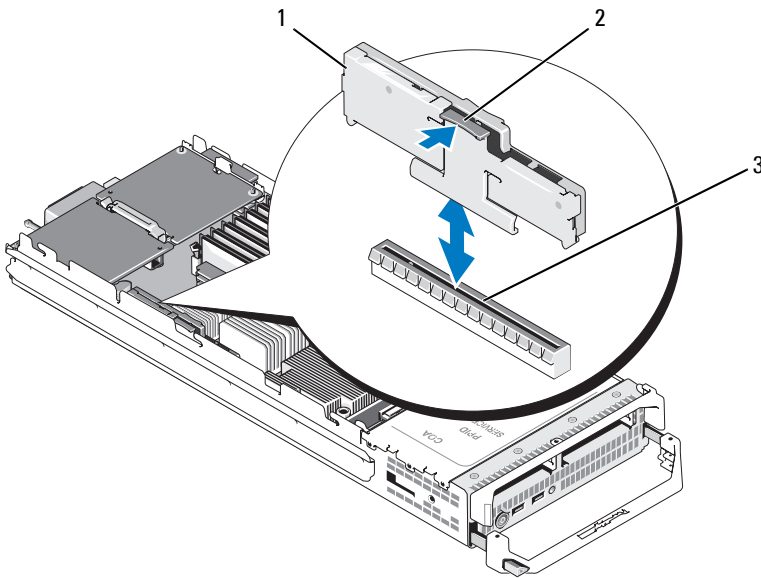
- 2 hard-drive carrier

# Video Controller (PowerEdge M905, M805, M605, and M600 Only)

Follow these steps to remove and replace the video controller:

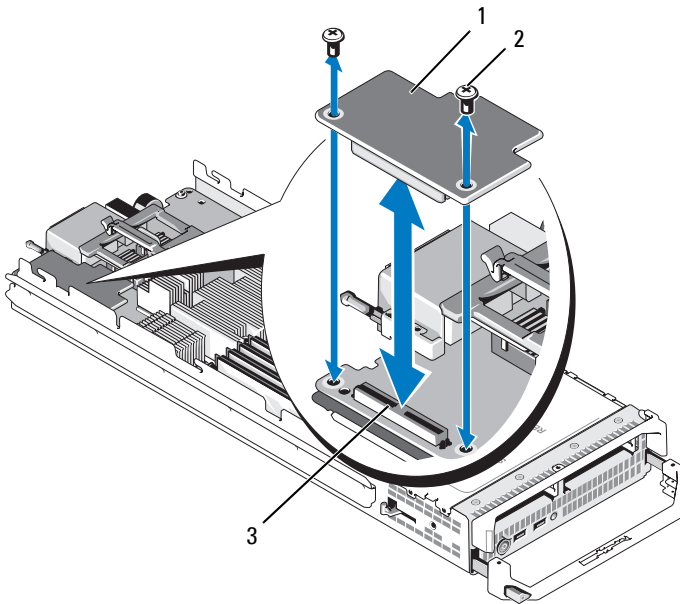
- 1 Remove the blade. See "Removing a Blade" on page 155.
- 2 Open the blade. See "Opening the Blade" on page 159.
- 3 Remove the video controller:
  - If you are removing the video controller from a PowerEdge M905, M805, or M605, remove the two torx screws securing the daughter card, then lift the card from the blade. See Figure 3-59.
  - If you are removing the video controller from a PowerEdge M600, press the latch on the upper edge of the video riser card, then lift the card from the blade. See Figure 3-58.

**Figure 3-58. Removing and Installing a Video Riser Card (PowerEdge M600 Shown)**



- |   |                           |   |       |
|---|---------------------------|---|-------|
| 1 | video riser card          | 2 | latch |
| 3 | connector on system board |   |       |

**Figure 3-59. Removing and Installing a Video Controller Daughter Card (PowerEdge M605 Shown)**





- |   |                           |   |                 |
|---|---------------------------|---|-----------------|
| 1 | video controller board    | 2 | torx screws (2) |
| 3 | connector on system board |   |                 |

**4** To install a new video controller:

- *If you are installing a video controller in a PowerEdge M600, align the edge connector on the riser card with the connector on the system board, and then lower the riser card into place until the connector is fully seated and the latch snaps into place. See Figure 3-58.*
- *If you are installing a video controller in a PowerEdge M605, align the connector on the underside of the controller card with the connector on the system board, and then lower the card into place. Secure the card with the two screws. See Figure 3-59.*

## Hard-Drive Backplane


 **NOTE:** A hard-drive backplane must be installed in each blade to maintain proper airflow, even when the blade is in a diskless configuration.

 **NOTE:** PowerEdge M600, M610, M610x, M710, M710HD, M805, M905, and M910 have one hard-drive backplane and PowerEdge M915 has two hard-drive backplanes. To locate the hard-drive backplane, see "Inside the System" on page 162.

Follow these steps to remove and replace the hard-drive backplane:

1 Remove the blade. See "Removing a Blade" on page 155.

2 Open the blade. See "Opening the Blade" on page 159.

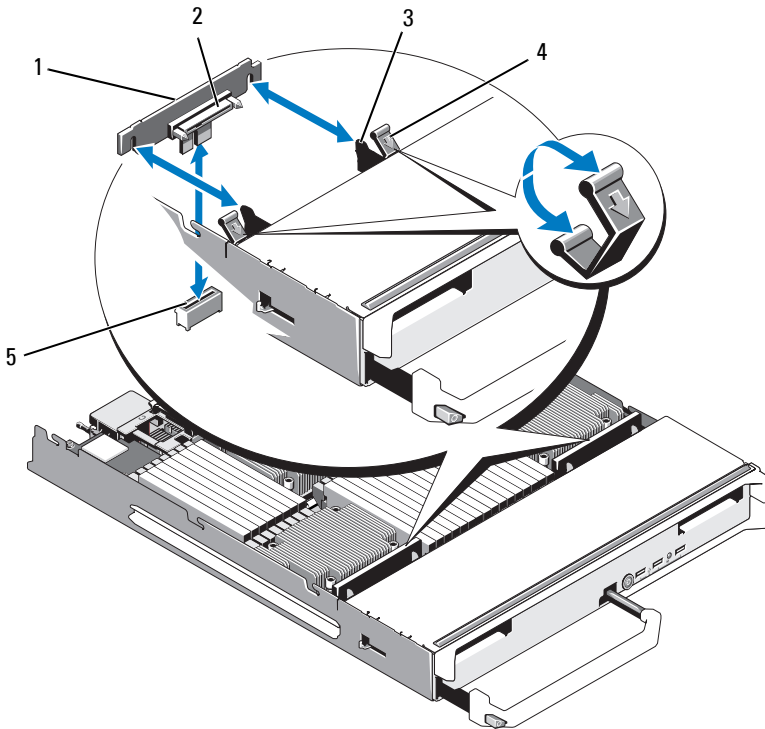
 **NOTE:** If you are removing more than one hard drive, label them so you can replace them in their original locations.

 **NOTE:** You must remove all hard drives from a backplane before removing it.

3 Remove the hard drive(s). See "Removing a Hard Drive" on page 269.

4 Lift the latches at each end of the backplane and lift the backplane from the blade chassis. See Figure 3-60.

**Figure 3-60. Removing and Installing the Hard-Drive Backplane (M915 Shown)**



- |   |                          |   |                           |
|---|--------------------------|---|---------------------------|
| 1 | hard-drive backplane (2) | 2 | hard-drive connectors (2) |
| 3 | retention hooks (4)      | 4 | latches (4)               |
| 5 | backplane connector (2)  |   |                           |

**5** To install the hard-drive backplane:

- a** Hold the backplane with the drive connectors facing towards the hard drive bays.
- b** Position the backplane so that the retention hooks on the end of the drive bay are aligned with the corresponding slots in the backplane.
- c** Press the backplane into place until the connector is fully seated and the latches at each end snap over the upper edge of the board.

- 6 Replace the hard drive(s).  
If you are installing multiple drives, be sure to reinstall them in their original locations.
- 7 Close the blade. See "Closing the Blade" on page 161.
- 8 Install the blade. See "Installing a Blade" on page 158.

## Blade System Board

### Removing the System Board

- 1 Remove the blade. See "Removing a Blade" on page 155.
- 2 Open the blade. See "Opening the Blade" on page 159.
- 3 Install an I/O connector cover on the I/O connector(s) at the back of the board.



**WARNING:** The processor and heat sink can become extremely hot. Be sure the processor has had sufficient time to cool before handling.



**WARNING:** The memory modules are hot to the touch for some time after the system has been powered down. Allow time for the memory modules to cool before handling them. Handle the memory modules by the card edges and avoid touching the components.



**NOTE:** If you are removing more than one hard drive, label them so you can replace them in their original locations.

- 4 Remove the hard drives. See "Removing a Hard Drive" on page 269.
- 5 Remove the hard-drive backplane. See "Hard-Drive Backplane" on page 274.
- 6 If required, remove the integrated network card. See "Network Daughter Card/LOM Riser Card (PowerEdge M915 and M710HD Only)" on page 233.
- 7 If applicable, remove the FlexMem bridge. See "FlexMem Bridge (PowerEdge M910 Only)" on page 261.
- 8 *For a full-height blade*, remove mezzanine cards 1 and 4 (the outermost mezzanine cards).  
*For a half-height blade*, remove both mezzanine cards if present.

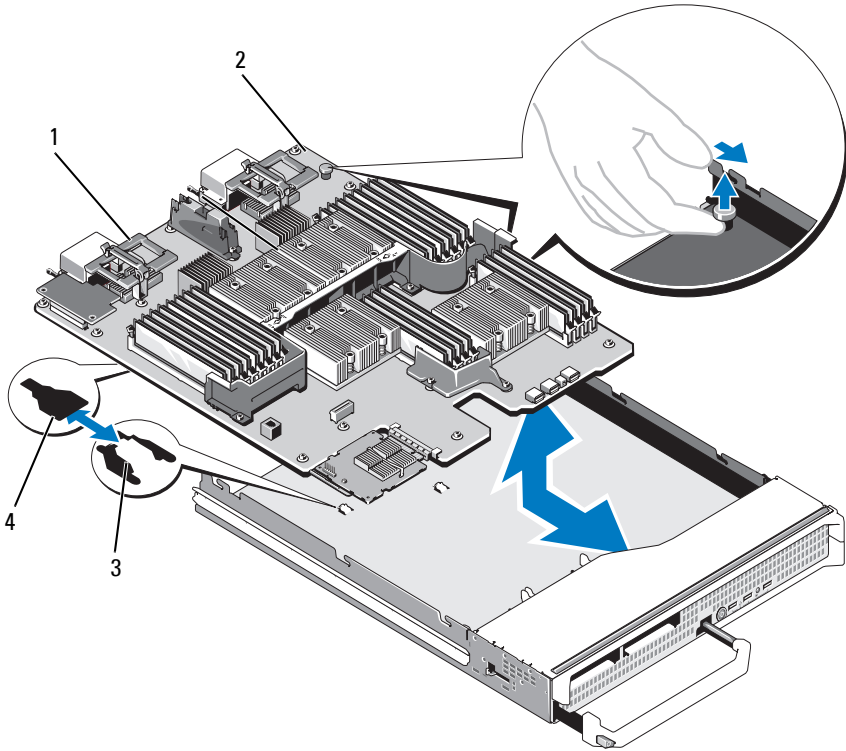




**NOTE:** If you are removing multiple mezzanine cards, label them so that you can replace them in their original locations.

- 9 *To remove a full-height blade system board:*
  - a Use the thumb and index fingers of your right hand to lift the system board retention pin. See Figure 3-61.
  - b Keeping the retention pin raised with your index finger, press the corner of the blade chassis with your thumb to slide the system board out of the open end of the chassis.

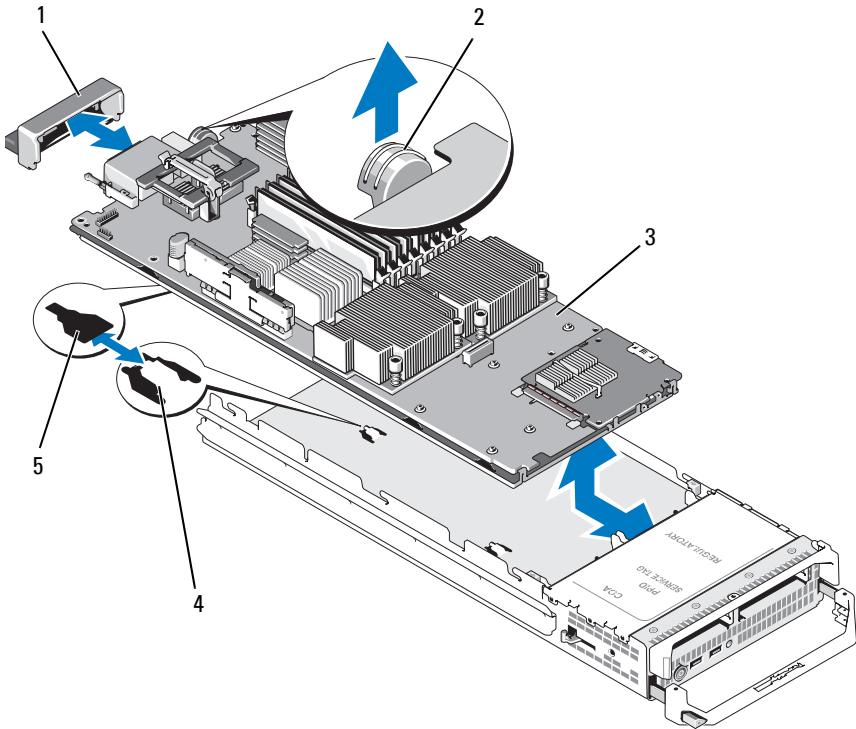
**Figure 3-61. Removing and Installing a System Board (Full-Height Blades – PowerEdge M905 Shown)**



- |   |                        |   |                            |
|---|------------------------|---|----------------------------|
| 1 | system board           | 2 | system board retention pin |
| 3 | tabs on system chassis | 4 | slots in system board tray |

To remove a half-height blade system board, hold the blade chassis with one hand, lift and pull the system board retention latch with the other hand, and then slide the system board out of the open end of the chassis. See Figure 3-62.

**Figure 3-62. Removing and Installing the System Board - Half-Height Blades**



- |   |                            |   |                        |
|---|----------------------------|---|------------------------|
| 1 | I/O connector cover        | 2 | retention latch        |
| 3 | system board               | 4 | tabs on system chassis |
| 5 | slots in system board tray |   |                        |

**NOTE:** If you are removing multiple mezzanine cards, label them so you can replace them in their original locations.

- 10 Ensure that the I/O connector cover is still in place on the I/O connector at the back of the board. See Figure 3-61 or Figure 3-62.

- 11 Remove the video riser card or daughter card. See "Video Controller (PowerEdge M905, M805, M605, and M600 Only)" on page 272.
- 12 Remove the memory modules and memory module blanks. See "Removing Memory Modules" on page 214.
- 13 Remove the processor(s). See "Removing a Processor" on page 244.
- 14 Remove the storage controller board. See "Removing the Storage Controller Board" on page 281.
- 15 Remove the NIC hardware activation key. See "System Board Connectors" on page 338 for the location of the key.

## Installing the System Board

- 1 Transfer the following components to the new system board:
  - NIC hardware activation key. See "System Board Connectors" on page 338 for the location of the key.
  - Internal USB key.
  - Storage controller board. See "Installing the Storage Controller Board" on page 282.
  - SD vFlash card (PowerEdge M910, M710, and M610 only). See "SD vFlash Card (PowerEdge M915, M910, M710, M710HD, M610, and M610x Only)" on page 225.
  - SD card. See "SD Card" on page 223.
  - Memory modules and memory module blanks. See "Installing Memory Modules" on page 213.
  - Processor(s) and heat sink(s), or processor filler blank. See "Installing a Processor" on page 259.
  - HT bridge cards (PowerEdge M905 only). See "HT Bridge Card (PowerEdge M905 Only)" on page 262.
  - FlexMem bridges (PowerEdge M910 only). See "FlexMem Bridge (PowerEdge M910 Only)" on page 261.

- 2 Slide the new system board into the open end of the blade chassis until the retention latch or retention pin engages.



**NOTE:** Ensure that the system board plate is parallel with the chassis.

When the board assembly is installed correctly, the tabs on the system board pan fit into the corresponding openings in the floor of the blade chassis. See Figure 3-61 or Figure 3-62.

- 3 Reinstall the video daughter card or video riser card. See "Video Controller (PowerEdge M905, M805, M605, and M600 Only)" on page 272.
- 4 If applicable, reinstall the integrated network card. See "Network Daughter Card/LOM Riser Card (PowerEdge M915 and M710HD Only)" on page 233.
- 5 Replace the mezzanine card(s) in their original locations. See "Installing a Mezzanine Card" on page 219.
- 6 Reinstall the hard-drive backplane. See "Hard-Drive Backplane" on page 274.
- 7 Replace the hard drive(s).
  - *If there are multiple drives*, be sure to reinstall them in their original locations.
  - *If only one hard-drive is installed*, install it in bay 0.
- 8 Close the blade. See "Closing the Blade" on page 161.
- 9 Remove the plastic I/O connector covers from the back of the blade.
- 10 Install the blade. See "Installing a Blade" on page 158.

## Storage Controller Card

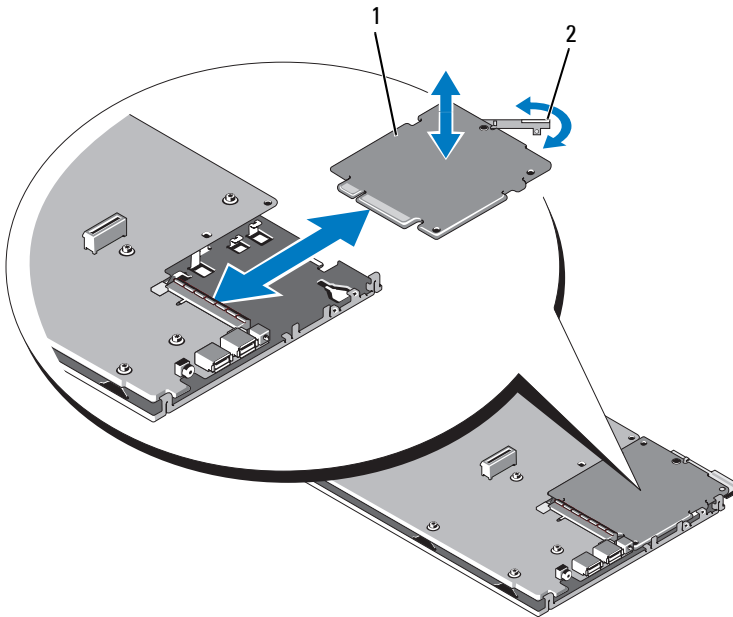
The storage controller board is located underneath the drive bays.

### Removing the Storage Controller Board

- 1 Remove the blade. See "Removing a Blade" on page 155.
- 2 Open the blade. See "Opening the Blade" on page 159.
- 3 Remove the system board and place it on the work surface. See "Removing the System Board" on page 276.
- 4 Open the release lever to disengage the controller board edge connector from the system board connector.

- 5 If you are removing a RAID controller, disconnect the RAID battery from the controller board.
- 6 Lift the controller board straight up from the system board.

**Figure 3-63. Removing and Installing the Storage Controller Card (Half-Height Blade Shown)**



1 storage controller card

2 release lever

### Installing the Storage Controller Board

- 1 To place the storage controller board onto the system board, align the controller board so that the tabs on the metal system board tray fit through the corresponding notches in the edges of the controller board.
- 2 Slide the board toward the connector on the system board until the board's edge connector is fully seated.
- 3 If you are installing a RAID controller, connect the RAID battery to the controller.

- 4 Reinstall the system board. See "Installing the System Board" on page 280.
- 5 Install the blade. See "Installing a Blade" on page 158.

## Midplane Interface Card (PowerEdge M610x)

The midplane interface card is an additional chassis option that provides the capability to use PCIe cards.

### Removing the Midplane Interface Card

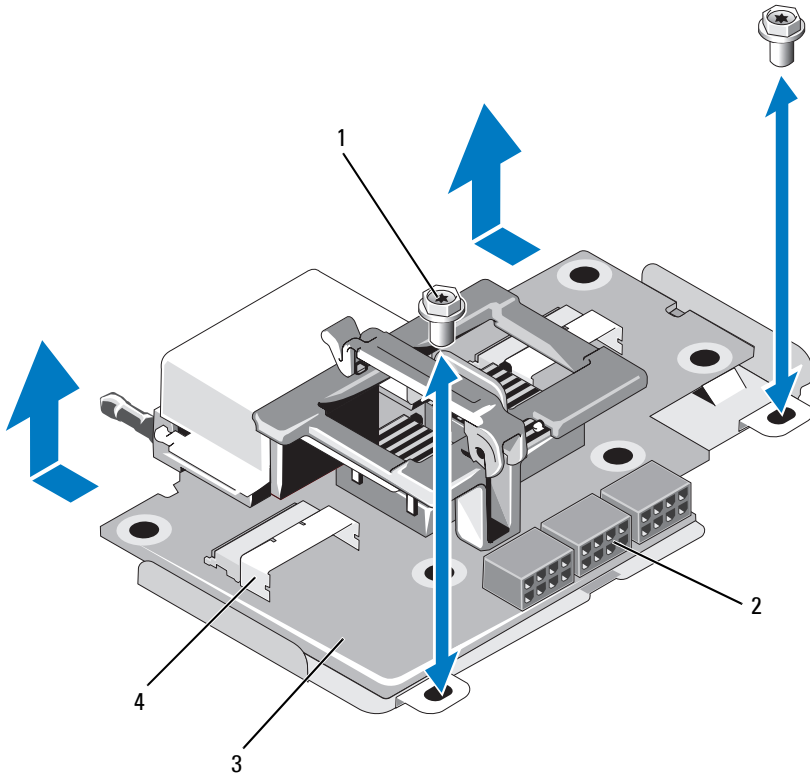
- 1 Remove the blade. See "Removing a Blade" on page 155.
- 2 Open the blade. See "Opening the Blade" on page 159.
- 3 Install an I/O connector cover on the I/O connector(s) at the back of the board.
- 4 Remove both mezzanine cards, if present. See "Removing a Mezzanine Card" on page 222.



**NOTE:** If you are removing multiple mezzanine cards, label them so that you can replace them in their original locations.

- 5 Ensure that the I/O connector cover is still in place on the I/O connector at the back of the board.

**Figure 3-64. Removing and Installing the Midplane Interface Card - PowerEdge M610x**



- |   |                         |   |                            |
|---|-------------------------|---|----------------------------|
| 1 | screws (2)              | 2 | power cable connectors (3) |
| 3 | midplane interface card | 4 | data cable connectors (2)  |

- 6 Disconnect the power and data cables from the connectors on the midplane interface card.  
To disconnect the power and data cables, press the release latch on the connector, push inward slightly, then outward to release the cable connector from the board connector.
- 7 Remove the screws securing the midplane interface card to the chassis.



- 8 Slide the midplane interface card toward the back of the chassis and lift it out of the chassis.

### **Installing the Midplane Interface Card**

- 1 Position the midplane interface card into the blade chassis by sliding it in from the back of the chassis.
- 2 Tighten the screws that secure the midplane interface card to the chassis. See Figure 3-64.




**NOTE:** Ensure that the midplane interface card is parallel with the chassis.

- 3 Connect the power and data cables to the connectors on the midplane interface card.
- 4 Replace the mezzanine card(s) in their original locations. See "Installing a Mezzanine Card" on page 219.
- 5 Close the blade. See "Closing the Blade" on page 161.
- 6 Remove the plastic I/O connector covers from the back of the blade.
- 7 Install the blade. See "Installing a Blade" on page 158.





# Installing Enclosure Components

 **NOTE:** To ensure proper operation and cooling, all bays in the enclosure must be populated at all times with either a module or with a blank.

## Power Supply Modules

The M1000e enclosure supports up to six hot-swappable power supply modules, accessible from the enclosure back panel.

 **NOTE:** The 2360 W and 2700 W power supply modules require 200–240 V input from a PDU. If the power supply modules are plugged into 110 V electrical outlets, the system provides 2200 W AC input power if you select the **Allow 110 VAC Operation** check box in the CMC **Power Configuration** screen.


 **NOTE:** The power supply modules have internal fans that provide thermal cooling to these modules. A power supply module must be replaced if an internal fan failure occurs.


## System Power Guidelines

Your system has one of the following power supply configurations:

- Three 2360 W or three 2700 W power supply modules, which do not provide redundancy if one power supply module fails. The power supplies are installed in bays 1 through 3.
- Six 2360 W or six 2700 W power supply modules, which provide redundancy if up to three power supply modules fail.

The CMC module controls power management for the system. You can program the CMC to configure the power budget, redundancy, and dynamic power of the entire enclosure (chassis, servers, I/O modules, iKVM, CMC, and power supplies). The power management service optimizes power consumption and re-allocates power to different modules based on real-time demand. For more information, see "Power Management" in the *Dell Chassis Management Controller User's Guide*.


 **NOTE:** The wattage of a power supply module is listed on its regulatory label.

 **NOTE:** PDU inlet cords for this system may be too thick to fit in the wire guides installed in the rack vertical rails. If this is the case, remove the wire guides by removing the attachment screw securing each guide. Route the PDU inlet cords along the vertical rails, securing them with tie wraps or Velcro strips.

## Power Supply Blanks

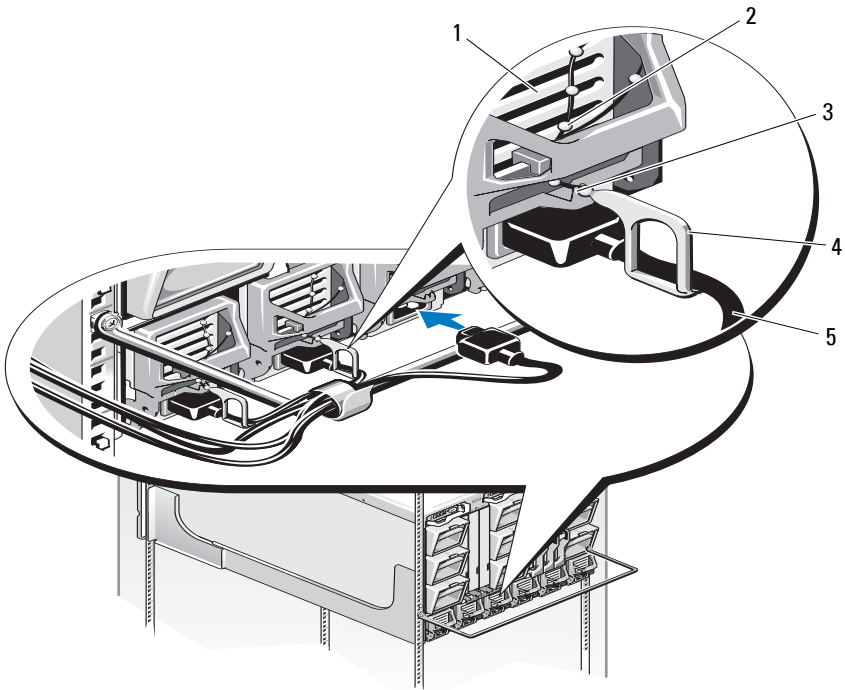
If the M1000e enclosure is operated with only three power supplies, power supply blanks must be installed in the three unoccupied power supply bays (4 through 6) to maintain proper cooling airflow in the enclosure.

## Removing a Power Supply Module

 **NOTE:** The power supply modules are hot swappable. Remove and replace only one power supply module at a time in a system that is turned on.

- 1 Release the power cord retention clip and disconnect the power cord from the power supply module. See Figure 4-1.

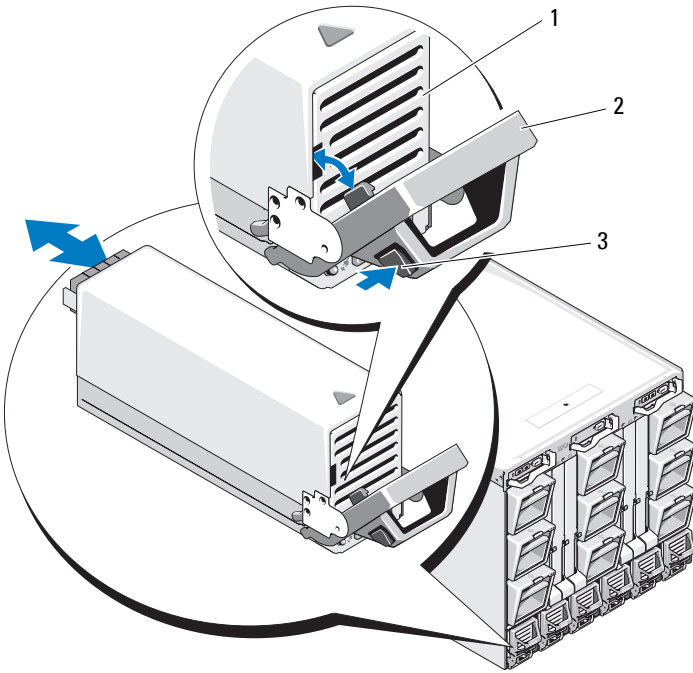
**Figure 4-1. Power Cable Retention Clip**



- |   |                              |   |                       |
|---|------------------------------|---|-----------------------|
| 1 | power supply                 | 2 | retention clip tether |
| 3 | notch in power supply handle | 4 | retention clip        |
| 5 | power cable                  |   |                       |

**2** Press down on the power supply module release button on the handle. See Figure 4-2.

**Figure 4-2. Removing and Installing a Power Supply Module**



- 1 power supply
- 3 release button

2 handle

- 3 Rotate the power supply module handle down to eject the power supply module.
- 4 Slide the power supply module out of the enclosure.

## Installing a Power Supply Module

- 1 Ensure that the power supply module handle is fully open and the power cable is not plugged into the electrical outlet.
- 2 Slide the power supply module into the enclosure. See Figure 4-2.
- 3 Rotate the power supply module handle upward until it latches.
- 4 Plug a power cable into the power supply module.
- 5 Secure the cable to the power supply with the retention clip by fitting the retention clip over the cable, and fitting the retention clip tether into the notch in the power supply handle. See Figure 4-1.

## Fan Modules

The M1000e enclosure contains nine hot-swappable fan modules. All nine fan modules must be installed at all times to ensure proper cooling.

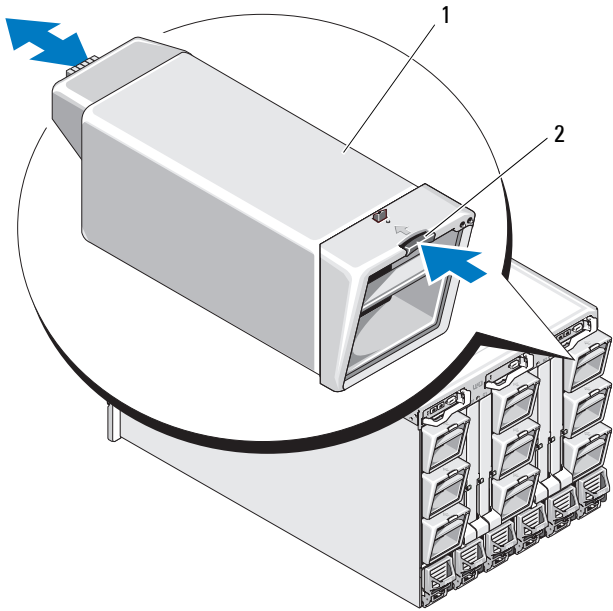
### Removing a Fan Module



**NOTE:** After a fan module is removed from the system, replace it immediately.

- 1 Identify the failed system fan module using the back-panel fan module indicators. See Figure 1-18.
- 2 Remove the fan module:
  - a Press the fan-module release button. See Figure 4-3.
  - b Slide the fan module out of the enclosure.

**Figure 4-3. Removing and Installing a Fan Module**



1 fan module

2 release button

### **Installing a Fan Module**

- 1** Inspect the fan for debris before installing the fan in the enclosure.
- 2** Slide the fan module into the enclosure until it is fully seated and the release button engages. See Figure 4-3.

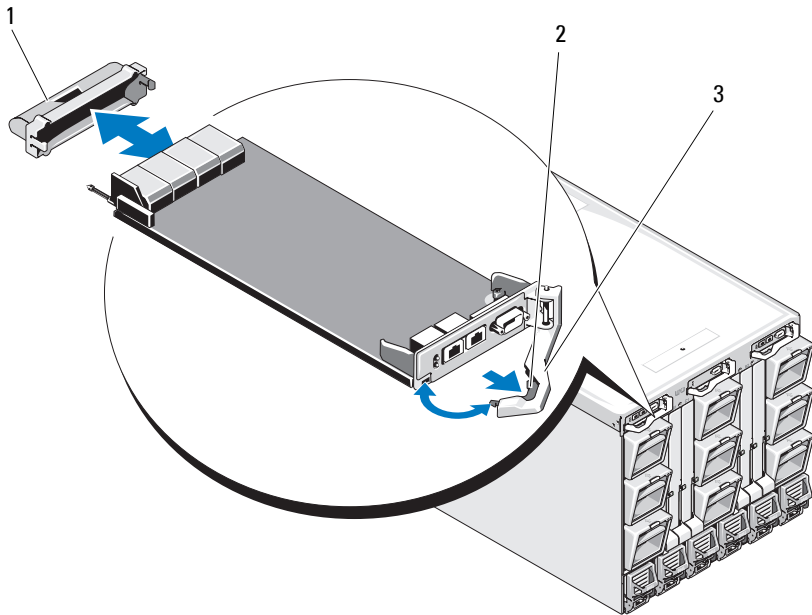


# CMC Module

## Removing a CMC Module

- 1 Disconnect the cables attached to the CMC module.
- 2 Push the release latch on the handle and rotate the handle away from the module front panel.
- 3 Slide the CMC module out of the enclosure.
- 4 Install the I/O connector cover. See Figure 4-4.

**Figure 4-4. Removing and Installing a CMC Module or iKVM Module (CMC Module Shown)**




- 1 I/O connector cover
- 3 release lever


- 2 release latch

## Installing an SD Card in the CMC Module

The SD card slot on the CMC module supports an optional WWN/MAC feature that allows slot-based WWN/MACs for the blades, simplifying blade installation and replacement.

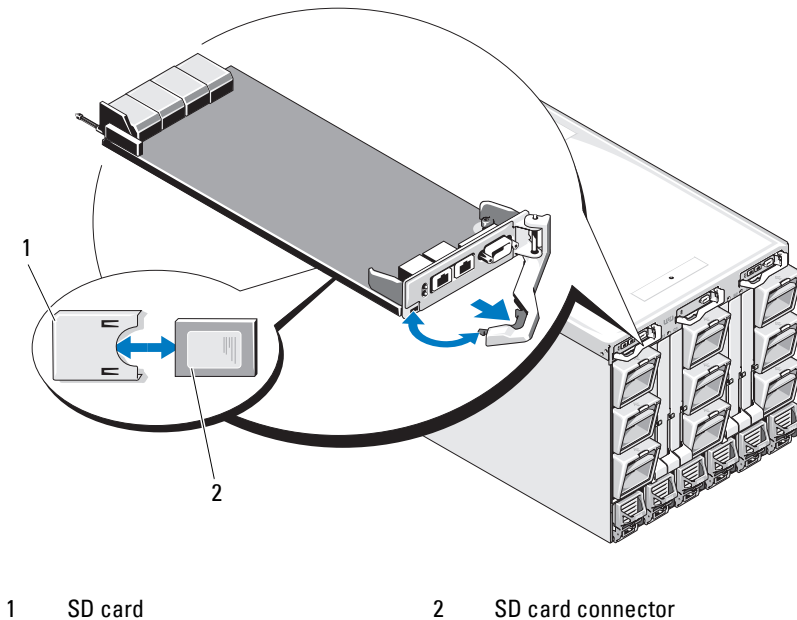
 **NOTE:** For a redundant CMC module system, install the SD card on the passive module. The blue status indicator is off on the passive module.

- 1 Remove the CMC module from the M1000e enclosure. See "Removing a CMC Module" on page 293.

 **NOTE:** Verify the write protection latch is in the "unlock" position.

- 2 Locate the SD card slot on the bottom of the CMC module and insert the contact-pin end of the card into the slot with the label on the card facing upwards. See Figure 4-5.

**Figure 4-5. Installing an SD Card in the CMC Module**



- 3 Reinstall the CMC module and reattach any cables that were disconnected. See "Installing a CMC Module" on page 295.

On a single CMC system, the SD card activates automatically. For redundant CMC module systems, initiate a changeover to make the passive module active using the following steps:

- 1 Navigate to the **Chassis** page.
- 2 Click the **Power Management** tab.
- 3 Click the **Control** sub tab.
- 4 Select the **Reset CMC (warm boot)** button.
- 5 Click **Apply**.

The CMC automatically fails over to the redundant module, and that module now becomes active and displays a solid blue status LED. The SD card activates automatically.

See the *CMC User's Guide* for information on configuration and usage of the FlexAddress feature.

## **Installing a CMC Module**

- 1 Remove the I/O connector cover. See Figure 4-4.
- 2 Ensure that the CMC module handle is fully open.
- 3 Slide the module into the enclosure until the handle contacts the enclosure.
- 4 To fully seat the module, close the handle until the release latch snaps into place.
- 5 Reconnect the cables that were attached to the module.

# iKVM Module

## Removing an iKVM Module

- 1 Disconnect the cables attached to the iKVM module.
- 2 Press in the release latch on the handle and rotate the handle away from the module front panel. See Figure 4-4.
- 3 Slide the module out of the enclosure.

## Installing an iKVM Module

- 1 Ensure that the module handle is fully open. See Figure 4-4.
- 2 Slide the module into the enclosure until the handle contacts the enclosure.
- 3 To fully seat the module, close the handle until the release latch snaps into place.
- 4 If applicable, connect the keyboard, monitor, and mouse to the module.

# I/O Modules

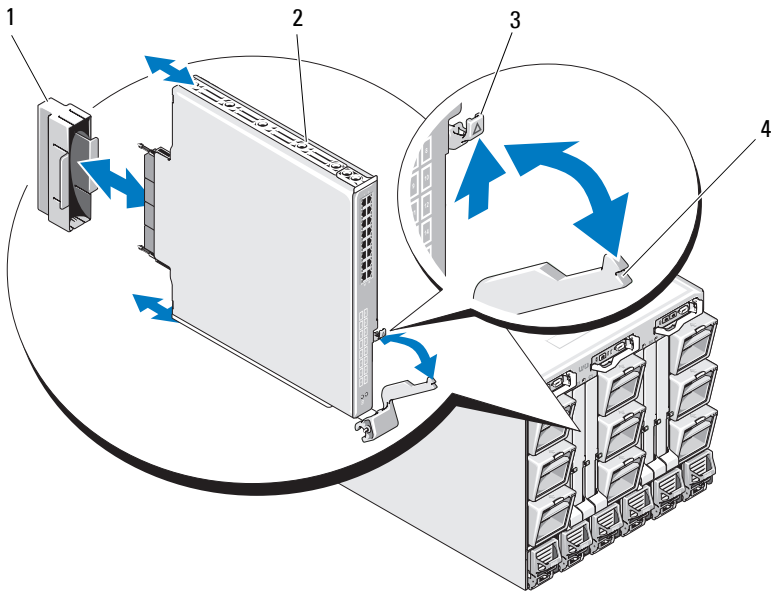


**CAUTION: If you remove an I/O module, you must either replace it with another I/O module or with a filler blank to maintain cooling airflow through the system enclosure.**

## Removing an I/O Module

- 1 If you have not already installed the cable enumerators to make removal and replacement of the I/O modules easier and faster, install them now. See the *Rack Installation Guide* for details.
- 2 Disconnect the cables attached to the I/O module.
- 3 Lift the latch on the end of the module's handle and rotate the handle away from the module. See Figure 4-6.
- 4 Slide the I/O module out of the enclosure.
- 5 Install the I/O connector cover.

**Figure 4-6. Removing and Installing an I/O Module**



- 1 I/O connector cover
- 3 release latch

- 2 I/O module
- 4 handle

## Installing an I/O Module



**NOTE:** The I/O module must be installed in the appropriate I/O bay. See "Guidelines for Installing I/O Modules" on page 52.

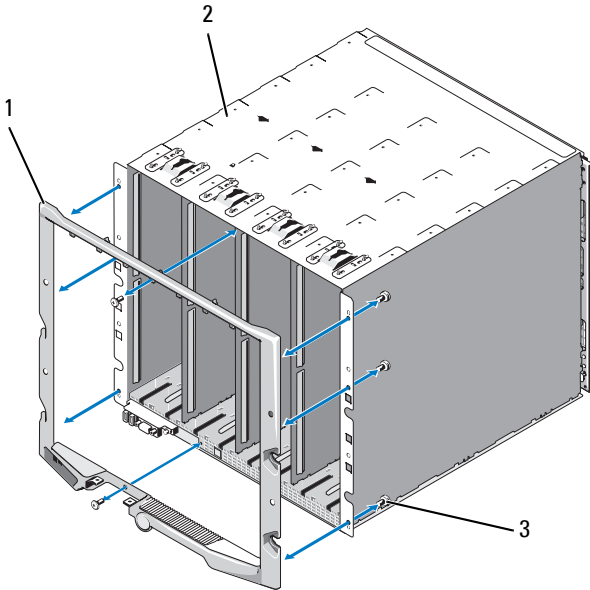
- 1 Unpack the I/O module and prepare it for installation.  
For instructions, see the documentation that accompanied the I/O module.
- 2 Remove the I/O connector cover from the back of the module. See Figure 4-6.
- 3 Install the I/O module in the M1000e enclosure:
  - a Lift the handle release latch and open the I/O module handle.
  - b Slide the module into the enclosure.
  - c Close the handle until it snaps securely into place and the module is fully seated.
- 4 Connect all cables that must be attached to the I/O module.  
See the documentation provided with the I/O module for information about its cable connections. For more information on using the cable enumerators to organize and manage the cables, see the *Rack Installation Guide*.
- 5 A matching fabric mezzanine card must be installed in one or more blades to support the new I/O module. If necessary, install the mezzanine card(s) now. See "I/O Module Mezzanine Cards" on page 217.

## Enclosure Bezel

### Removing the Enclosure Bezel

- 1 Press the system power switch to turn off the system. See "System Control Panel Features" on page 16.
- 2 Rotate the LCD module so that the underside of the module faces upward. See Figure 4-11.
- 3 Remove the cable cover and disconnect the ribbon cable from the LCD module.
- 4 Remove the screws that secure the bezel to the enclosure. See Figure 4-7.

**Figure 4-7. Removing and Installing the Bezel**



1 bezel

2 enclosure


3 screws (8)


### **Installing the Enclosure Bezel**

- 1 Attach the bezel to the enclosure using the screws. See Figure 4-7.
- 2 Connect the ribbon cable to the LCD module, and reinstall the cover plate.


# Enclosure Midplane


Removing the Front Module Cage Assembly and Midplane

 **CAUTION:** Many repairs may only be done by a certified service technician. You should only perform troubleshooting and simple repairs as authorized in your product documentation, or as directed by the online or telephone service and support team. Damage due to servicing that is not authorized by Dell is not covered by your warranty. Read and follow the safety instructions that came with the product.

 **NOTE:** A Torx T15 driver is required for this procedure.

- 1 Press the system power switch to turn off the system. See "System Control Panel Features" on page 16.

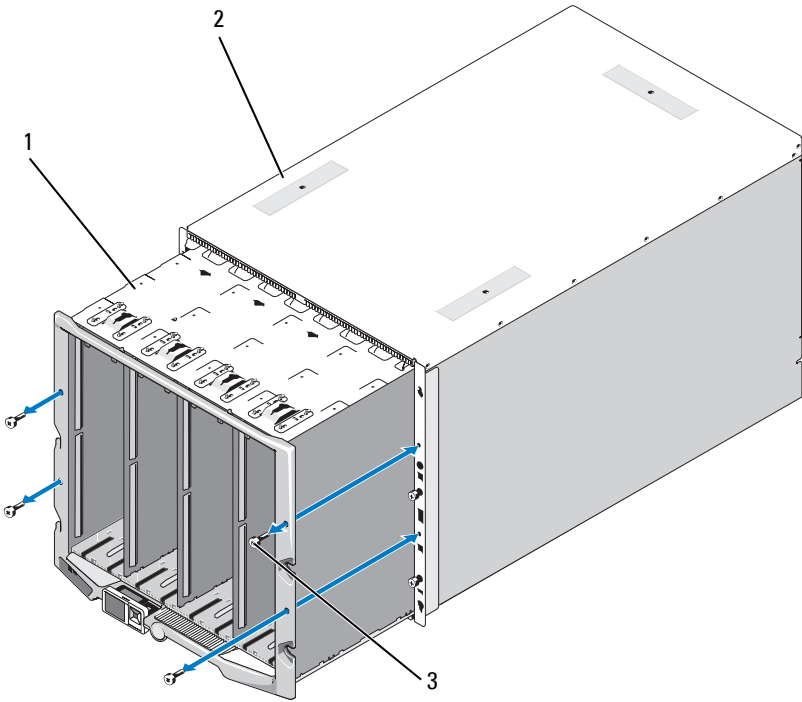
 **NOTE:** To avoid damaging the modules, you must remove all the modules installed in the enclosure before removing the front module cage assembly and midplane.

 **NOTE:** If you remove the chassis from the rack, you must remove all modules before moving the chassis. Do not use the LCD display as a handle when moving the chassis.

- 2 Remove all of the blades. See "Removing a Blade" on page 155.
- 3 Remove the power supply modules. See "Removing a Power Supply Module" on page 288.
- 4 Remove the fan modules. See "Removing a Fan Module" on page 291.
- 5 Remove the CMC module(s). See "Removing a CMC Module" on page 293.
- 6 Remove the iKVM module. See "Removing an iKVM Module" on page 296.
- 7 Remove the I/O modules. See "Removing an I/O Module" on page 296.
- 8 Remove the four screws securing the front module cage assembly to the enclosure. See Figure 4-8.



**Figure 4-8. Removing and Installing the Front Module Cage Assembly**

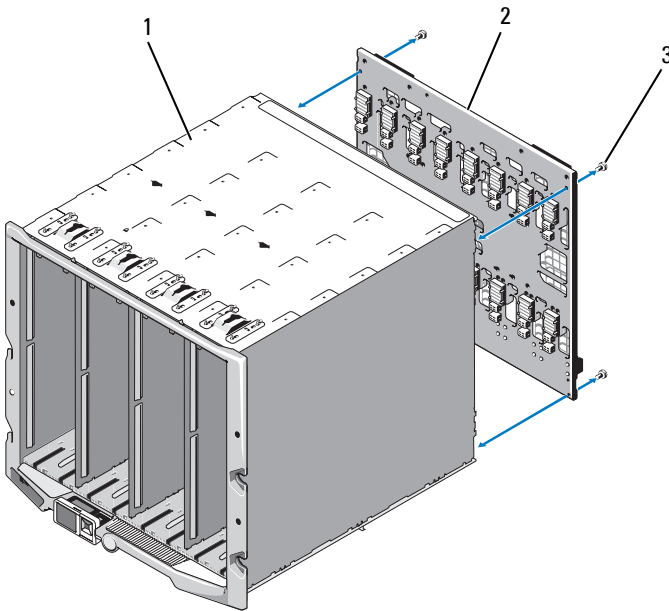


- 1 front module cage assembly
- 2 enclosure
- 3 screws (4)

**NOTE:** The empty cage assembly weighs 21 kg (47 lbs). Obtain assistance when removing the cage assembly from the enclosure.

- 9 Slide the cage out from the enclosure. See Figure 4-8.
- 10 Disconnect the control-panel cable from the midplane by pressing the small latch at each end of the connector.
- 11 Remove the four T-15 Torx screws securing the midplane to the back of the front cage assembly, and remove the midplane. See Figure 4-9.

**Figure 4-9. Removing and Installing the Midplane**



- 1 front module cage assembly
- 2 midplane
- 3 screws (4)

### **Installing the Midplane and Front Module Cage Assembly**

**⚠ CAUTION:** Many repairs may only be done by a certified service technician. You should only perform troubleshooting and simple repairs as authorized in your product documentation, or as directed by the online or telephone service and support team. Damage due to servicing that is not authorized by Dell is not covered by your warranty. Read and follow the safety instructions that came with the product.

- 1 Attach the midplane to the front module cage assembly and secure it with the four Torx screws. See Figure 4-8.
- 2 Connect the control-panel cable to the midplane.
- 3 Carefully slide the front module cage assembly into the enclosure. See Figure 4-9.

- 4 Install the four screws to secure the front module cage assembly.
- 5 Install the I/O modules. See "Installing an I/O Module" on page 298.
- 6 Install the iKVM module. See "Installing an iKVM Module" on page 296.
- 7 Install the CMC module. See "Installing a CMC Module" on page 295.
- 8 Install the fan modules. See "Installing a Fan Module" on page 292.
- 9 Install the power supply modules. See "Installing a Power Supply Module" on page 291.
- 10 Install the blades. See "Installing a Blade" on page 158.

## Enclosure Control Panel Assembly

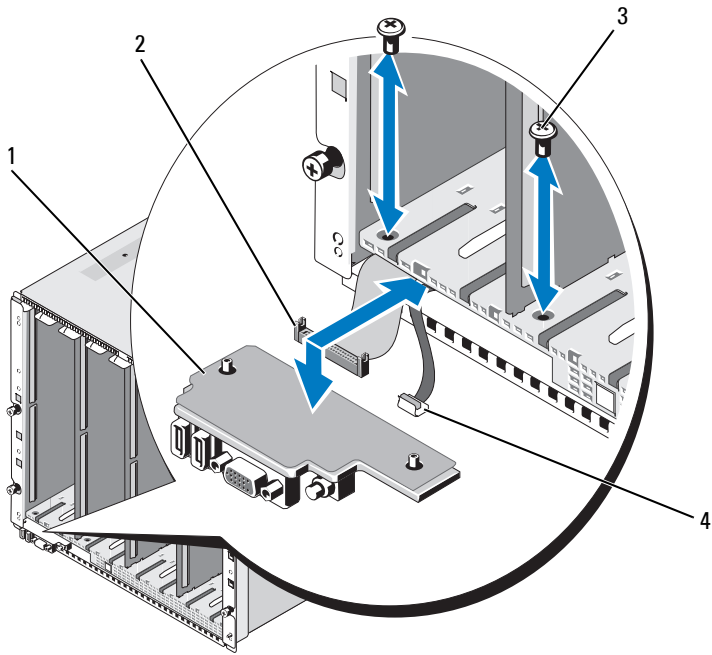
### Removing the Enclosure Control Panel



**CAUTION: Many repairs may only be done by a certified service technician. You should only perform troubleshooting and simple repairs as authorized in your product documentation, or as directed by the online or telephone service and support team. Damage due to servicing that is not authorized by Dell is not covered by your warranty. Read and follow the safety instructions that came with the product.**

- 1 Press the system power switch to turn off the system. See "System Control Panel Features" on page 16.
- 2 Remove the blades. See "Removing a Blade" on page 155.
- 3 Remove the bezel. See "Removing the Enclosure Bezel" on page 298.
- 4 Remove the two screws securing the control panel to the enclosure. See Figure 4-10.


**Figure 4-10. Removing and Installing the Control Panel**



- |   |               |   |                     |
|---|---------------|---|---------------------|
| 1 | control panel | 2 | control-panel cable |
| 3 | screws (2)    | 4 | LCD panel cable     |

- 5 Press the catch at each end of the control-panel cable connector, and remove the control-panel cable from the underside of the control panel.
- 6 Use the pull-tab to disconnect the LCD panel cable from the underside of the control panel.


## Installing the Enclosure Control Panel

 **CAUTION:** Many repairs may only be done by a certified service technician. You should only perform troubleshooting and simple repairs as authorized in your product documentation, or as directed by the online or telephone service and support team. Damage due to servicing that is not authorized by Dell is not covered by your warranty. Read and follow the safety instructions that came with the product.

- 1 Connect the LCD panel cable to the new control panel.
- 2 Connect the control panel cable to the underside of the new control panel.
- 3 Reinstall the control panel using the two screws.
- 4 Reinstall the bezel. See "Installing the Enclosure Bezel" on page 299.
- 5 Install the blades. See "Installing a Blade" on page 158.

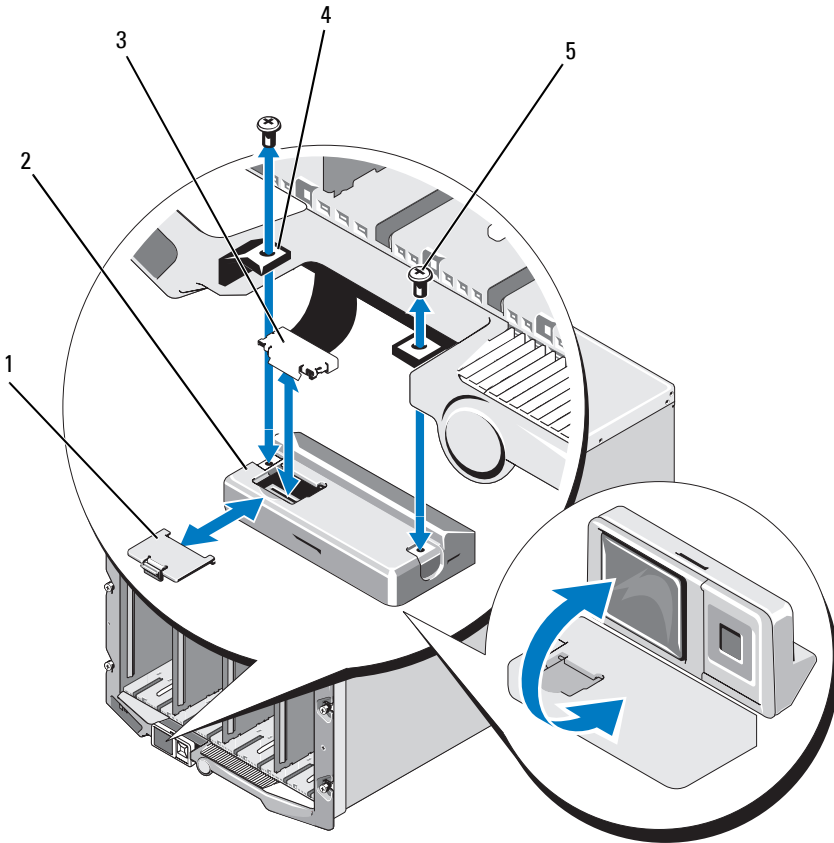
## LCD Module

### Removing the LCD Module

 **CAUTION:** Many repairs may only be done by a certified service technician. You should only perform troubleshooting and simple repairs as authorized in your product documentation, or as directed by the online or telephone service and support team. Damage due to servicing that is not authorized by Dell is not covered by your warranty. Read and follow the safety instructions that came with the product.

- 1 Rotate the LCD module so that the underside of the module faces upward. See Figure 4-11.

**Figure 4-11. Removing and Installing the LCD Module**



- |   |              |   |            |
|---|--------------|---|------------|
| 1 | cable cover  | 2 | LCD module |
| 3 | ribbon cable | 4 | hinges (2) |
| 5 | screws (2)   |   |            |

- 2 Remove the cable cover.
- 3 Disconnect the ribbon cable.
- 4 Remove the two screws securing the LCD module to the hinges.

## Installing the LCD Module



**CAUTION:** Many repairs may only be done by a certified service technician. You should only perform troubleshooting and simple repairs as authorized in your product documentation, or as directed by the online or telephone service and support team. Damage due to servicing that is not authorized by Dell is not covered by your warranty. Read and follow the safety instructions that came with the product.

- 1 Attach the new LCD module to the hinges using the two screws. See Figure 4-11.
- 2 Connect the ribbon cable to the module, and reinstall the cover plate.





# Troubleshooting Your System

## Safety First—For You and Your System

**△ CAUTION:** Many repairs may only be done by a certified service technician. You should only perform troubleshooting and simple repairs as authorized in your product documentation, or as directed by the online or telephone service and support team. Damage due to servicing that is not authorized by Dell is not covered by your warranty. Read and follow the safety instructions that came with the product.

## Start-Up Routine

Look and listen during the system's start-up routine for the indications described in Table 5-1.

**Table 5-1. Start-Up Routine Indicators**

<b>Look/listen for:</b>	<b>Action</b>
An error message displayed on the monitor	See "System Messages" on page 115.
Alert messages from the systems management software	See the systems management software documentation.
The monitor's power indicator	See "Troubleshooting Video" on page 310.
The keyboard indicators	See "Troubleshooting the Keyboard" on page 311.
The USB diskette drive activity indicator	See "Troubleshooting USB Devices" on page 312.
The USB optical drive activity indicator	See "Troubleshooting USB Devices" on page 312.
The hard-drive activity indicator	See "Troubleshooting Hard Drives" on page 320.

## Checking the Equipment

This section provides troubleshooting procedures for external devices attached to the system, such as the monitor, keyboard, or mouse. Before you perform any of the procedures, see "Troubleshooting External Connections" on page 310.

## Troubleshooting External Connections

Loose or improperly connected cables are the most likely source of problems for the system, monitor, and other peripherals (such as a keyboard, mouse, or other external device). Ensure that all external cables are securely attached to the external connectors on your system. See Figure 1-13 for the front-panel connectors on your system and Figure 1-15 for the back-panel connectors.

### Troubleshooting Video

- 1** Check the connection to the iKVM module.  
Try swapping cables if another monitor cable is available.
- 2** Verify that the iKVM firmware revision is current.
- 3** Check the monitor connection to either the front-panel connector on the blade or the back-panel iKVM module.
- 4** Ensure that the port is not disabled by the CMC or by redirection to another port.
- 5** If two or more blades are installed in the enclosure, select a different blade.  
If the monitor is connected to the back-panel iKVM module and works with another blade, the first blade may need to be reseated. See "Removing and Installing a Blade" on page 155. If reseating the blade does not help, the blade may be faulty. See "Getting Help" on page 361.
- 6** Swap the monitor with a known-working monitor.  
If the monitor does not work when connected to the blade front-panel connector, the blade may be faulty. See "Getting Help" on page 361.  
If the monitor does not work when connected to the iKVM module, the iKVM module may be faulty. See "Getting Help" on page 361.

## Troubleshooting the Keyboard

- 1 Ensure that the blade(s) is turned on.
- 2 Verify that the iKVM firmware revision is current.
- 3 Check the keyboard connection to either the front-panel connector on the blade or to the back-panel iKVM module.
- 4 If the keyboard is connected to an external KVM using a SIP, check that the SIP is compatible with the KVM.
- 5 If two or more blades are installed in the enclosure, select a different blade.  
If the keyboard is connected to the back-panel iKVM module and works with another blade, the first blade may need to be reseated. See "Removing and Installing a Blade" on page 155. If reseating the blade does not help, the blade may be faulty. See "Getting Help" on page 361.
- 6 Swap the keyboard with a known-working keyboard and repeat step 3 and step 5. If the keyboard does not work with any blade, see "Getting Help" on page 361.

## Troubleshooting the Mouse

- 1 Ensure that the blade(s) is turned on.
- 2 Verify that the iKVM firmware revision is current.
- 3 Check the mouse connection to the either the front-panel connector on the blade or to the back-panel iKVM module.
- 4 If the keyboard is connected to an external KVM using a SIP, check that the SIP is compatible with the KVM.
- 5 If two or more blades are installed in the enclosure, select a different blade.  
If the mouse is connected to the back-panel iKVM module and works with another blade, the first blade may need to be reseated. See "Removing and Installing a Blade" on page 155. If reseating the blade does not help, the blade may be faulty. See "Getting Help" on page 361.
- 6 Swap the mouse with a known-working mouse and repeat step 3 and step 5. If the mouse does not work with any blade, see "Getting Help" on page 361.

## Troubleshooting USB Devices



**NOTE:** USB devices can be connected only to the blade front panel. Total length of a USB cable should not exceed 3 m (9.8 ft).

- 1 Ensure that the blade(s) is turned on.
- 2 Check the USB device connection to the blade.
- 3 Swap the USB device with a known-working USB device.
- 4 Connect the USB devices to the blade using a powered USB hub.
- 5 If another blade is installed, connect the USB device to that blade. If the USB device works with a different blade, the first blade may be faulty. See "Getting Help" on page 361.

## Responding to a Systems Management Alert Message

The CMC management applications monitor critical system voltages and temperatures, and the cooling fans in the system. For information about the CMC alert messages, see the *Configuration Guide*.

## Troubleshooting a Wet Enclosure



**CAUTION:** Many repairs may only be done by a certified service technician. You should only perform troubleshooting and simple repairs as authorized in your product documentation, or as directed by the online or telephone service and support team. Damage due to servicing that is not authorized by Dell is not covered by your warranty. Read and follow the safety instructions that came with the product.

- 1 Turn off the system.
- 2 Disconnect the power supplies from the PDU.



**CAUTION:** Wait until all of the indicators on the power supplies turn off before proceeding.

- 3 Remove all of the blades. See "Removing a Blade" on page 155.
- 4 Remove the power supply modules. See "Removing a Power Supply Module" on page 288.
- 5 Remove the fan modules. See "Removing a Fan Module" on page 291.

- 6** Remove the CMC module(s). See "Removing a CMC Module" on page 293.
- 7** Remove the iKVM module. See "Removing an iKVM Module" on page 296.
- 8** Remove the I/O modules. See "Removing an I/O Module" on page 296.
- 9** Let the system dry thoroughly for at least 24 hours.
- 10** Install the I/O modules. See "Installing an I/O Module" on page 298.
- 11** Install the iKVM module. See "Installing an iKVM Module" on page 296.
- 12** Install the CMC module. See "Installing a CMC Module" on page 295.
- 13** Install the fan modules. See "Installing a Fan Module" on page 292.
- 14** Install the power supply modules. See "Installing a Power Supply Module" on page 291.
- 15** Install the blades. See "Installing a Blade" on page 158.
- 16** Reconnect the power supply modules to their PDU and start up the system.  
If the system does not start up properly, see "Getting Help" on page 361.
- 17** Run the Server Administrator diagnostics to confirm that the system is working properly. See "Running System Diagnostics" on page 325.  
If the tests fail, see "Getting Help" on page 361.

## Troubleshooting a Damaged Enclosure

- 1** Ensure that the following components are properly installed and connected:
  - CMC module
  - iKVM module
  - I/O modules
  - Power supply modules
  - Fan modules
  - Blades
- 2** Ensure that all cables are properly connected.

- 3 Ensure that all components are properly installed and free from damage.
- 4 Run the online diagnostics. See "Running System Diagnostics" on page 325.

If the tests fail, see "Getting Help" on page 361.

## Troubleshooting Enclosure Components

The following procedures describe how to troubleshoot the following components:

- Power supply modules
- Fan modules
- CMC module
- Network switch module

### Troubleshooting Power Supply Modules




**NOTE:** The power-supply modules are hot swappable. Remove and replace only one power-supply module at a time in a system that is turned on. Leave a failed power-supply module installed in the enclosure until you are ready to replace it. Operating the system with a power-supply module removed for extended periods of time can cause the system to overheat.




**NOTE:** The 2700 W and 2360 W power supply modules require a 200–240 V power source to operate. If the power supply modules are plugged into 110 V electrical outlets, the system provides 2200 W AC input power if you select the **Allow 110 VAC Operation** check box in the CMC Power Configuration screen.

- 1 Locate the faulty power supply module and check the indicators. See Figure 1-17. The power supply's AC indicator is green if AC power is available. The power supply's fault indicator is amber if the power supply is faulty. If no indicators are lit, ensure that 208V AC power is available from the PDU and that the power cable is properly connected to the power supply module.
- 2 Install a new power supply. See "Installing a Power Supply Module" on page 291.

 **NOTE:** After installing a new power supply, allow several seconds for the system to recognize the power supply and determine whether it is working properly. The power supply DC power indicator turns green if the power supply is functioning properly. See Figure 1-17.

- 3 If none of the power supplies show a fault LED and the blades do not power on, check the LCD display or CMC for status messages.
- 4 If the problem is not resolved, see "Getting Help" on page 361.

## Troubleshooting Fan Modules


 **NOTE:** The fan modules are hot swappable. Remove and replace only one fan module at a time in a system that is turned on. Operating the system without all six fan modules for extended periods of time can cause the system to overheat.

- 1 Locate the faulty fan.

Each fan module has indicators that identify a faulty fan. See Figure 1-18.

- 2 Remove the fan module. See "Removing a Fan Module" on page 291.
- 3 Examine the blades for debris. If debris is present, carefully remove it.
- 4 Reseat the faulty fan. See "Installing a Fan Module" on page 292.
- 5 If none of the fans show a fault LED and the blades do not power on, check the LCD display or CMC for status messages.
- 6 If the problem is not resolved, install a new fan.
- 7 If the new fan does not operate, see "Getting Help" on page 361.

## Troubleshooting the CMC Module

 **NOTE:** To eliminate the possibility of a hardware problem with the module or its attaching devices, first ensure that the module is properly initialized and configured. See the *Configuration Guide* and the documentation that came with the module before performing the following procedure.

- 1 Verify that the latest firmware is installed on the CMC module.  
See [support.dell.com](http://support.dell.com) for the latest firmware and refer to the release notes for firmware compatibility and update information.
- 2 Verify that the CMC(s) have valid IP addresses for the subnet. Verify using the ICMP ping command.

 **NOTE:** In an enclosure with two CMCs, both share the same IP address.

- 3 Reseat the CMC module and see if the CMC module fault indicator turns off. See "CMC Module" on page 293 and Figure 1-22 for more information about the module's indicators.
- 4 If another CMC module is available, swap the two modules.
- 5 If the fault indicator is off, but the serial device connected to the serial port is not properly operating, go to step 6. If the fault indicator is off, but the network management device connected to the network interface connector port is not properly operating, go to step 9.



**NOTE:** In an enclosure with two CMCs, serial connections are only supported on the Primary CMC. This is designated by the single blue LED. See Figure 1-22.

- 6 Reseat the serial cable to the serial connector on the CMC module and to the serial device communicating with it.
- 7 Connect a known-working null-modem serial cable between the CMC module and the serial device.
- 8 Connect a known-working serial device to the CMC module.  
If the serial device and CMC module still do not communicate with each other, see "Getting Help" on page 361.
- 9 Reseat the network cable to the network connector on the CMC module and to the network device.
- 10 Connect a known-working network cable between the CMC module and the network device.



**NOTE:** If the CMC is connected to another CMC in an adjacent enclosure and there is no failover, check the network cable connected to port Gb2. If there is no external management connection to the CMC, check the cable connected to port Gb1. See Figure 1-22.

- 11 Connect a known-working network device to the CMC module.  
If the network device and CMC module still do not communicate with each other, see "Getting Help" on page 361.



## Troubleshooting the iKVM Module

### ***Problem:***

When using iDRAC video\console redirection you cannot see video through the iKVM when you switch to a blade running Linux.

### ***Likely Cause and Solution:***

A monitor or KVM appliance with a lower resolution has recently been added.

### ***Example:***

A blade running X Windows under Linux is inserted and powered on. A user connects to the blade in OS GUI mode using the iDRAC and a video resolution is detected and hard-set for that session. A monitor or KVM appliance is attached to the front or back iKVM interface on the M1000e enclosure. The monitor or the KVM appliance is configured with a resolution LOWER than the currently configured resolution in the X-Window session on the Linux blade.

When you select the Linux blade using the front or back port on the iKVM, the iDRAC circuit adopts the lower resolution of the external connected devices. The video on the lower resolution monitor or the KVM appliance is not displayed until X Windows is restarted (iDRAC video should still be viewable.)

### ***Solution:***

- 1** From the iDRAC session, exit and re-enter GUI mode. The lower resolution is communicated and utilized.
- 2** Set all monitors or KVM appliances connected to the M1000e enclosure to the same resolution or higher as configured on the Linux blades in GUI mode.
- 3** From the lower resolution monitor (no video displayed) press <CTRL><ALT><F3> to change to the non-GUI login screen.
- 4** Restart X Windows to detect and utilize the lower resolution.

## Troubleshooting a Network Switch Module



**NOTE:** To eliminate the possibility of a hardware problem with the module or its attaching devices, first ensure that the module is properly initialized and configured. See the *Configuration Guide* and the documentation that came with the module before performing the following procedure.

- 1 Check that you have installed the module in an I/O slot that matches its fabric type. See "Supported I/O Module Configurations" on page 56.
- 2 Check that the passthrough module or switch ports are cabled correctly.  
A given mezzanine card in a full-height blade connects to two I/O ports on the two associated I/O modules. See "I/O Module Port Assignments - Full-Height Blades (not applicable for PowerEdge M610x)" on page 61.
- 3 Using the "17th blade" feature of the CMC, use the Connect Switch-X command to verify that the switch is fully booted, and verify the switch's firmware revision and IP address.
- 4 Verify that the switch module has a valid IP address for the subnet. Verify using the ICMP **ping** command.
- 5 Check the network connector indicators on the network switch module.
  - If the link indicator displays an error condition, check all cable connections. See "I/O Connectivity" on page 52 for the link indicator error conditions for your particular network switch module.
  - Try another connector on the external switch or hub.
  - If the activity indicator does not light, replace the network switch module. See "I/O Modules" on page 296.
- 6 Using the switch management interface, verify the switch port properties. If the switch is configured correctly, back up the switch configuration and replace the switch. See the switch module documentation for details.
- 7 If the blade requires a mezzanine card for a particular network switch module, ensure that the appropriate mezzanine card is installed. If so, reseal the mezzanine card. See "I/O Module Mezzanine Cards" on page 217.  
If the network link indicator on the blade is green, then the blade has a valid link to the appropriate network switch module.
- 8 Ensure that the appropriate operating system drivers are installed and that the protocol settings are configured to ensure proper communication.

# Troubleshooting Blade Components

The following procedures describe how to troubleshoot the following components. See Figure 3-5 for the location of the components inside the blade.

- Memory
- Hard drives
- Expansion cards
- Processors
- Blade system board
- Battery

## Troubleshooting Blade Memory



**NOTE:** Before performing the following procedure, ensure that you have installed the memory modules according to the memory installation guidelines for the blade. See "System Memory" on page 171.

- 1 Restart the blade.
  - a Press the power button once to turn off the blade.
  - b Press the power button again to apply power to the blade.If no error messages appear, go to step 8.
- 2 Enter the System Setup program and check the system memory setting. See "Using the System Setup Program and UEFI Boot Manager" on page 137.  
If the amount of memory installed matches the system memory setting, go to step 8.
- 3 Remove the blade. See "Removing a Blade" on page 155.
- 4 Open the blade. See "Opening the Blade" on page 159.



**CAUTION:** The memory modules are hot to the touch for some time after the blade has been powered down. Allow time for the memory modules to cool before handling them. Handle the memory modules by the card edges and avoid touching the components.

- 5 Reseat the memory modules in their sockets. See "Installing Memory Modules" on page 213.

- 6 Close the blade. See "Closing the Blade" on page 161.
- 7 Install the blade. See "Installing a Blade" on page 158.
- 8 Run the system memory test in the system diagnostics. See "Running System Diagnostics" on page 325.  
If the test fails, see "Getting Help" on page 361.

## Troubleshooting Hard Drives



**CAUTION:** This troubleshooting procedure can destroy data stored on the hard drive. Before you proceed, back up all the files on the hard drive, if possible. Refer to the RAID controller documentation for rebuilding and servicing a RAID array.

- 1 Run the appropriate controllers test and the hard drive tests in system diagnostics. See "Running System Diagnostics" on page 325.  
If the tests fail, go to step 3.
- 2 Take the hard drive offline and wait until the hard-drive indicator codes on the drive carrier signal that the drive may be removed safely, then remove and reseat the drive carrier in the blade. See "Hard Drives" on page 267.
- 3 Restart the blade, enter the System Setup program, and confirm that the drive controller is enabled. See "Integrated Devices Screen" on page 144.
- 4 Ensure that any required device drivers are installed and are configured correctly.



**NOTE:** Installing a hard drive into another bay may break the mirror if the mirror state is optimal.

- 5 Remove the hard drive and install it in the other drive bay. See "Hard Drives" on page 267.
- 6 If the problem is resolved, reinstall the hard drive in the original bay.  
If the hard drive functions properly in the original bay, the drive carrier could have intermittent problems. Replace the drive carrier.
- 7 If the hard drive is the boot drive, ensure that the drive is configured and connected properly. See "Configuring the Boot Drive" on page 269.
- 8 Partition and logically format the hard drive.
- 9 If possible, restore the files to the drive.  
If the problem persists, see "Getting Help" on page 361.

## Troubleshooting Expansion Cards



**CAUTION:** Many repairs may only be done by a certified service technician. You should only perform troubleshooting and simple repairs as authorized in your product documentation, or as directed by the online or telephone service and support team. Damage due to servicing that is not authorized by Dell is not covered by your warranty. Read and follow the safety instructions that came with the product.



**NOTE:** When troubleshooting an expansion card, see the documentation for your operating system and the expansion card.

- 1 Run the appropriate online diagnostic test. See "Running the System Diagnostics" on page 326.
- 2 Remove the blade. See "Removing a Blade" on page 155.
- 3 Open the blade. See "Opening the Blade" on page 159.
- 4 Verify that the installed expansion cards are compliant with the expansion card installation guidelines. See "Expansion Card Installation Guidelines" on page 235.
- 5 Ensure that the expansion card is firmly seated in its connector. See "Installing an Expansion Card" on page 236.
- 6 Close the blade. See "Closing the Blade" on page 161.
- 7 Install the blade. See "Installing a Blade" on page 158.
- 8 If the problem is not resolved, remove the blade. See "Removing a Blade" on page 155.
- 9 Open the blade. See "Opening the Blade" on page 159.
- 10 Remove all expansion cards installed in the blade. See "Removing an Expansion Card" on page 238.
- 11 Close the blade. See "Closing the Blade" on page 161.
- 12 Install the blade and turn it on. See "Installing a Blade" on page 158.
- 13 Run the appropriate online diagnostic test.  
If the test fails, see "Getting Help" on page 361.

- 14 For each expansion card you removed in step 10, perform the following steps:
  - a Open the blade. See "Opening the Blade" on page 159.
  - b Reinstall one of the expansion cards.
  - c Close the blade. See "Closing the Blade" on page 161.
  - d Install the blade and turn it on. See "Installing a Blade" on page 158.
  - e Run the appropriate diagnostic test.
- 15 For M610x only, if the problem persists after reseating the expansion cards, reseal the power and data cables and run the appropriate diagnostic test.
- 16 If the tests fail, see "Getting Help" on page 361.

## Troubleshooting Processors

- 1 Remove the blade. See "Removing a Blade" on page 155.
- 2 Open the blade. See "Opening the Blade" on page 159.
- 3 Ensure that the processor(s) and heat sink(s) are properly installed. See "Processors" on page 243.
- 4 *If your system only has one processor installed*, ensure that it is installed in the primary processor socket. See Figure 7-13 or Figure 7-12.
- 5 *For a PowerEdge M905 system*, check that hypertransport (HT) bridge cards are installed in sockets CPU3 and CPU4, and that both cards are fully seated in the processor sockets. See "HT Bridge Card (PowerEdge M905 Only)" on page 262.
- 6 Close the blade. See "Closing the Blade" on page 161.
- 7 Install the blade. See "Installing a Blade" on page 158.
- 8 Run **Quick Tests** in the system diagnostics. See "Running System Diagnostics" on page 325.  
If the tests fail or the problem persists, see "Getting Help" on page 361.

## Troubleshooting the Blade Board

- 1** Remove the blade. See "Removing a Blade" on page 155.
- 2** Open the blade. See "Opening the Blade" on page 159.
- 3** Clear the blade NVRAM.  
See "Blade System Board Jumper Settings" on page 331 for the location of the NVRAM\_CLR jumper.
- 4** If there is a still a problem with the blade, remove and reinstall the blade.  
See "Installing a Blade" on page 158.
- 5** Turn on the blade.
- 6** Run the system board test in the system diagnostics. See "Running System Diagnostics" on page 325.  
If the tests fail, see "Getting Help" on page 361.

## Troubleshooting the NVRAM Backup Battery

Each blade contains a battery that maintains the blade configuration, date, and time information in NVRAM when you turn off the blade. You may need to replace the battery if an incorrect time or date is displayed during the boot routine.

You can operate the blade without a battery; however, the blade configuration information maintained by the battery in NVRAM is erased each time you remove power from the blade. Therefore, you must re-enter the system configuration information and reset the options each time the blade boots until you replace the battery.

- 1 Re-enter the time and date through the System Setup program. See "Using the System Setup Program and UEFI Boot Manager" on page 137.
- 2 Remove the blade for at least one hour. See "Removing a Blade" on page 155.
- 3 Install the blade. See "Installing a Blade" on page 158.
- 4 Enter the System Setup program.

If the date and time are not correct in the System Setup program, replace the battery. See "Blade System Board NVRAM Backup Battery" on page 265.

If the problem is not resolved by replacing the battery, see "Getting Help" on page 361.



**NOTE:** If the blade is turned off for long periods of time (for weeks or months), the NVRAM may lose its system configuration information. This situation is caused by a defective battery.



**NOTE:** Some software may cause the blade's time to speed up or slow down. If the blade seems to operate normally except for the time kept in the System Setup program, the problem may be caused by software rather than by a defective battery.



# Running System Diagnostics

If you experience a problem with your blade, run the diagnostics before calling for technical assistance. The purpose of the diagnostics is to test your blade's hardware without requiring additional equipment or risking data loss. If you are unable to fix the problem yourself, service and support personnel can use diagnostics test results to help you solve the problem.

## Dell PowerEdge Diagnostics

To assess a system problem, first use the online Dell PowerEdge Diagnostics. Dell PowerEdge Diagnostics is a suite of diagnostic programs, or test modules, that include diagnostic tests on chassis and storage components such as hard drives, physical memory, communications ports, NICs, CMOS, and more. If you are unable to identify the problem using the PowerEdge Diagnostics, then use the system diagnostics described in the remainder of this section. The system diagnostics program is run from the iDRAC6 Express System Services menu or from the hard-drive utility partition.

The files required to run PowerEdge Diagnostics for systems running supported Microsoft Windows and Linux operating systems are available at [support.dell.com](http://support.dell.com) and on the CDs that came with your system. For information about using diagnostics, see the *Dell Online PowerEdge Diagnostics User's Guide*.

## System Diagnostics Features

The system diagnostics provides a series of menus and options for particular device groups or devices on a blade. The system diagnostics menus and options allow you to:

- Run tests individually or collectively
- Control the sequence of tests
- Repeat tests
- Display, print, or save test results

- Temporarily suspend testing if an error is detected or terminate testing when a user-defined error limit is reached
- View help messages that briefly describe each test and its parameters
- View status messages that inform you if tests are completed successfully
- View error messages that inform you of problems encountered during testing

## When to Use the System Diagnostics

If a major component or device in the blade does not operate properly, component failure may be indicated. As long as the processor and the blade's input/output devices (monitor, keyboard, and diskette drive) are functioning, you can use the system diagnostics to help identify the problem.

## Running the System Diagnostics

The system diagnostics can be run from either Unified Server Configurator GUI or a USB flash drive.



**NOTE:** Use the system diagnostics to test only your blade. Use only the program that came with your blade (or an updated version of that program).

## Running the Embedded System Diagnostics

The embedded system diagnostics program is run from the Unified Server Configurator screen.



**CAUTION:** Use the embedded system diagnostics to test only your system. Using this program with other systems may cause invalid results or error messages.

- 1 In the left pane of Unified Server Configurator screen, click **Hardware Diagnostics**.
- 2 In the right pane, click **Run Hardware Diagnostics**. When the diagnostics utility launches, follow the on-screen instructions.
- 3 To exit the utility, reboot the system and press <F10> to re-enter USC or USC-LCE.

The results of the diagnostics tests are displayed on the screen when the tests are complete. To resolve the problems found in the test results, search the resolutions from [support.dell.com](http://support.dell.com).

## From a USB Flash Drive

- 1 Format the USB flash drive to emulate a hard drive.  
See the documentation that came with your USB flash drive for instructions.
- 2 Configure the USB flash drive to be a bootable device.  
See the documentation that came with your USB flash drive for instructions. Dell also provides a USB memory key boot utility for download at [support.dell.com](http://support.dell.com).
- 3 Install DKMS DOS on the USB flash drive.
- 4 Create a directory for the system diagnostics on the USB flash drive.
- 5 Copy the system diagnostics files into the directory.
- 6 Ensure that you have the USB flash drive connected to the blade.
- 7 Enter the System Setup program and ensure that the **USB Flash Drive Emulation Type** option is set to **Auto** and set the USB flash drive as the first device in the **Hard-Disk Drive Sequence** option.  
See "Using the System Setup Program and UEFI Boot Manager" on page 137 for instructions.



**NOTE:** If you power up or reboot the blade without the USB flash drive connected to the blade, you must reset the options in the System Setup program again.

- 8 Ensure that you have the USB flash drive connected to the blade.
- 9 Reboot the blade.  
If the blade fails to boot, see "Contacting Dell" on page 361.

When you start the system diagnostics, a message is displayed stating that the diagnostics are initializing. Next, the **Diagnostics** menu appears. The menu allows you to run all or specific diagnostics tests or to exit the system diagnostics.



**NOTE:** Before you read the rest of this section, start the system diagnostics so that you can see the utility on your screen.

# System Diagnostics Testing Options

To select an option from the **Diagnostics** menu, highlight the option and press <Enter>, or press the key that corresponds to the highlighted letter in the option.

Table 6-1 provides a brief explanation of testing options.

**Table 6-1. System Diagnostics Testing Options**

Testing Option	Function
Quick Tests	Performs a quick check of the blade. Select <b>Test All Devices</b> and then select <b>Quick Tests</b> . This option runs device tests that do not require user interaction. Use this option to quickly identify the source of your problem.
Test One Device	Tests a particular device.
Extended Tests	Performs a more thorough check of the blade. Select <b>Test All Devices</b> and then select <b>Extended Tests</b> .
Advanced Testing	Checks a particular area of the blade.
Information and Results	Displays test results.
Program Options	Sets various test parameters.
Device Configuration	Displays an overview of the devices in the blade.
Exit to MS-DOS	Exits the diagnostics and returns to the <b>System Utilities</b> menu.

## Using the Advanced Testing Options

When you select **Advanced Testing** from the **Diagnostics** menu, the main screen of the diagnostics appears and displays the following information:

- Two lines at the top of the screen identify the diagnostics utility, the version number, and the system's service tag number.
- The left side of the screen under **Device Groups** lists the diagnostic device groups in the order that they are tested if you select **All** under the **Run Tests** submenu. Press the up- or down-arrow keys to highlight a particular device group. Press the left- or right-arrow keys to select the options on the menu. As you move from one menu option to another, a brief explanation of the highlighted option appears at the bottom of the screen.
- The right side of the screen under **Devices for Highlighted Group** lists the specific devices within a particular test group.
- The menu area consists of two lines at the bottom of the screen. The first line lists the menu options that you can select; press the left- or right-arrow key to highlight an option. The second line provides information about the highlighted option.

For more information about a device group or device, highlight the **Help** option and press <Enter>. Press <Esc> to return to the previous screen.


## Error Messages

When you run a system diagnostics test, you may receive an error message during testing. Record the message on a copy of the **Diagnostics Checklist**. For a copy of the **Diagnostics Checklist** and instructions for obtaining technical assistance, see "Contacting Dell" on page 361.




# System Board Information

## Blade System Board Jumper Settings





 **CAUTION:** Many repairs may only be done by a certified service technician. You should only perform troubleshooting and simple repairs as authorized in your product documentation, or as directed by the online or telephone service and support team. Damage due to servicing that is not authorized by Dell is not covered by your warranty. Read and follow the safety instructions that came with the product.

### PowerEdge M915 Jumper Settings

Figure 7-1 shows the location of the configuration jumpers on the blade system board. Table 7-1 lists the jumper settings.


 **NOTE:** Figure 7-1 is oriented with the front end of the blade system board facing to the right.

**Table 7-1. PowerEdge M915 Jumper Settings**





PWRD_EN		(default)	The password feature is enabled.
			The password feature is disabled.
NVRAM_CLR		(default)	The configuration settings are retained at system boot.
			The configuration settings are cleared at the next system boot. (If the configuration settings become corrupted to the point where the system does not boot, install the jumper and boot the system. Remove the jumper before restoring the configuration information.)

## PowerEdge M910 Jumper Settings

Figure 7-3 shows the location of the configuration jumpers on the blade system board. Table 7-2 lists the jumper settings.


 **NOTE:** Figure 7-3 is oriented with the front end of the blade system board facing to the right.

**Table 7-2. PowerEdge M910 Jumper Settings**



PSWD_EN		(default)	The password feature is enabled.
			The password feature is disabled.
NVRAM_CLR		(default)	The configuration settings are retained at system boot.
			The configuration settings are cleared at the next system boot. (If the configuration settings become corrupted to the point where the system does not boot, install the jumper and boot the system. Remove the jumper before restoring the configuration information.)

## PowerEdge M905 Jumper Settings

Figure 7-3 shows the location of the configuration jumpers on the blade system board. Table 7-3 lists the jumper settings.

 **NOTE:** Figure 7-3 is oriented with the front end of the blade system board facing to the right.



**Table 7-3. PowerEdge M905 Jumper Settings**

PSWD_EN		(default)	The password feature is enabled.
			The password feature is disabled.



**Table 7-3. PowerEdge M905 Jumper Settings (continued)**


---

NVRAM_CLR		(default)	The configuration settings are retained at system boot.
			The configuration settings are cleared at the next system boot. (If the configuration settings become corrupted to the point where the system does not boot, install the jumper and boot the system. Remove the jumper before restoring the configuration information.)

---





### PowerEdge M805 Jumper Settings

Figure 7-4 shows the location of the configuration jumpers on the blade system board. Table 7-4 lists the jumper settings.

 **NOTE:** Figure 7-4 is oriented with the front end of the blade system board facing to the right.

**Table 7-4. PowerEdge M805 Jumper Settings**


---

PSWD_EN		(default)	The password feature is enabled.
			The password feature is disabled.
NVRAM_CLR		(default)	The configuration settings are retained at system boot.
			The configuration settings are cleared at the next system boot. (If the configuration settings become corrupted to the point where the system does not boot, install the jumper and boot the system. Remove the jumper before restoring the configuration information.)





---

## PowerEdge M710 Jumper Settings

Figure 7-5 shows the location of the configuration jumpers on the blade system board. Table 7-5 lists the jumper settings.

 **NOTE:** Figure 7-5 is oriented with the front end of the blade system board facing to the right.

**Table 7-5. PowerEdge M710 Jumper Settings**

PWRD_EN	 (default)	The password feature is enabled. (Pins 2-3)
		The password feature is disabled. (Pins 1-2)
NVRAM_CLR	 (default)	The configuration settings are retained at system boot. (Pins 4-5)
		The configuration settings are cleared at the next system boot. (Pins 5-6)  (If the configuration settings become corrupted to the point where the system does not boot, install the jumper and boot the system. Remove the jumper before restoring the configuration information.)

## PowerEdge M710HD Jumper Settings





Figure 7-6 shows the location of the configuration jumpers on the blade system board. Table 7-6 lists the jumper settings.



**NOTE:** Figure 7-6 is oriented with the front end of the blade system board facing to the right.

**Table 7-6. PowerEdge M710HD Jumper Settings**


---

PSWD_EN		(default)	The password feature is enabled.
			The password feature is disabled.
<hr/>			
NVRAM_CLR		(default)	The configuration settings are retained at system boot.
			The configuration settings are cleared at the next system boot. (If the configuration settings become corrupted to the point where the system does not boot, install the jumper and boot the system. Remove the jumper before restoring the configuration information.)





---

## PowerEdge M610/M610x Jumper Settings

Figure 7-7 shows the location of the configuration jumpers on the blade system board. Table 7-7 lists the jumper settings.

 **NOTE:** Figure 7-7 is oriented with the front end of the blade system board facing to the right.

**Table 7-7. PowerEdge M610/M610x Jumper Settings**

PWRD_EN		(default)	The password feature is enabled. (Pins 1-2)
			The password feature is disabled. (Pins 2-3)
NVRAM_CLR		(default)	The configuration settings are retained at system boot. (Pins 2-3)
			The configuration settings are cleared at the next system boot. (Pins 1-2) (If the configuration settings become corrupted to the point where the system does not boot, install the jumper and boot the system. Remove the jumper before restoring the configuration information.)





## PowerEdge M600 Jumper Settings

Figure 7-13 shows the location of the configuration jumpers on the blade system board. Table 7-8 lists the jumper settings.



**NOTE:** Figure 7-13 is oriented with the front end of the blade system board facing to the right.

**Table 7-8. PowerEdge M600 Jumper Settings**

PWRD_EN		(default)	The password feature is enabled. (Pins 1-2)
			The password feature is disabled. (Pins 2-3)
NVRAM_CLR		(default)	The configuration settings are retained at system boot (Pins 2-3)
			The configuration settings are cleared at the next system boot. (Pins 1-2) (If the configuration settings become corrupted to the point where the system does not boot, install the jumper and boot the system. Remove the jumper before restoring the configuration information.)

# System Board Connectors

## PowerEdge M915 System Board

Figure 7-1. PowerEdge M915 System Board Connectors

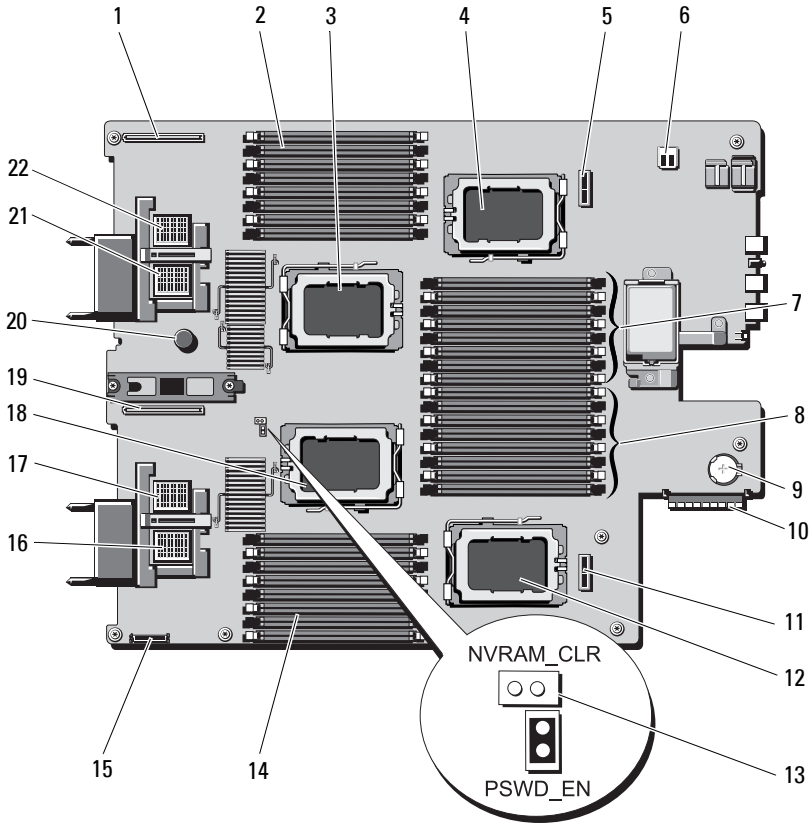


Table 7-9. PowerEdge M915 System Board Connectors

Connector	Description
1 LOM RISER B	Network Daughter Card/LOM Riser card connector
2 B1 – B8	Memory modules B1 – B8 (for processor 2)

**Table 7-9. PowerEdge M915 System Board Connectors (continued)**

Connector	Description
3 CPU2	Processor 2 socket
4 CPU4	Processor 4 socket
5 BACKPLANE 2	Hard-drive backplane connector
6 -	USB connector
7 D1 – D8	Memory modules D1 – D8 (for processor 4)
8 C1 – C8	Memory modules C1 – C8 (for processor 3)
9 -	Connector for the 3.0 V coin battery
10 STORAGE CONTROLLER	Storage controller card connector
11 BACKPLANE 1	Hard-drive backplane connector
12 CPU3	Processor 3 socket
13 PSWD_EN, NVRAM_CLR	System configuration jumpers <b>NOTE:</b> Access requires removal of system board. See "Removing the System Board" on page 276.
14 A1 – A8	Memory modules A1 – A8 (for processor 1)
15 MGMT RISER CONNECTOR	SD vFlash card connector
16 MEZZ1_FAB_C	Mezzanine card connector for Fabric C
17 MEZZ2_FAB_B	Mezzanine card connector for Fabric B
18 CPU1	Processor 1 socket
19 LOM RISER A	Network Daughter Card/LOM Riser card connector
20 -	System board retention pin
21 MEZZ3_FAB_C	Mezzanine card connector for Fabric C
22 MEZZ4_FAB_B	Mezzanine card connector for Fabric B

# PowerEdge M910 System Board

Figure 7-2. PowerEdge M910 System Board Connectors

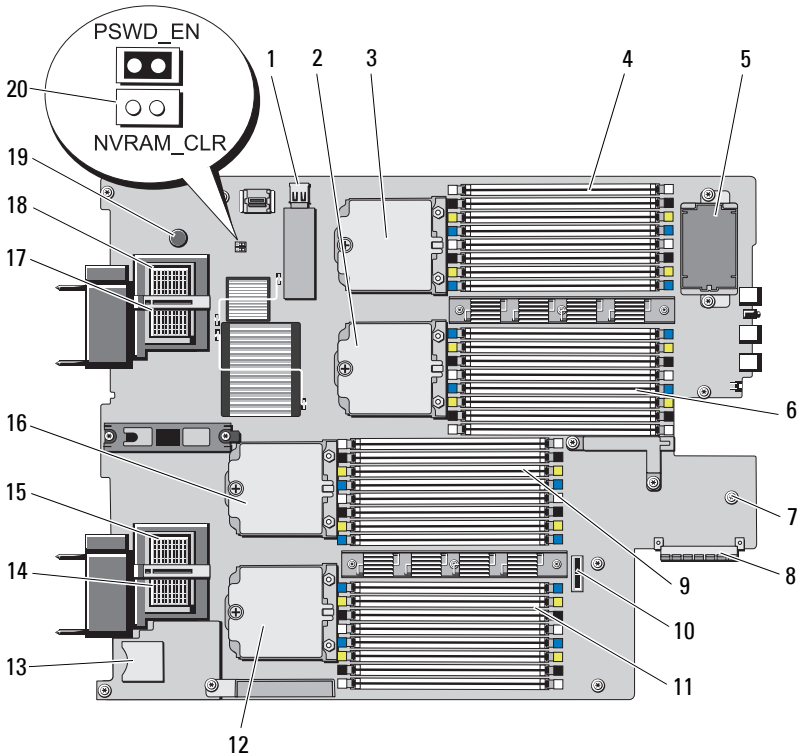


Table 7-10. PowerEdge M910 System Board Connectors

Connector	Description
1 J_INT_USB	USB connector
2 CPU2	Processor 2 socket
3 CPU4	Processor 4 socket
4 B1 – B8	Memory modules B1 – B8
5 -	Optional RAID battery



**Table 7-10. PowerEdge M910 System Board Connectors (continued)**

Connector	Description
6 D1 – D4	Memory modules D1 – D4
7 -	Connector for the 3.0 V coin battery <b>NOTE:</b> Access requires removal of system board. See "Removing the System Board" on page 276.
8 J_STORAGE	Storage controller card connector
9 C1 – C8	Memory modules C1 – C8
10 -	Hard-drive backplane connector
11 A1 – A8	Memory modules A1 – A8
12 CPU3	Processor 3 socket
13 J_RIPS_SD2	SD vFlash Card slot
14 MEZZ1_FAB_C	Mezzanine card connector for Fabric C
15 MEZZ2_FAB_B	Mezzanine card connector for Fabric B
16 CPU1	Processor 1 socket
17 MEZZ3_FAB_C	Mezzanine card connector for Fabric C
18 MEZZ4_FAB_B	Mezzanine card connector for Fabric B
19 -	System board retention pin
20 PSWD_EN, NVRAM_CLR	System configuration jumpers <b>NOTE:</b> Access requires removal of system board. See "Removing the System Board" on page 276.

# PowerEdge M905 System Board

Figure 7-3. PowerEdge M905 System Board Connectors

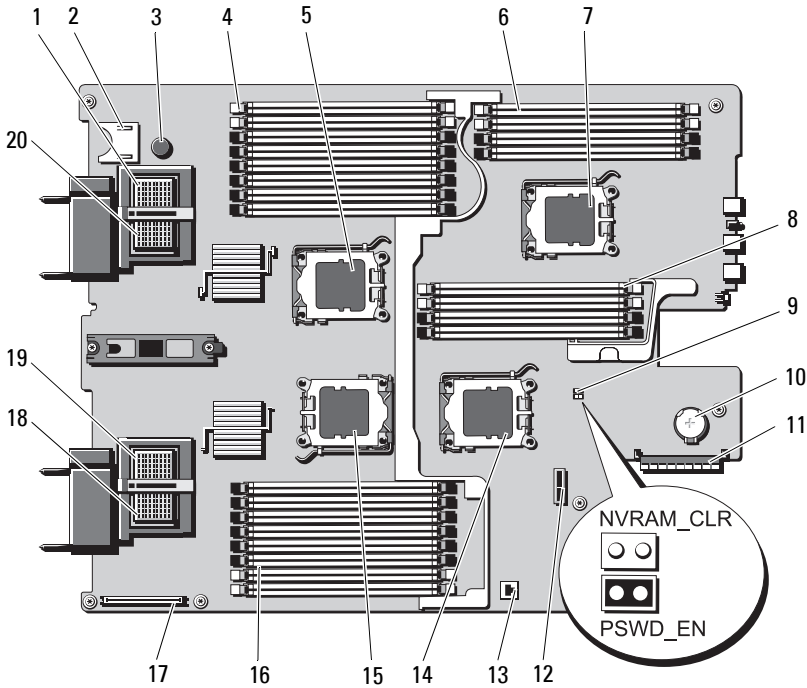


Table 7-11. PowerEdge M905 System Board Connectors

Connector	Description
1 MEZZ4_FAB_B	Mezzanine card connector 4 Fabric B
2 -	SD card connector
3 -	System board retention pin
4 B1 - B8	Memory modules B1 - B8
5 CPU2	Processor 2 socket
6 D1 - D4	Memory modules D1 - D4
7 CPU4	Processor 4 socket

**Table 7-11. PowerEdge M905 System Board Connectors (continued)**

Connector	Description
8 C1 – C4	Memory modules C1 – C4
9 PSWD_EN, NVRAM_CLR	System configuration jumpers <b>NOTE:</b> Access requires removal of system board. See "Removing the System Board" on page 276.
10 -	Connector for the 3.0 V coin battery <b>NOTE:</b> Access requires removal of system board. See "Removing the System Board" on page 276.
11 J_STORAGE	Storage controller card connector
12 -	Hard-drive backplane connector
13 -	Hardware key socket for integrated NIC TOE/iSCSI feature
14 CPU3	Processor 3 socket
15 CPU1	Processor 1 socket
16 A1 – A8	Memory modules A1 – A8
17 -	Video controller card connector
18 MEZZ1_FAB_C	Mezzanine card connector 1 Fabric C
19 MEZZ2_FAB_B	Mezzanine card connector 2 Fabric B
20 MEZZ3_FAB_C	Mezzanine card connector 3 Fabric C

# PowerEdge M805 System Board

Figure 7-4. PowerEdge M805 System Board Connectors

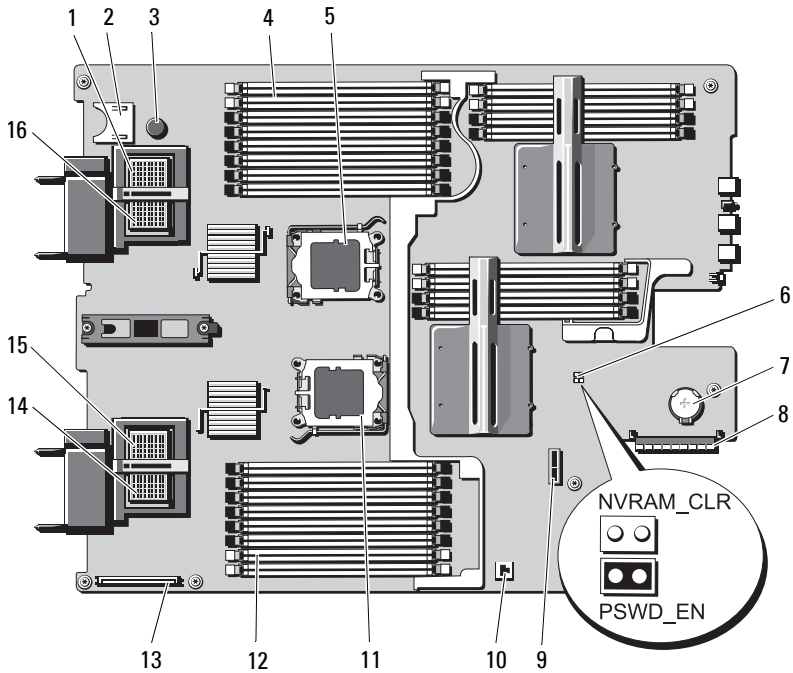


Table 7-12. PowerEdge M805 System Board Connectors

Connector	Description
1 MEZZA4_FAB_B	Mezzanine card connector 4 Fabric B
2 -	SD card connector
3 -	System board retention pin
4 B1 – B8	Memory modules B1 – B8
5 CPU2	Processor 2 socket

**Table 7-12. PowerEdge M805 System Board Connectors (continued)**

Connector	Description
6 PWRD_EN, NVRAM_CLR	System configuration jumpers <b>NOTE:</b> Access requires removal of system board. See "Removing the System Board" on page 276.
7 -	Connector for the 3.0 V coin battery <b>NOTE:</b> Access requires removal of system board. See "Removing the System Board" on page 276.
8 J_STORAGE	Storage controller card connector
9 -	Hard-drive backplane connector
10 -	Hardware key socket for integrated NIC TOE/iSCSI feature
11 CPU1	Processor 1 socket
12 A1 – A8	Memory modules A1 – A8
13 -	Video controller card connector
14 MEZZ1_FAB_C	Mezzanine card connector 1 Fabric C
15 MEZZ2_FAB_B	Mezzanine card connector 2 Fabric B
16 MEZZ3_FAB_C	Mezzanine card connector 3 Fabric C

# PowerEdge M710 System Board

Figure 7-5. PowerEdge M710 System Board Connectors

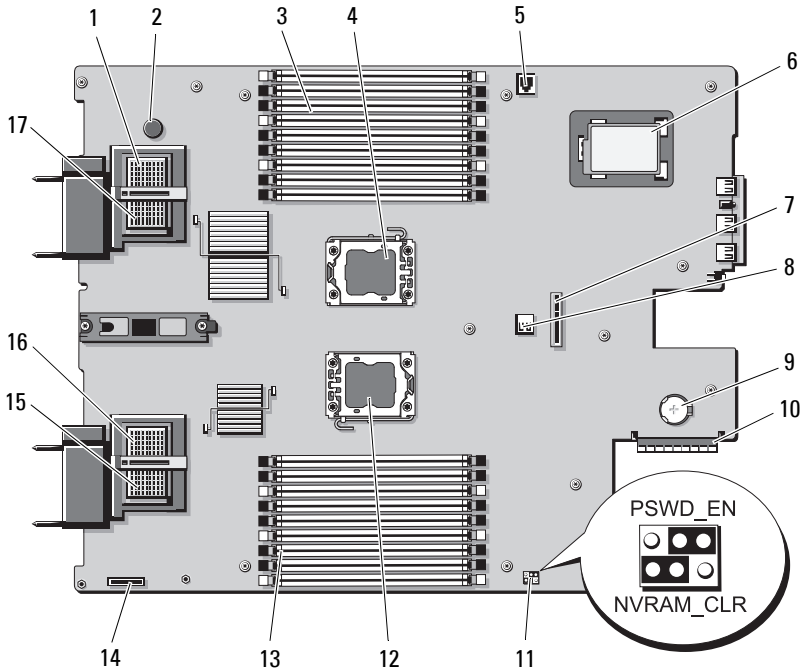


Table 7-13. PowerEdge M710 System Board Connectors

Connector	Description
1	MEZZ4_FAB_B Mezzanine card connector 4 Fabric B
2	- System board retention pin
3	B1 – B9 Memory modules B1 – B9
4	CPU2 Processor 2 socket
5	ISCSI_KEY Hardware key socket for integrated NIC feature
6	- Optional RAID battery
7	- Hard-drive backplane connector

**Table 7-13. PowerEdge M710 System Board Connectors (continued)**

Connector	Description
8 J_INT_USB	USB connector
9 -	Connector for the 3.0 V coin battery <b>NOTE:</b> Access requires removal of system board. See "Removing the System Board" on page 276.
10 J_STORAGE	Storage controller card connector
11 PWRD_EN, NVRAM_CLR	System configuration jumpers
12 CPU1	Processor 1 socket
13 A1 – A9	Memory modules A1 – A9
14 -	iDRAC6 Enterprise card connector
15 MEZZ1_FAB_C	Mezzanine card connector 1 Fabric C
16 MEZZ2_FAB_B	Mezzanine card connector 2 Fabric B
17 MEZZ3_FAB_C	Mezzanine card connector 3 Fabric C

# PowerEdge M710HD System Board

Figure 7-6. PowerEdge M710HD System Board Connectors

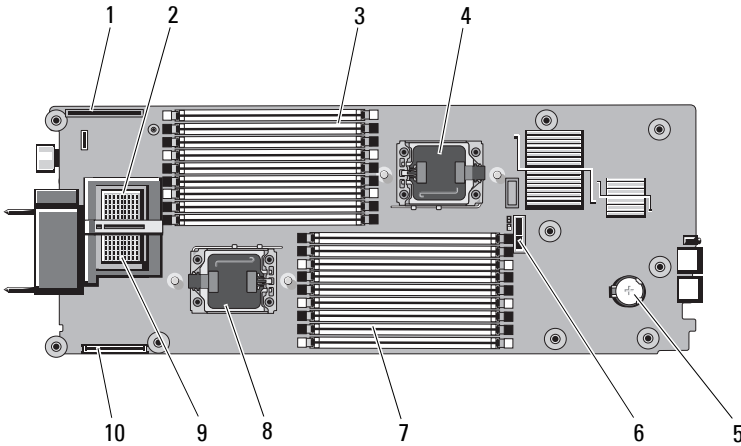


Table 7-14. PowerEdge M710HD System Board Connectors

Connector	Description
1 LOM RISER	Network Daughter Card/LOM Riser card connector
2 MEZZ2_FAB_B	Mezzanine card connector 2 Fabric B
3 A1 – A9	Memory modules A1 – A9
4 CPU2	Processor 2 socket
5 -	Connector for the 3.0 V coin battery <b>NOTE:</b> Access requires removal of system board. See "Removing the System Board" on page 276.
6 -	Hard-drive backplane connector
7 B1 – B9	Memory modules B1 – B9
8 CPU1	Processor 1 socket
9 MEZZ1_FAB_C	Mezzanine card connector1 Fabric C
10 MANAGEMENT RISER	Connector for internal dual SD module



# PowerEdge M610 System Board

Figure 7-7. PowerEdge M610 System Board Connectors

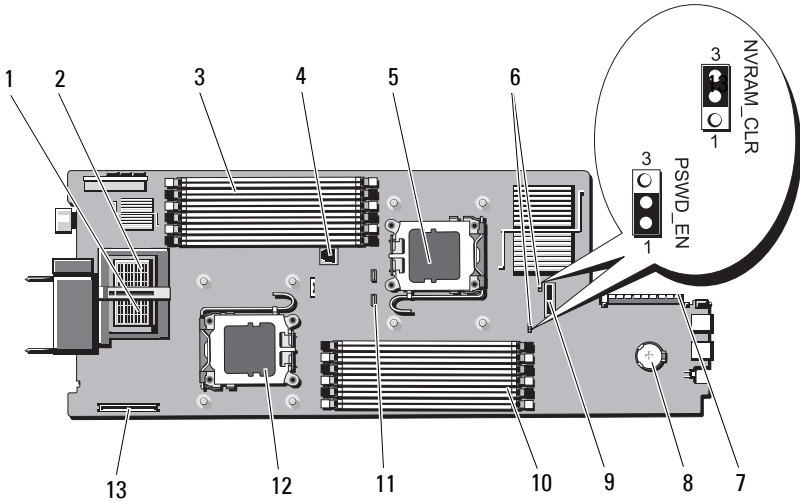


Table 7-15. PowerEdge M610 System Board Connectors

Connector	Description
1	MEZZ1_FAB_C Mezzanine card connector 1- Fabric C
2	MEZZ1_FAB_B Mezzanine card connector 2 - Fabric B
3	A1 – A6 Memory modules A1 – A6
4	- Hardware key socket for enabling the integrated NIC feature
5	CPU2 Processor 2 socket
6	PWRD_EN, NVRAM_CLR System configuration jumpers
7	- Storage controller card connector
8	BATTERY Connector for the 3.0 V coin battery

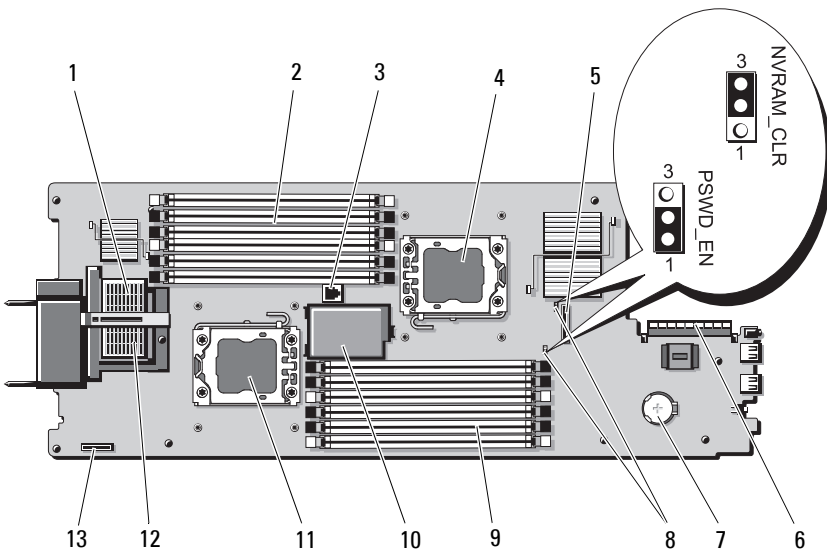
**NOTE:** Access requires removal of system board. See "Removing the System Board" on page 276.

**Table 7-15. PowerEdge M610 System Board Connectors (continued)**

Connector	Description
9 -	Hard-drive backplane connector
10 B1 – B6	Memory modules B1 – B6
11 -	RAID battery connector
12 CPU1	Processor 1 socket
13 -	iDRAC6 enterprise card connector

### PowerEdge M610x System Board

**Figure 7-8. PowerEdge M610x System Board Connectors**



**Table 7-16. PowerEdge M610x System Board Connectors**

Connector	Description
1 MEZZ2_FAB_B	Mezzanine interface card connector
2 A1 – A6	Memory modules A1 – A6
3 -	Hardware key socket for enabling the integrated NIC feature
4 CPU2	Processor 2 socket
5 -	Hard-drive backplane connector
6 -	Storage controller card connector
7 -	Connector for the 3.0 V coin battery
	<b>NOTE:</b> Access requires removal of system board. See "Removing the System Board" on page 276.
8 PWRD_EN, NVRAM_CLR	System configuration jumpers
9 B1 – B6	Memory modules B1 – B6
10 -	Optional RAID battery
11 CPU1	Processor 1 socket
12 MEZZ1_FAB_C	Mezzanine interface card connector
13 -	iDRAC6 enterprise card connector

## PowerEdge M610x Midplane Interface Card

Figure 7-9. PowerEdge M610x Midplane Interface Card Connectors

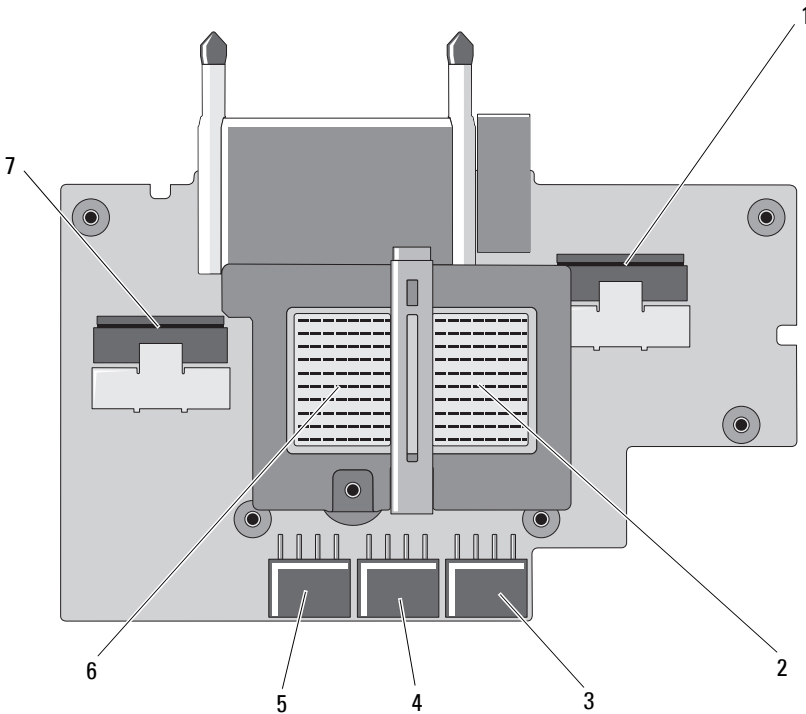


Table 7-17. PowerEdge M610x Midplane Interface Card Connectors

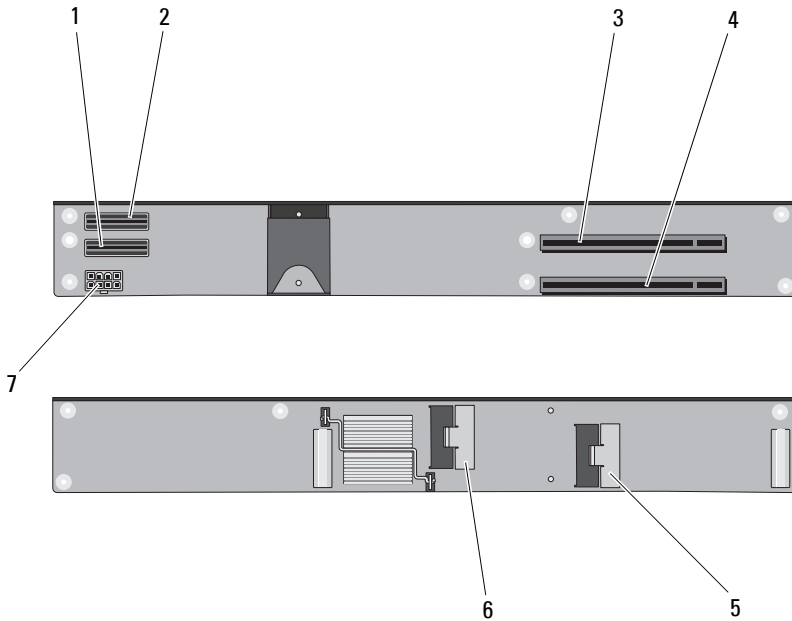
Connector	Description
1 Data 4	Data cable connector 4
2 MEZZ2_FAB_B1	Mezzanine card connector - Fabric B
3 PWR_CN3	Expansion card riser power connector
4 PCIe_PWR_CN5	PCIe card power connector
5 PCIe_PWR_CN4	PCIe card power connector

**Table 7-17. PowerEdge M610x Midplane Interface Card Connectors (continued)**

Connector	Description
6 MEZZ1_FAB_C1	Mezzanine card connector - Fabric C
7 Data 3	Data cable connector 3

## PowerEdge M610x Expansion-Card Riser

**Figure 7-10. PowerEdge M610x Expansion-Card Riser Connectors**

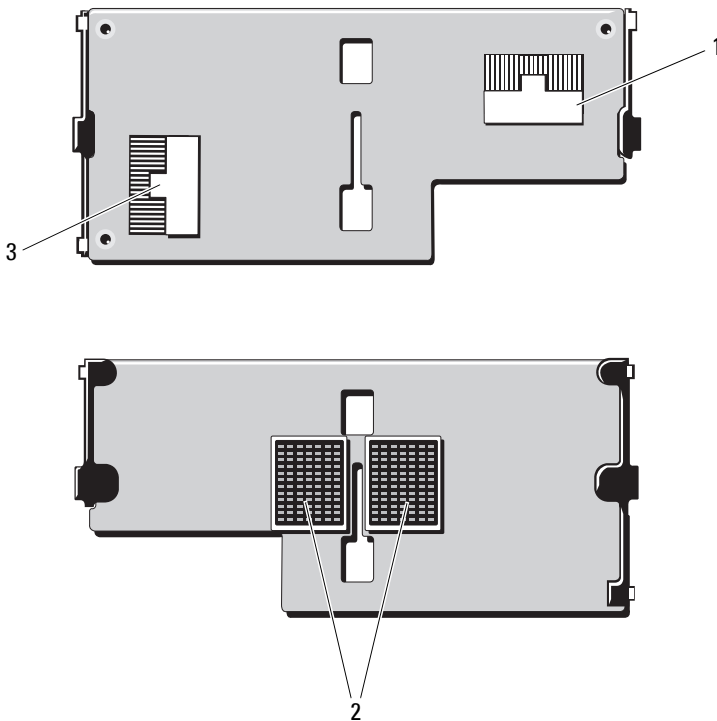


Connector	Description
1 Data 1	Data cable connector 1
2 Data 2	Data cable connector 2

Connector	Description	
3	PCIe 2	Expansion-card connector 2
4	PCIe 1	Expansion-card connector 1
5	Data 3	Data cable connector 3
6	Data 4	Data cable connector 4
7	-	Riser-card power connector

### PowerEdge M610x Mezzanine Interface Card

Figure 7-11. PowerEdge M610x Mezzanine Interface Card Connectors



Connector	Description
1 Data 2	Data cable connector 2
2 -	Mezzanine interface card connectors
3 Data 1	Data cable connector 1

## PowerEdge M605 System Board

Figure 7-12. PowerEdge M605 System Board Connectors

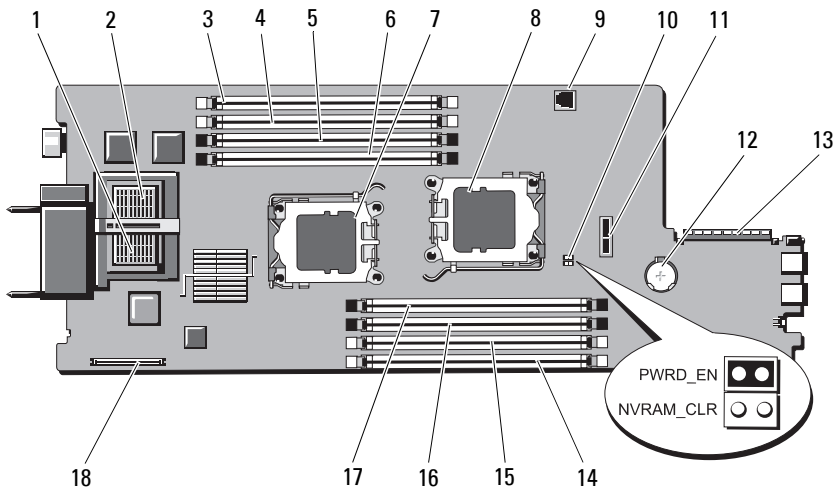


Table 7-18. PowerEdge M605 System Board Connectors

Connector	Description
1 -	Mezzanine card connector - Fabric C
2 -	Mezzanine card connector - Fabric B
3 A1	Memory module connector, slot A1
4 A2	Memory module connector, slot A2
5 A3	Memory module connector, slot A3
6 A4	Memory module connector, slot A4
7 CPU1	Processor 1 socket

**Table 7-18. PowerEdge M605 System Board Connectors (continued)**

<b>Connector</b>	<b>Description</b>
8 CPU2	Processor 2 socket
9 TOE_KEY	Hardware key socket for enabling the integrated NIC TOE/iSCSI feature
10 PWRD_EN, NVRAM_CLR	Configuration jumpers
11 SASBKPLN	Hard-drive backplane connector
12 BATTERY	Connector for the 3.0 V coin battery
13 J_STORAGE	Storage controller card connector
14 B1	Memory module connector, slot B1
15 B2	Memory module connector, slot B2
16 B3	Memory module connector, slot B3
17 B4	Memory module connector, slot B4
18 J_VIDEO	Video controller card connector



## PowerEdge M600 System Board

Figure 7-13. PowerEdge M600 System Board Connectors

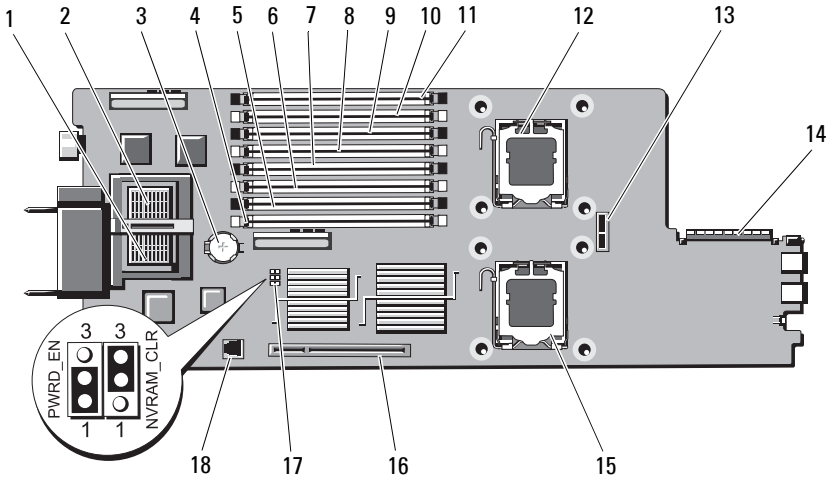


Table 7-19. PowerEdge M600 System Board Connectors


Connector	Description
1 -	Mezzanine card connector - Fabric C
2 -	Mezzanine card connector - Fabric B
3 BATTERY	Connector for the 3.0 V coin battery
4 1	Memory module connector, slot 1
5 5	Memory module connector, slot 5
6 2	Memory module connector, slot 2
7 6	Memory module connector, slot 6
8 3	Memory module connector, slot 3
9 7	Memory module connector, slot 7
10 4	Memory module connector, slot 4
11 8	Memory module connector, slot 8
12 CPU1	Processor 1 socket

**Table 7-19. PowerEdge M600 System Board Connectors (continued)**

Connector	Description
13 SASBKPLN	Hard-drive backplane connector
14 J_STORAGE	Storage controller card connector
15 CPU2	Processor 2 socket
16 J_VIDEO	video controller card connector
17 PWRD_EN, NVRAM_CLR	Configuration jumpers
18 TOE_KEY	Hardware key socket for enabling the integrated NIC TOE/iSCSI feature

## Disabling a Forgotten Password

The blade's software security features include a system password and a setup password, which are discussed in detail in "Using the System Setup Program and UEFI Boot Manager" on page 137. The password jumper enables these password features or disables them, and clears any password(s) currently in use.

 **CAUTION: Many repairs may only be done by a certified service technician. You should only perform troubleshooting and simple repairs as authorized in your product documentation, or as directed by the online or telephone service and support team. Damage due to servicing that is not authorized by Dell is not covered by your warranty. Read and follow the safety instructions that came with the product.**

- 1 Remove the blade. See "Removing a Blade" on page 155.
- 2 Open the blade. See "Opening the Blade" on page 159.
- 3 If you are changing the jumper setting on a PowerEdge M905 or M805 blade, remove the system board to gain access to the jumpers. See "Removing the System Board" on page 276.
- 4 Relocate the jumper plug to disable the password feature.  
See "System Board Connectors" on page 338 to locate the password jumper on the blade board.
- 5 If you are changing the jumper setting on a PowerEdge M905 or M805 blade, reinstall the system board. See "Installing the System Board" on page 280.

**6** Close the blade. See "Closing the Blade" on page 161.

**7** Install the blade. See "Installing a Blade" on page 158.

When the blade is on, the power-on indicator is solid green. Allow the blade to finish booting.

The existing passwords are not disabled (erased) until the system boots with the password removed. However, before you assign a new system and/or setup password, you must reinstall the password jumper.



**NOTE:** If you assign a new system and/or setup password with the jumper removed, the system disables the new password(s) the next time it boots.

**8** Remove the blade. See "Removing a Blade" on page 155.

**9** Open the blade. See "Opening the Blade" on page 159.

**10** If you are restoring the jumper setting on a PowerEdge M905 or M805 blade, remove the system board to gain access to the jumpers. See "Removing the System Board" on page 276.

**11** Relocate the jumper plug to enable the password feature.

**12** If you are restoring the jumper setting on a PowerEdge M905 or M805 blade, reinstall the system board. See "Installing the System Board" on page 280.

**13** Close the blade. See "Closing the Blade" on page 161.

**14** Install the blade. See "Installing a Blade" on page 158.

**15** Assign a new system and/or setup password. See "System and Setup Password Features" on page 151.



# Getting Help

## Contacting Dell

For customers in the United States, call 800-WWW-DELL (800-999-3355).



**NOTE:** If you do not have an active Internet connection, you can find contact information on your purchase invoice, packing slip, bill, or Dell product catalog.

Dell provides several online and telephone-based support and service options. Availability varies by country and product, and some services may not be available in your area. To contact Dell for sales, technical support, or customer service issues:

- 1 Visit [support.dell.com](http://support.dell.com).
- 2 Click your country/region at the bottom of the page. For a full listing of country/region, click **All**.
- 3 Click **All Support Options** from the **Support** menu.
- 4 Select the appropriate service or support link based on your need.
- 5 Choose the method of contacting Dell that is convenient for you.



# Index

## A

AC power present indicator, 37

## B

batteries

troubleshooting, 324

battery, 265

installing, 265

removing, 265

blade board

troubleshooting, 323

blade power button, 30

blades

closing, 161

installing, 158

opening, 159

processors, 243

removing, 155

boot drive

configuring, 269

## C

checking equipment, 310

closing

blades, 161

CMC module, 48, 293

fault indicator, 49

installing, 295-296

link activity indicator, 49

link indicator, 49

removing, 293, 296

status indicator, 49

troubleshooting, 315

configuring

boot drive, 269

connectors

system board, 338

contacting Dell, 361

## D

Dell

contacting, 361

diagnostics

advanced testing options, 329

error messages, 329

see *system diagnostics* and *Server*

*Administrator diagnostics*

testing options, 328

drive carrier

hard drive, 270

## E

error messages, 138

- expansion cards
  - installing, 236
  - removing, 238
- expansion slots, 235
- expansion-card riser, 239

## F

- fan module indicators, 37
- fans
  - installing, 292
  - removing, 291
  - troubleshooting, 315
- features
  - back-panel, 34
  - blade, 22
  - blade power button, 30
  - CMC module, 48
  - Fibre Channel pass-through module, 88, 92
  - Fibre Channel switch module, 96, 98-100
  - Gb Ethernet pass-through module, 101
  - hard drive, 31
  - I/O connectivity, 52
  - PowerConnect Ethernet switch, 74-75, 83
  - system, 14
- Fibre Channel pass-through module, 88, 92
- Fibre Channel switch module, 96, 98-100

## G

- Gb Ethernet pass-through module, 101
- getting help, 361
- guidelines
  - expansion card installation, 235
  - memory installation, 173, 179, 182, 185, 190, 195, 200, 205

## H

- hard drive
  - installing in a drive carrier, 270
  - removing from a drive carrier, 269
- hard drives, 267
  - features, 31
  - installing, 267
  - removing, 269
  - troubleshooting, 320
- hard-drive backplane
  - installing, 274
  - removing, 274
- help
  - getting, 361

## I

- I/O bays
  - populating, 52
- I/O module
  - installing, 298
  - removing, 296



- identifying
  - midplane version, 38
- iKVM module, 296
  - features, 41
  - installing, 296
  - removing, 296
  - tiering, 44
- indicators
  - AC power present, 37
  - CMC fault, 49
  - CMC link, 49
  - CMC link activity, 49
  - CMC status, 49
  - fan module, 37
  - Fibre Channel pass-through module, 75-76, 94, 100
  - power supply, 36
  - power supply fault, 37-38
  - server module power selection, 30
  - system power, 17
- installing
  - battery, 265
  - blades, 158
  - CMC module, 295-296
  - expansion card, 236
  - fans, 292
  - hard drive in a drive carrier, 270
  - hard drives, 267
  - I/O module, 298
  - memory, 213
  - memory guidelines, 173, 182, 185, 205
  - mezzanine card, 217
  - power supplies, 291
- integrated network card, 233

## **K**

- keyboards
  - troubleshooting, 311
- keystrokes
  - system setup program, 138

## **L**

- LOM riser card, 233

## **M**

- memory
  - installing, 213
  - troubleshooting, 319
- memory modules
  - removing, 214
- memory modules (DIMMs)
  - configuring, 179, 190, 195, 200
- messages
  - alert, 135
  - blade, 115
  - error messages, 138
  - status LCD, 103
  - system diagnostics, 135
  - systems management, 312
  - warning, 115
- mezzanine card
  - installing, 217
- mezzanine interface card, 215
- mini planar, 283
- mouse

troubleshooting, 311

## **N**

network switch module  
troubleshooting, 318

NVRAM backup, 265

## **O**

opening  
blades, 159

options  
system setup, 139

## **P**

password  
disabling, 358  
setup, 153  
system, 151

password features  
setup, 151  
system, 151

phone numbers  
obtaining, 361

POST  
accessing system features, 13

power supplies  
installing, 291  
removing, 288  
troubleshooting, 314

PowerConnect Ethernet switch  
module, 74-75, 83

processors  
blades, 243  
troubleshooting, 322

## **R**

recommended tools, 155

removing  
battery, 265  
blade blank, 158  
blades, 155  
CMC module, 293, 296  
expansion card, 238  
fans, 291  
hard drive, 269  
hard drive from a drive carrier, 269  
I/O module, 296  
memory, 214  
power supplies, 288

## **S**

safety, 309

securing your system, 147, 152

server module components  
troubleshooting, 319

setup password, 153

setup password features, 151

slots  
*See* expansion slots.

- start-up
  - accessing system features, 13
- support
  - contacting Dell, 361
- system board
  - connectors, 338
- system control panel, 16
- system fans, 291
- system features, 14
  - accessing, 13
- system password, 151
- system password features, 151
- system power button, 17
- system power indicator, 17
- system setup
  - options, 139
  - using, 138
- system setup program
  - entering, 138
  - SATA settings, 143
  - serial communications
    - options, 146
  - system security options, 147
- system setup screens
  - console redirection, 146
  - integrated devices, 144
  - system security, 148

## **T**

- technical assistance
  - obtaining, 361

- telephone numbers
  - obtaining, 361
- TPM security, 147
- troubleshooting
  - battery, 324
  - blade board, 323
  - CMC module, 315
  - external connections, 310
  - fans, 315
  - hard drive, 320
  - keyboard, 311
  - memory, 319
  - mouse, 311
  - network switch module, 318
  - power supplies, 314
  - processors, 322
  - server module components, 319
  - start-up routine, 309
  - USB devices, 312

## **U**

- UEFI Boot Manager
  - entering, 150
  - main screen, 150
  - System Utilities screen, 151
  - UEFI Boot Settings screen, 150
- USB
  - devices, troubleshooting, 312
  - using system setup, 138

## **V**

video controller  
installing, 273